

390-G

AC POWER SOURCE

**OPERATION
MANUAL**



CERTIFICATION

PACIFIC POWER SOURCE CERTIFIES THAT THIS INSTRUMENT WAS THOROUGHLY TESTED AND INSPECTED AND FOUND TO MEET OR EXCEED ITS PUBLISHED SPECIFICATIONS WHEN IT WAS SHIPPED FROM THE FACTORY.

LIMITED WARRANTY

Pacific Power Source (PPS) warrants each unit to be free from defects in material and workmanship. For the period of two (2) years from the date of shipment to the purchaser, PPS will either repair or replace, at its sole discretion, any unit returned to its factory in Irvine, California. This warranty does not cover batteries. It does not cover damage arising from misuse of the unit or attempted field modifications or repairs. This warranty specifically excludes damage to other equipment connected to this unit.

Upon notice from the purchaser within (30) days of shipment of units found to be defective in material or workmanship, PPS will pay all shipping charges for the repair or replacement. If notice is received more than thirty (30) days from shipment, all shipping charges shall be paid by the purchaser. Units returned on debit memos will not be accepted and will be returned without repair.

This warranty is exclusive of all other warranties, express or implied.

G/GR-SERIES AC POWER SOURCE
OPERATIONS AND SERVICE MANUAL

THIS MANUAL IS ASSIGNED TO

SYSTEM S/N _____

THE INFORMATION CONTAINED
IN THIS MANUAL IS PROPRIETARY TO
PACIFIC POWER SOURCE, INC.
MAY NOT BE COPIED OR REPRINTED
WITHOUT ITS EXPRESSED WRITTEN CONSENT.

PACIFIC POWER SOURCE, INC.
17692 FITCH
IRVINE, CALIFORNIA 92614

PACIFIC PART NO. 114250-F

SECTION 1
GENERAL DESCRIPTION
TABLE OF CONTENTS

Para.	Title	Page
1.0	General Description	1-1
1.1	System	1-1
1.2	Mainframe	1-1
1.3	Power Module	1-1
1.4	Control Module	1-1
1.5	Paralleled Systems	1-3
1.6	Model Numbering System	1-3

LIST OF ILLUSTRATIONS

Fig.	Title	Page
1-1	Model 390-G Module Location Detail	1-2

SECTION 2
ELECTRICAL SPECIFICATIONS
TABLE OF CONTENTS

Para.	Title	Page
2.0	Electrical Specifications	2-1
2.1	Input Power	2-1
2.2	Output Power	2-3

LIST OF ILLUSTRATIONS

Fig.	Title	Page
2-1	Input Power Form Table	2-2
2-2	Output Power Derating Curves	2-4

SECTION 3
MECHANICAL SPECIFICATIONS
TABLE OF CONTENTS

Para.	Title	Page
3.0	Mechanical Specifications	3-1
3.1	Dimensions	3-1
3.2	Weight	3-1
3.3	Airflow and Cooling	3-3

LIST OF ILLUSTRATIONS

Fig.	Title	Page
3-1	390-G Outline Drawing	3-2
3-2	Airflow Detail	3-4

SECTION 4
INSTALLATION
TABLE OF CONTENTS

Para.	Title	Page
4.0	Installation	4-1
4.1	Crating, Uncrating and Moving	4-3
4.2	Clearances	4-3
4.3	Floor Loading	4-3
4.4	Input Power Connection	4-5
4.5	Output Power Connection	4-7

LIST OF ILLUSTRATIONS

Fig.	Title	Page
4-1	Crating Detail	4-2
4-2	Input/Output Terminal Location	4-6

SECTION 5

OPERATION

TABLE OF CONTENTS

Para.	Title	Page
5.0	Operation	5-1
5.1	First Time Operation	5-1
5.2	Input Power - Verification of Correct Input Voltage	5-1
5.3	Power Module - Verification of Normal Operation	5-1
5.4	Control Module - Recommended Operating Sequence	5-3
5.5	Output Power - Applying the Load	5-7
5.6	Multi-cabinet Operation	5-9
5.6.1	Installation of Multi-cabinet PLC	5-11
5.6.2	Installation of Multi-cabinet UPS	5-15
5.7	Maintenance	5-17
5.8	Calibration	5-17
5.9	General Repair Procedure	5-17

LIST OF ILLUSTRATIONS

Fig.	Title	Page
5-1	Model 390-GC Front View	5-2
5-2	Control Module Controls Detail	5-4
5-1	Output Power Terminals Detail	5-8
5-4	Multi-cabinet System Wiring Diagram	5-10
5-1	Model 390-G Filter Location & Removal	5-18

SECTION 6
MAINFRAME DETAILED DESCRIPTION

TABLE OF CONTENTS

Para.	Title	Page
6.0	Mainframe Detailed Description	6-1
6.1	Description	6-1
6.2	Theory of Operation	6-7
6.3	Input Power Form Configuration	6-9
6.4	Calibration	6-22
6.5	Service	6-22

LIST OF ILLUSTRATIONS

Fig.	Title	Page
6-1	Model 390-G Assy. Dwg.	6-2
6-2(a)	Power Supply Assy. Dwg. (Sht. 1)	6-3
6-2(b)	Power Supply Assy. Dwg. (Sht. 2)	6-4
6-3	Model 390-G Mainframe Schematic	6-5
6-4	Input Transformer Schematic	6-10
6-5	Input Power Form Table	6-12
6-6	LCU Operating Points	6-14
6-7(a)	Input Power Forms Wiring Diagrams (Forms: AL, AN, AH)	6-16
6-7(b)	Input Power Forms Wiring Diagrams (Forms: CL, CN, CH)	6-17
6-7(c)	Input Power Forms Wiring Diagrams (Forms: DL, DN, DH)	6-18
6-7(d)	Input Power Forms Wiring Diagrams (Forms: EL, EN, EH)	6-19
6-7(e)	Input Power Forms Wiring Diagrams (Forms: FL, FN, FH)	6-20
6-7(f)	Input Power Forms Wiring Diagrams (Forms: GL, GN, GH)	6-21

SECTION 7
MODEL 120-GO
DETAILED DESCRIPTION

TABLE OF CONTENTS

Para.	Title	Page
7.0	Model 120-GO Detailed Description	7-1
7.1	Description	7-1
7.1.1	Model 120-GO Chassis Assy Material List	7-3
7.1.2	Model 120-GO Power Amplifier Assy Material List	7-7
7.2	Theory of Operation	7-9
7.3	Servicing	7-11
7.3.1	Safety Notices	7-11
7.3.2	Locating a Faulty Module	7-12
7.3.3	Removing the Module from the System	7-12
7.3.4	Installing the Module Into the System	7-13
7.3.5	Field Service of the Module	7-14
7.4	Calibration	7-15

LIST OF ILLUSTRATIONS

Fig.	Title	Page
7-1	Model 120-GO Chassis Assy. Drawing	7-4
7-2	Model 120-GO Power Amplifier Assy. Drawing	7-5
7-3	Model 120-GO Power Amplifier Schematic	7-6
7-4	Model 120-GO Power Amplifier Block Diagram	7-10

SECTION 8

CONTROL MODULE DETAILED DESCRIPTION

TABLE OF CONTENTS

Para.	Title	Page
8.0	Control Module Detailed Description	8-1
8.1	Description	8-1
8.1.1	Control Module Chassis Material List	8-1
8.1.2	Voltage Amplifier Assembly Material List	8-4
8.1.3	Model 301-C Front Panel/Oscillator Material List	8-7
8.1.4	Model 301-H Front Panel/Oscillator Material List	8-11
8.1.5	Oscillator PCB Material List	8-15
8.2	Theory of Operation	8-18
8.3	Service	8-19
8.4	Calibration	8-21

LIST OF ILLUSTRATIONS

Fig.	Title	Page
8-1	Control Module Chassis Ass'y Dwg.	8-2
8-2	Control Module Chassis Schematic	8-3
8-3	Voltage Amplifier Ass'y Dwg.	8-5
8-4	Voltage Amplifier Schematic	8-6
8-5	301-C Front Panel Ass'y Dwg.	8-8
8-6	301-C Oscillator Schematic	8-9
8-7	301-H Front Panel Ass'y Dwg.	8-12
8-8	301-H Oscillator Schematic	8-13
8-9	Oscillator Card Ass'y Dwg.	8-16
8-10	System Block Diagram	8-17

SECTION 9

TRANSFORMER OUTPUTS and MODIFICATIONS

TABLE OF CONTENTS

Para.	Title	Page
9.1	Transformer Outputs	9-1
9.2	Modifications	9-3

- THIS PAGE INTENTIONALLY LEFT BLANK -

SECTION 1
GENERAL DESCRIPTION
TABLE OF CONTENTS

Para.	Title	Page
1.0	General Description	1-1
1.1	System	1-1
1.2	Mainframe	1-1
1.3	Power Module	1-1
1.4	Control Module	1-1
1.5	Paralleled Systems	1-3
1.6	Model Numbering System	1-3

LIST OF ILLUSTRATIONS

Fig.	Title	Page
1-1	Model 390-G Module Location Detail	1-2

1.0 GENERAL DESCRIPTION

1.1 SYSTEM

The 390-GC or 390-GH is a precision solid state AC-AC power converter. It is modular in design for easy use and flexibility. Each 390-GC or 390-GH consists of a mainframe, a control module and 9 power modules. (See Figure 1-1).

The 390-GC will produce isolated 18 KVA AC power as a stand alone system at any frequency in the power spectrum, single or three phase. The 390-GH will produce an isolated 18KVA of AC power as a stand alone system at only one customer specified frequency in the power spectrum, single or three phase. Output voltages are nominally 0 - 120 Volts, but output transformers may be added for various output voltages.

1.2 MAINFRAME

The 390-G mainframe contains the input transformer, the power supply and provisions for rack mounting of the control module and up to 9 power modules.

1.3 POWER MODULE

The 120-GO Power Module is a 2KVA power amplifier with direct coupled output. This provides fast transient response and excellent regulation. This module also has instantaneous current limiting to protect the module and patented fail-safe features which allow shorted output devices to clear themselves without loss of output.

1.4 CONTROL MODULE

The 301-C Control Module provides all the control functions for the system. It provides an oscillator with frequency and amplitude adjustments, voltage amplifiers, output contactor control and output voltage metering.

The 301-H control module provides all the control functions for the system. It provides a fixed frequency oscillator with amplitude adjustments, voltage amplifiers and output voltage metering.

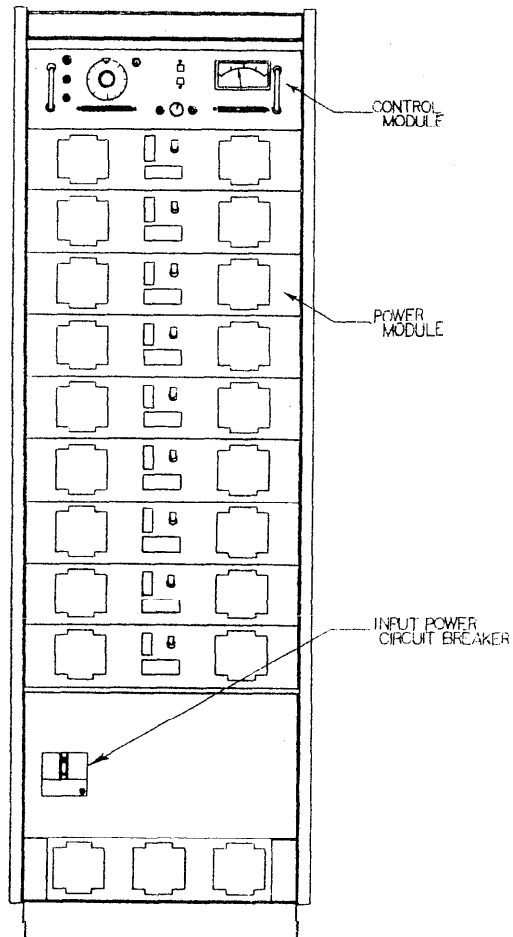

FIGURE 1-1
MODEL 390-G
MODULE LOCATION DETAIL

1-2

1.5 PARALLELED SYSTEMS

Up to five 390-G mainframes may be paralleled in the three phase mode for up to 90 KVA of three phase power, or three mainframes in the single phase mode for up to 54 KVA of single phase power. Only one control module is required in a multi-cabinet system.

1.6 MODEL NUMBERING SYSTEM

The model number describes the mainframe size, class of equipment, type of control module used, if it has output transformers and ,if any, customer specified modifications.

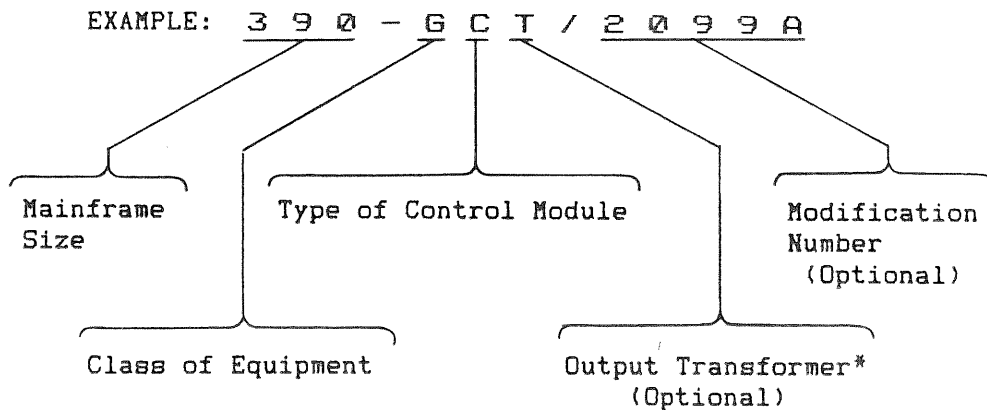

* The transformer part number must be included elsewhere to determine the type of output transformer.

Pacific's G-Series power sources are also provided at power levels of 6KVA and 12KVA. The Model 330-G Series are rated at 6KVA of output power while the 12KVA model is numbered as the Model 360-G Series.

All G-Series power sources use the 120-G0 Power Module and either the 301-C or the 301-H Control Module. This allows for economical sparing of modules in cases where several G-Series power sources are maintained.

SECTION 2
ELECTRICAL SPECIFICATIONS

TABLE OF CONTENTS

Para.	Title	Page
2.0	Electrical Specifications	2-1
2.1	Input Power	2-1
2.2	Output Power	2-3

LIST OF ILLUSTRATIONS

Fig.	Title	Page
2-1	Input Power Form Table	2-2
2-2	Output Power Derating Curves	2-4

2.0 ELECTRICAL SPECIFICATIONS

2.1 INPUT POWER

The 390-G will require up to 28 KVA of input power, either three phase DELTA or three phase WYE. The unit presents a DELTA load to the input power but may be connected to a WYE input with no neutral connection. The 390-G will operate with an input phase rotation of either ABC or BAC.

The input transformer has a universal input winding that allows any of the input forms listed on figure 2-1. Other forms are available as options. Refer to Section 6.3 for information regarding input configurations of the various input forms.

The unit draws very little input current at no-load. Input current will vary proportionally with output load current. Input power at full load is approximately 28 KVA. Slightly larger input service is recommended to prevent nuisance trips of external circuit breakers.

- - - C A U T I O N - - -

DO NOT APPLY EXCESSIVE
INPUT VOLTAGE OR MACHINE
DAMAGE WILL RESULT

- - - - -

INPUT FORM	INPUT VOLTS	INPUT FREQ. (HZ)	INPUT SERVICE RECOMMENDED
A	240 VL-L RMS 3 PHASE DELTA	47-63	90 AMPS/PHASE
C	120/208 VRMS 3 PHASE WYE	47-63	100 AMPS/PHASE
D	480 VL-L RMS 3 PHASE DELTA or 277/480 VRMS 3 PHASE WYE	47-63	45 AMPS/PHASE

NOTE:

400 Hz Input Frequency Option available for all input forms listed above.

FIGURE 2-1

MODEL 390-G
INPUT POWER FORM TABLE

2.2 OUTPUT POWER

Output Voltage Range:	0-120 VAC 1 Phase or 0-120/208 VAC 3 Phase.
Output Current:	144 AMPS RMS 1 Phase or 48 AMPS RMS per Phase, 3 Phase mode; 432 AMPS PEAK 1 Phase or 144 AMPS PEAK per Phase, 3 Phase mode is available at crest of sinewave for driving peak type loads such as DC power supplies.
Power Factor:	+0.7 full power output; (see figure 2-2).
Line Regulation:	0.1% Maximum
Output Distortion:	0.75% THD, Maximum
Output Modulation:	0.25% Maximum
Isolation:	Floating output, any one output terminal may be grounded to chassis.
Output Protection:	Instantaneous current limiting. Automatic recovery upon removal of overload.
Oscillator Frequency:	47-500 Hz Variable, 50, 60, 400 Hz Fixed $\pm 0.25\%$.
Bandwidth:	Full power output: 47-1000 Hz. Small signal bandwidth: 20-20,000 Hz.
Response Time:	50 microseconds, Maximum.
DC Offset:	10 mVDC, Maximum.

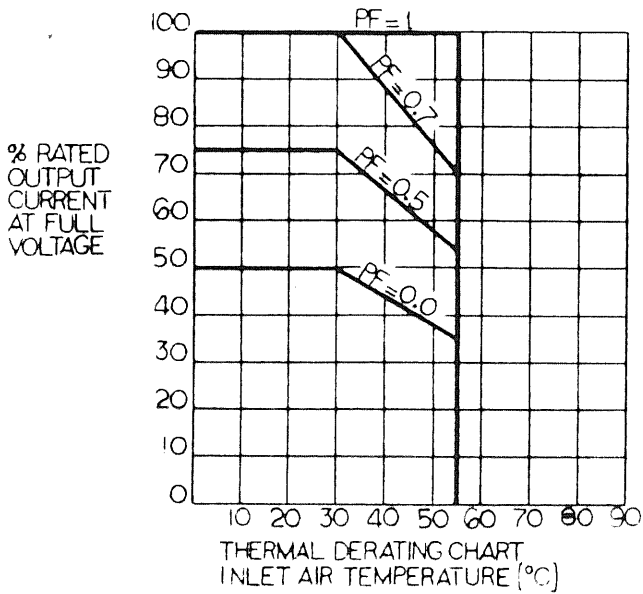

TYPICAL SUSTAINED OUTPUT VOLTAGE VS INPUT POWER INTERRUPTION, MULTIPLY CURRENT BY 3 FOR 1Ø MACHINE

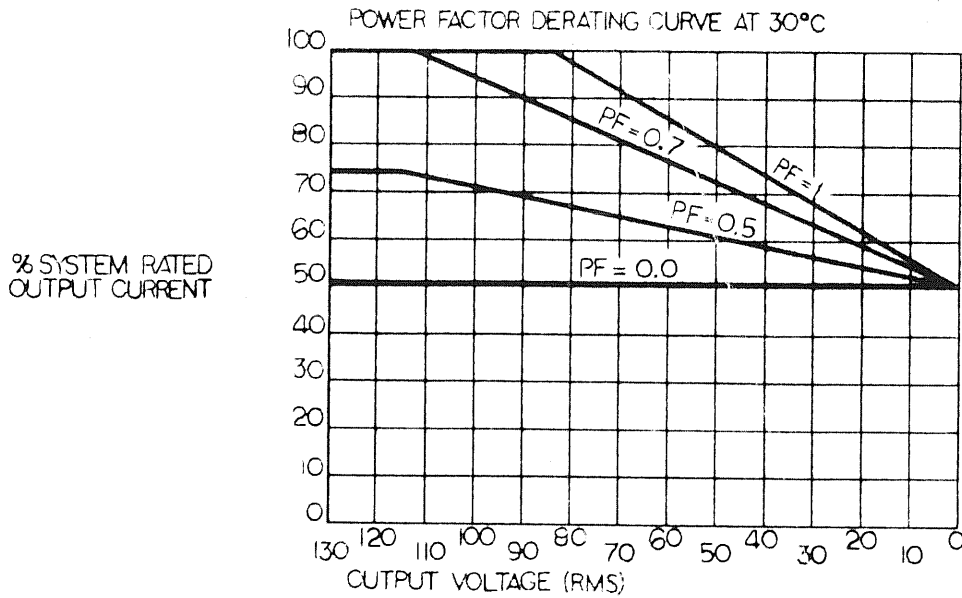
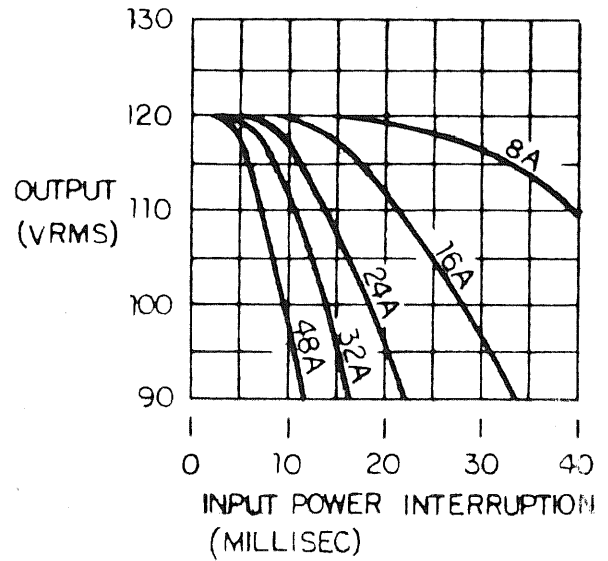

FIGURE 2-2

MODEL 390-G
OUTPUT DERATING CURVES

2.2 OUTPUT POWER (con't)

Metering:

Output Voltage:

4 1/2" analog meter movement measures VL-N and VL-L on primary output only. Phase Selection via a 6-position pushbutton switch array.

Current:

Module ammeter located in each power module, measures current produced by each module.

Input Voltage:

Measures input voltage and displays voltage in terms of percentage. Color coded scale provides a convenient reference point to verify optimum system performance.

Temperature:

0 - 55 Degrees C, ambient.

Load Regulation:

0-120 VAC Range = 0.25% maximum into any load P.F., at sense point. In three phase systems, unbalanced loads do not affect regulation.

Specifications subject to change without notice.

SECTION 3
MECHANICAL SPECIFICATIONS

TABLE OF CONTENTS

Para.	Title	Page
3.0	Mechanical Specifications	3-1
3.1	Dimensions	3-1
3.2	Weight	3-1
3.3	Airflow and Cooling	3-3

LIST OF ILLUSTRATIONS

Fig.	Title	Page
3-1	390-G Outline Drawing	3-2
3-2	Airflow Detail	3-4

3.0 MECHANICAL SPECIFICATIONS

3.1 DIMENSIONS

Figure 3-1 shows an outline drawing of a 390-G system. The casters may be removed and a fork lift base added. The fork lift base will add 0.4 inches to the overall height.

The 301-C and 301-H Control Module are 19-inch wide rack mount units, 7 inches high and 21 inches deep.

The 120-GO Power Module is a 19-inch wide rack mount unit, 5 1/4 inches high and 19 inches deep.

3.2 WEIGHT

The weight of a 390-G system is approximately 1000 pounds. Systems which utilize output transformers weigh approximately 1300 pounds.

The weight of the 301-C or 301-H Control Module is 25 pounds.

The weight of a 120-GO Power Module is 30 pounds.

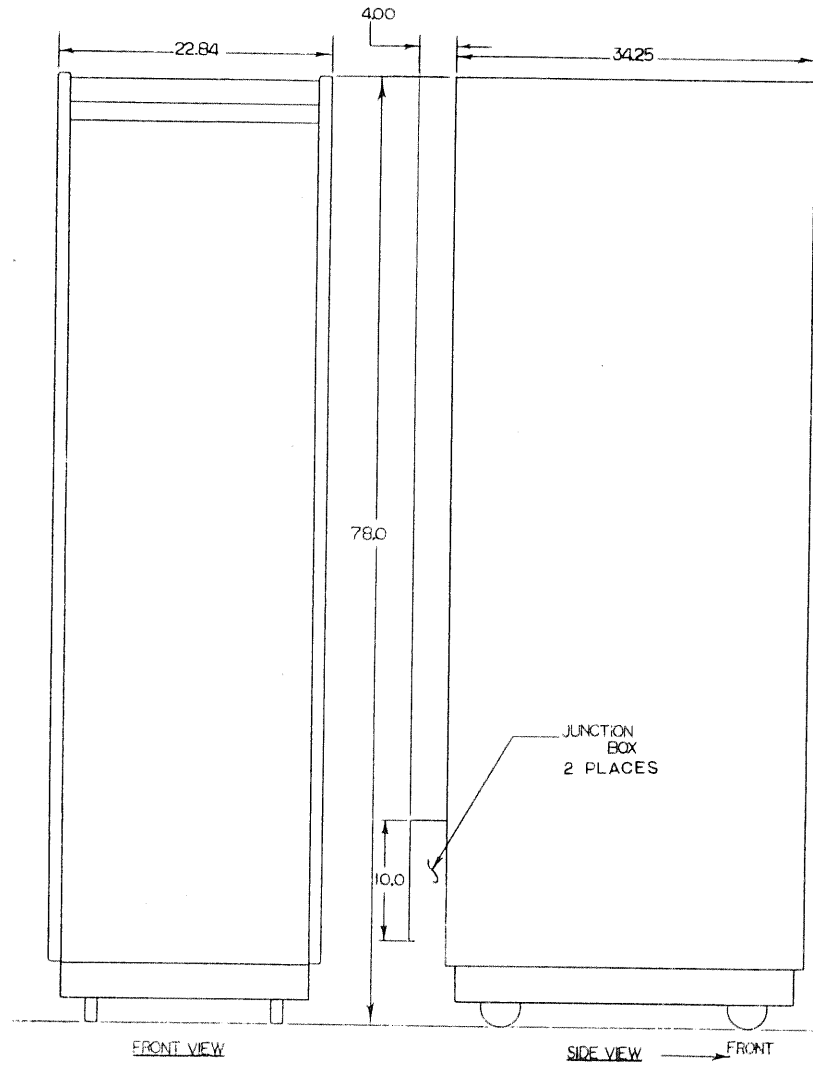

FIGURE 3-1

MODEL 390-G
OUTLINE DRAWING

3-2

3.3 AIRFLOW and COOLING

The amount of heat dissipated by the 390-G system is dependent upon the output load attached to it. When typical electronic loads such as EDP equipment, avionics, instrumentation, etc. are connected, the user can expect the system to dissipate approximately 800 BTU/Hr per KVA of output. In cases where the load is linear and of a poor power factor, the system may dissipate as much as 48,000 BTU/hr.

The cooling fans of the 390-G will draw in approximately 2000 CFM of air. The air enters in the front, through the filter door, and exhausts out the rear. (See figure 3-2). When located in small rooms, at least 2000 CFM of room ventilation is recommended.

CONVERSION FACTORS:

- 1 Ton A/C = 12,000 BTU/Hr
- 1 KW = 3,412 BTU/Hr

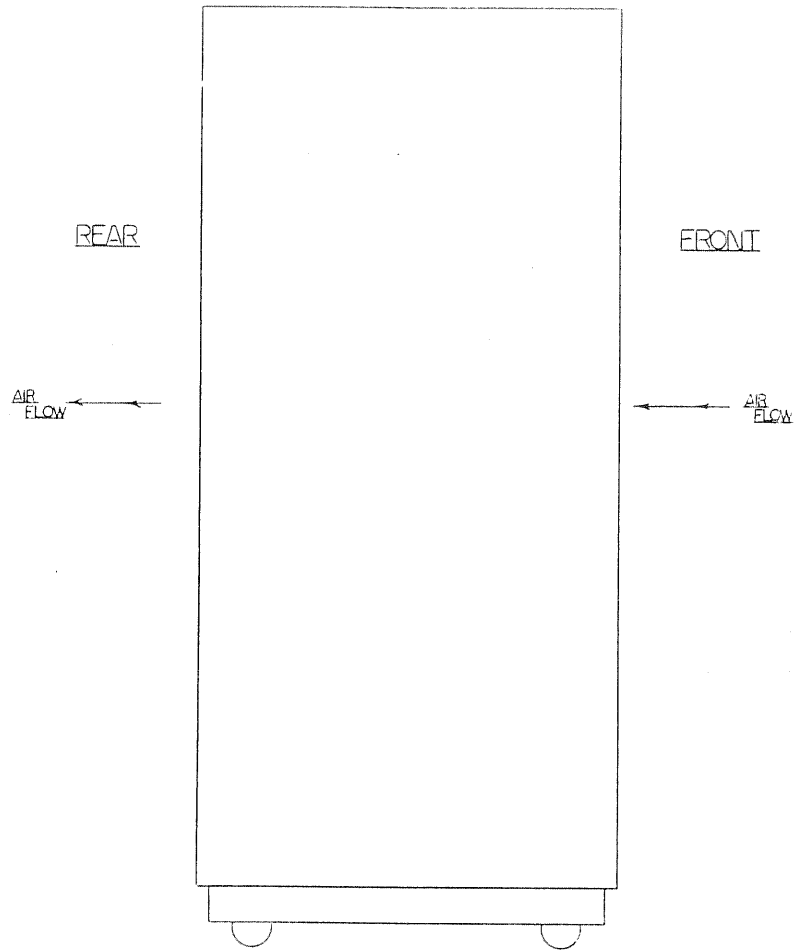

FIGURE 3-2

MODEL 390-G
AIRFLOW DETAIL

3-4

- THIS PAGE INTENTIONALLY LEFT BLANK -

SECTION 4
INSTALLATION
TABLE OF CONTENTS

Para.	Title	Page
4.0	Installation	4-1
4.1	Crating, Uncrating and Moving	4-3
4.2	Clearances	4-3
4.3	Floor Loading	4-3
4.4	Input Power Connection	4-5
4.5	Output Power Connection	4-7

LIST OF ILLUSTRATIONS

Fig.	Title	Page
4-1	Crating Detail	4-2
4-2	Input/Output Terminal Location	4-6

4.0 INSTALLATION

4.1 CRATING, UNCRATING and MOVING

Crating Notice:

It is the customer's responsibility to insure that cabinets are adequately crated when they are sent to a different site or returned for repair. Heavy wooden crates with fork lift bases and shock absorbing material under the base and on all sides to reduce shock and vibration are recommended. The crate should be securely fastened or banded together. Units are to be crated, shipped and handled in the vertical position only.

- - - C A U T I O N - - -

* DO NOT PERMIT SHIPMENT OF UNITS ON THEIR SIDE.
STRUCTURAL DAMAGE MAY RESULT.

* THE MANUFACTURER'S WARRANTY IS VOID FOR UNITS
IMPROPERLY CRATED OR SHIPPED ON ANY OF THE FOUR SIDE
SURFACES OR UPSIDE DOWN.

- - - - -

Uncrating:

Pacific "G" Series power sources are shipped in wooden crates with a shock absorbing padding on all sides. While crated, they can be moved with a fork lift or hand truck. Uncrating instructions are attached to the outside of the crate and should be adhered to.

Moving:

Standard cabinets are equipped with casters for portability. These casters are intended for rolling in a local area over relatively smooth floors; they are not designed to traverse steps, rough surfaces, etc. The decorative shroud around the base limits ground clearance and the cabinets will not pass over ridges or depressions. If it is necessary to pass over carpeted flooring, sheets of plywood over the rugs will aid in moving.

If the cabinet is to be moved outside of the building or on rough surfaces, it is recommended that the cabinet be securely strapped to a forklift base and that a forklift or a handtruck be used to move the cabinet. The center of gravity is about 18" from the bottom, which aids stability, however, these cabinets are tall and heavy and the possibility of capsizing exists. They should be moved carefully.

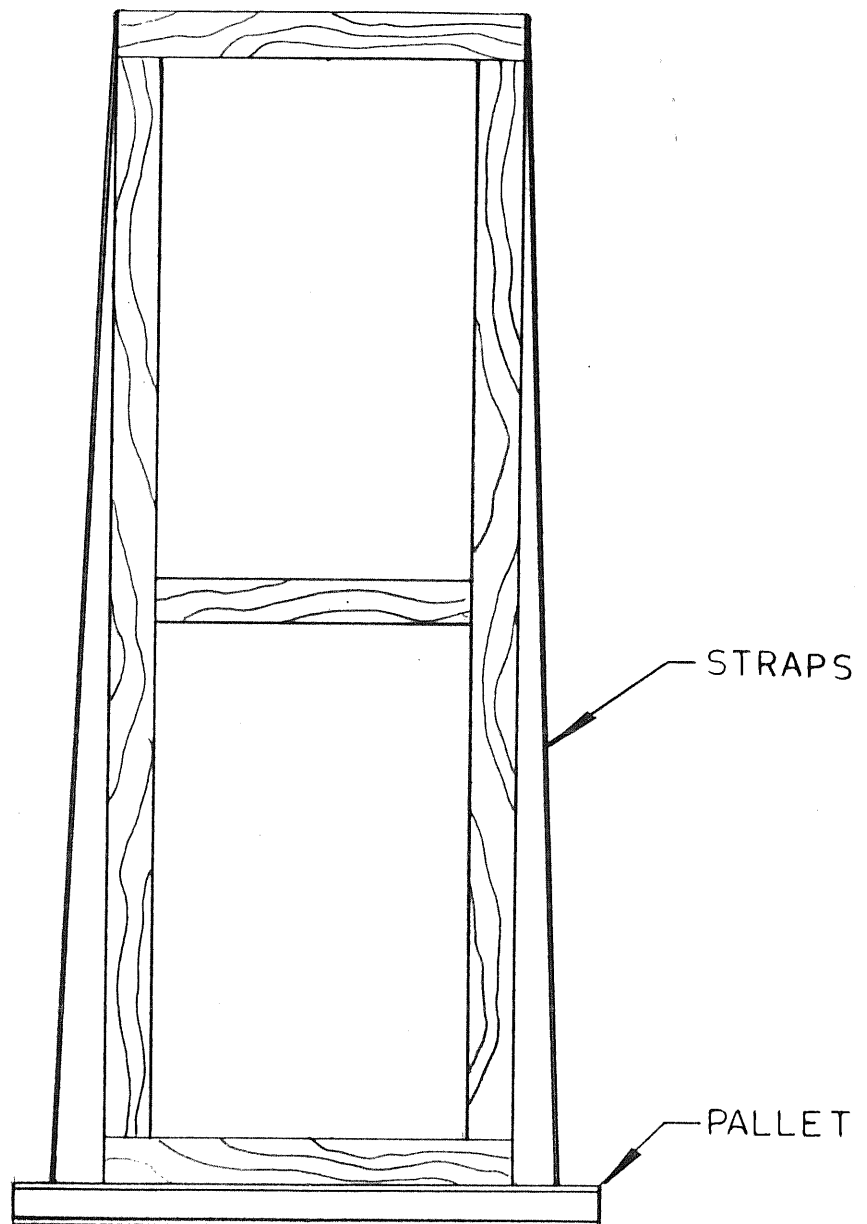

FIGURE 4-1

MODEL 390-G
CRATING DETAIL

4-2

4.2 CLEARANCES

The equipment should be given at least 2 feet clearance front and rear for air flow and access to equipment. The cabinets do not require any clearance on the sides.

All modules are removable from the front with the door open.

4.3 FLOOR LOADING

The standard base is a caster base which allows freedom of movement. The caster base is not recommended for use on soft floors because the unit load per square inch can become excessive. For use on other than concrete floors, it is recommended that the fork lift base be used to reduce the unit load per square inch.

- THIS PAGE INTENTIONALLY LEFT BLANK -

4.4 INPUT POWER CONNECTION

* * * W A R N I N G * * *

LETHAL VOLTAGES ARE PRESENT AT THE INPUT OF THIS MACHINE.
REFER INPUT CONNECTION TO A QUALIFIED ELECTRICIAN.

* * * * * * * * * * * * * *

The input power is connected to a terminal block which is located in the rear panel mounted junction box on the left (rear view). This junction box is marked "Input Voltage". Phase rotation is unimportant to this machine.

When connecting to a WYE input power form, the neutral is not connected. The green CHS wire is always connected to EARTH GROUND.

This unit is capable of many input power forms and has taps for high and low line also. See Section 6.3 for information regarding the selection of input taps.

- - - C A U T I O N - - -

CONNECTION OF THIS UNIT TO IMPROPER INPUT VOLTAGES
CAN CAUSE CATASTROPHIC DAMAGE TO THE POWER SOURCE.
READ THE INPUT VOLTAGE LABEL AND CONNECT TO THAT
INPUT VOLTAGE FORM ONLY. IF YOU HAVE ANY QUESTIONS,
PLEASE CONTACT THE FACTORY.

- - - - -

NOTE:

It is the user's responsibility to meet all local and national electrical codes when installing this equipment.

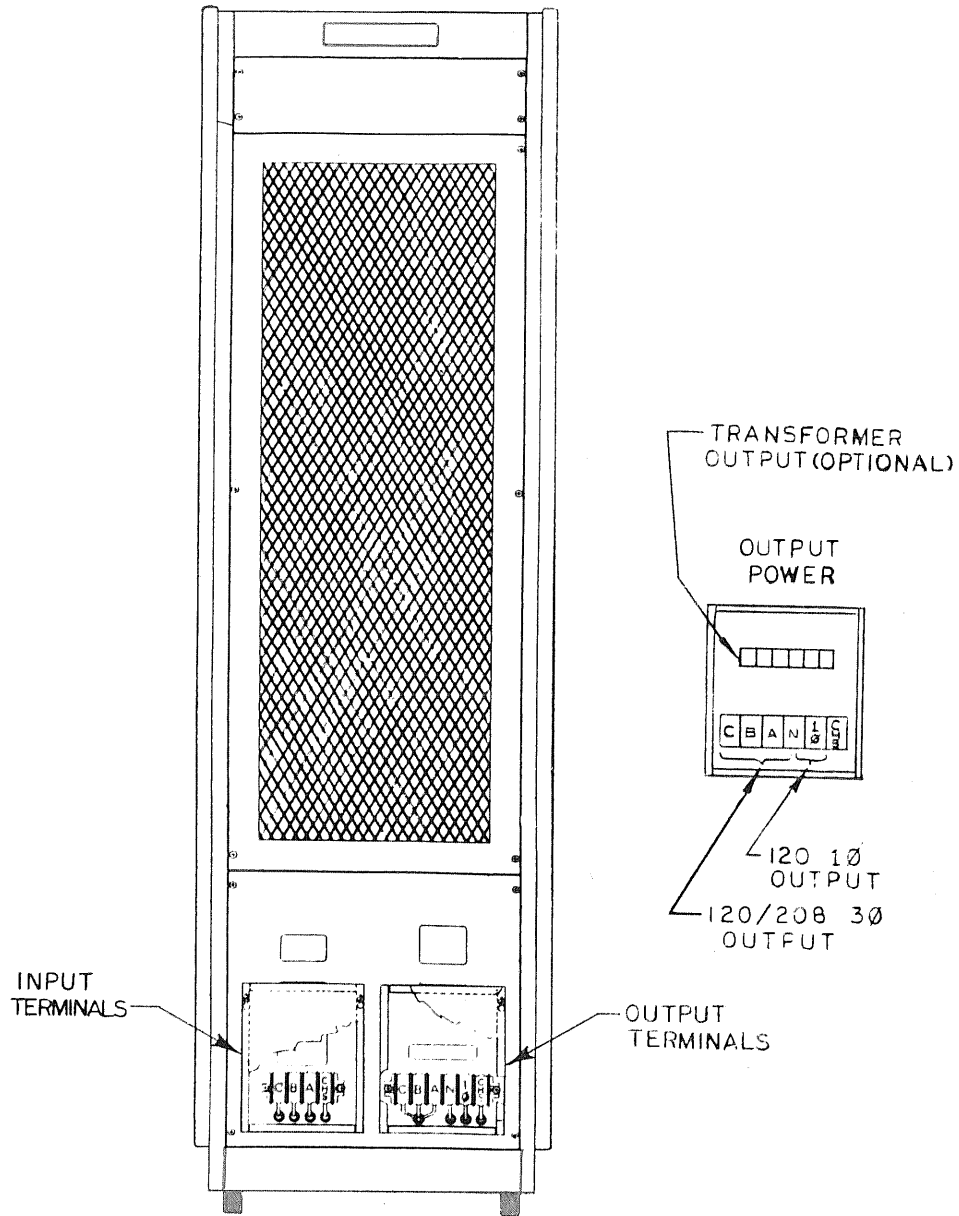

FIGURE 4-2

MODEL 390-G
INPUT/OUTPUT TERMINAL LOCATIONS

4.5 OUTPUT POWER CONNECTION

* * * W A R N I N G * * *

LETHAL VOLTAGES ARE PRESENT AT THE OUTPUT OF THIS MACHINE. REFER OUTPUT CONNECTION TO A QUALIFIED ELECTRICIAN.

* * * * * * * * * * * * * * *

The output power is connected to a terminal block which is located in the rear panel mounted junction box on the right (rear view). This junction box is marked "Output Voltage". Phase rotation is as labeled. The neutral is common to both the single and three phase output forms.

The CHS must be always be connected to the chassis of the output load. Any output terminal may be connected to CHS; however, it is recommended that the Neutral (N) terminal be connected to CHS.

Systems supplied with secondary outputs will have an additional terminal block mounted in the output junction box. Refer to Section 9 for detailed information regarding the configuration of the secondary output, if installed.

NOTE:

It is the user's responsibility to meet all local and national electrical codes when installing this equipment.

SECTION 5
OPERATION
TABLE OF CONTENTS

Para.	Title	Page
5.0	Operation	5-1
5.1	First Time Operation	5-1
5.2	Input Power - Verification of Correct Input Voltage	5-1
5.3	Power Module - Verification of Normal Operation	5-1
5.4	Control Module - Recommended Operating Sequence	5-3
5.5	Output Power - Applying the Load	5-7
5.6	Multi-cabinet Operation	5-9
5.6.1	Installation of Multi-cabinet PLC	5-11
5.6.2	Installation of Multi-cabinet UPS	5-15
5.7	Maintenance	5-17
5.8	Calibration	5-17
5.9	General Repair Procedure	5-17

LIST OF ILLUSTRATIONS

Fig.	Title	Page
5-1	Model 390-GC Front View	5-2
5-2	Control Module Controls Detail	5-4
5-1	Output Power Terminals Detail	5-8
5-4	Multi-cabinet System Wiring Diagram	5-10
5-1	Model 390-G Filter Location & Removal	5-18

5.0 OPERATION

5.1 FIRST TIME OPERATION

Before turning unit on, read through SECTION 5 completely. Refer to figure 5-1 for location of controls.

It is a good idea to temporarily disconnect the output power for first time operation. Turn the output power off, the output voltage to zero (counterclockwise) and set the oscillator to the desired frequency (301-C ONLY).

5.2 INPUT POWER -
VERIFICATION OF CORRECT INPUT VOLTAGE

Check to see that the input power and the input voltage label agree. Turn on the circuit breaker, insure that the fans are rotating freely and the Normalized Input Voltmeter is in the green region. If the Normalized Input Voltmeter is not in the green region, the input transformer taps will have to be changed.

To change taps, refer to SECTION 6.3, MAINFRAME SERVICE.

5.3 POWER MODULE -
VERIFICATION OF NORMAL OPERATION

Check that all fans are rotating freely, no failure lights are on and no current is being drawn with no load applied, except for a small amount of magnetizing current when output transformers are installed.

The switch on the front of the module turns the output of the module on and off. Always turn the switch off whenever connecting or disconnecting a power module. A power module may be removed or installed with the 390-G system on and under partial or no load.

The lights behind the fan indicate a shorted output device. A light on is no cause for alarm. The module is still operative, but at slightly reduced output power. It may be repaired at some later time when it more convenient.

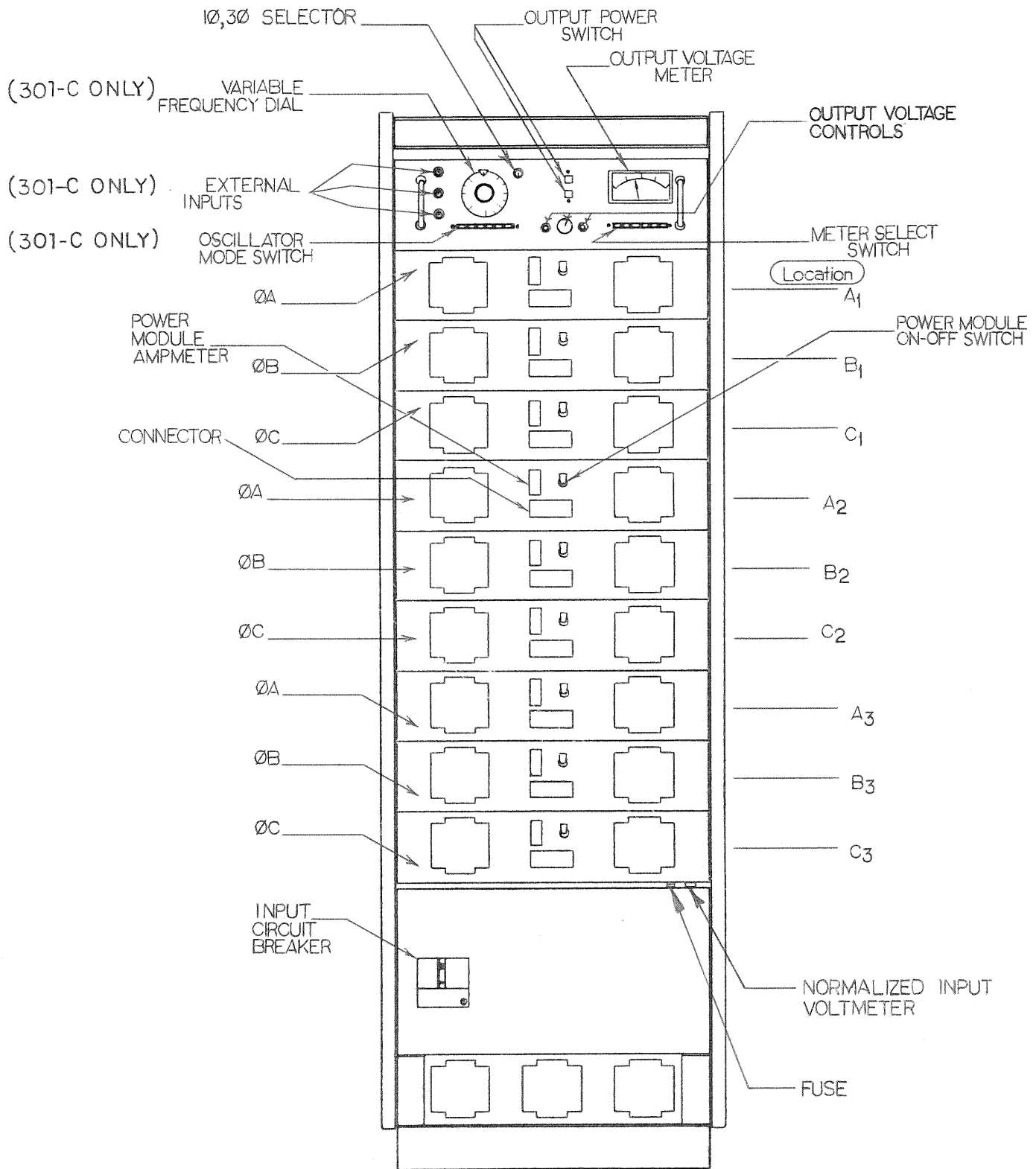

FIGURE 5-1

MODEL 390-GC
FRONT VIEW

5.4 CONTROL MODULE -
RECOMMENDED OPERATING SEQUENCE

The control module should be adjusted before the output power is applied to the load because some user equipment may be sensitive to incorrect frequency or voltage. See figure 5-2.

OSCILLATOR MODE (301-C only):

This switch selects the internal oscillator frequency or external input operation.

- 50 Hz: Selects a 50 cycle per second oscillator frequency.
- 60 Hz: Selects a 60 cycle per second oscillator frequency.
- 400 Hz: Selects a 400 cycle per second oscillator frequency.
- VAR: Selects a continuously Variable oscillator frequency, which is determined by the Variable frequency dial.
- EXT: Disables the internal oscillator and enables the ext inputs.
- SLAVE: Not used in this system.
- REL: Releases the switch so that another position may be selected.

1 PHASE/3 PHASE SELECTOR:

The 1 Phase/3 Phase key operated switch selects operation in the Single Phase mode, Three Phase mode, and enables the user to lock the Power Source Output "OFF".

EXT INPUT (301-C only):

A 0 - 2.5 VRMS small signal at the Phase A or Single Phase input will produce 18 KVA of 1 Phase power in the Single Phase mode. The machine may be used as three independent 6 KVA amplifiers in the Three Phase mode using a 0 - 2.5 VRMS signal at the Phase A, Phase B and Phase C inputs.

OUTPUT POWER:

The output power switch turns the output on or off. It is only operative when the Single Phase/Three Phase switch is in either the "1 Phase" or "3 Phase" position. The output power is disconnected when switching from single phase to three phase or three Phase to single phase.

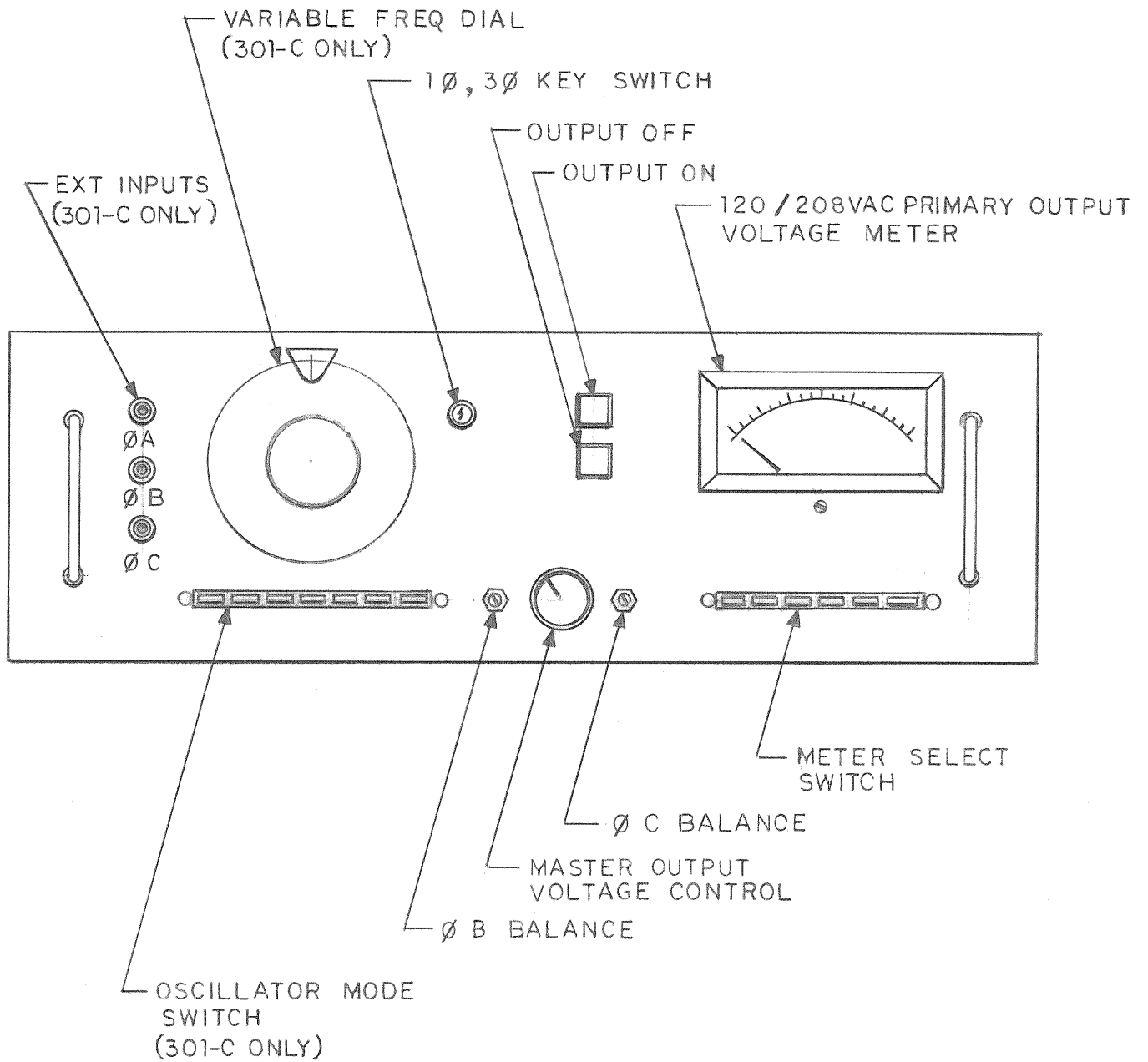

FIGURE 5-2
 CONTROL MODULE CONTROLS

5.4 CONTROL MODULE -
RECOMMENDED OPERATING SEQUENCE (con't)

VOLTAGE:

The output voltage knob adjusts the output voltage of all three phases together. The Phase B and Phase C Balance controls make fine adjustments only, and are deactivated in the Single Phase output mode.

METER SELECT:

The meter select switch determines which primary output is being displayed on the voltmeter. During single phase operation use the Phase A position.

- THIS PAGE INTENTIONALLY LEFT BLANK -

5.5 OUTPUT POWER -
APPLYING THE LOAD

* * * W A R N I N G * * *

LETHAL VOLTAGES ARE PRESENT
AT THE OUTPUT OF THIS MACHINE.

* * * * *

After all controls have been set to their desired position, turn off input power and connect your load to the power source. Only the 1 Phase or 3 Phase section of the output power will be available at any one time. In the single phase mode all power modules are in parallel. In the three phase mode modules A1, A2 and A3 are in parallel to produce Phase A. Modules B1, B2 and B3 are in parallel to produce Phase B. Modules C1, C2 and C3 are in parallel to produce Phase C.

If a failure light comes on, that power module may be turned off at a convenient time, removed from the system, repaired and replaced in the system without turning off the system. There will be a loss of a 2 KVA per power module of output power when operating with power modules removed.

There are no load imbalance restrictions on this machine. Any phase may be loaded while the others are unloaded without affecting performance in any way.

To start a motor, it may require 10 times the normal full load running current. This machine has instantaneous current limiting and will not deliver these high surge currents which are required to quickly start motors. This machine will current limit while starting the motor, causing the motor to start up slowly. This overload condition is a very severe load for this system. When this load condition is to be encountered frequently, Pacific recommends that the system be chosen to deliver these starting currents in an adequate manner. Refer to Section 2.2 for system specifications or call one of Pacific's Application Engineers when selecting the system to be used in this type of application.

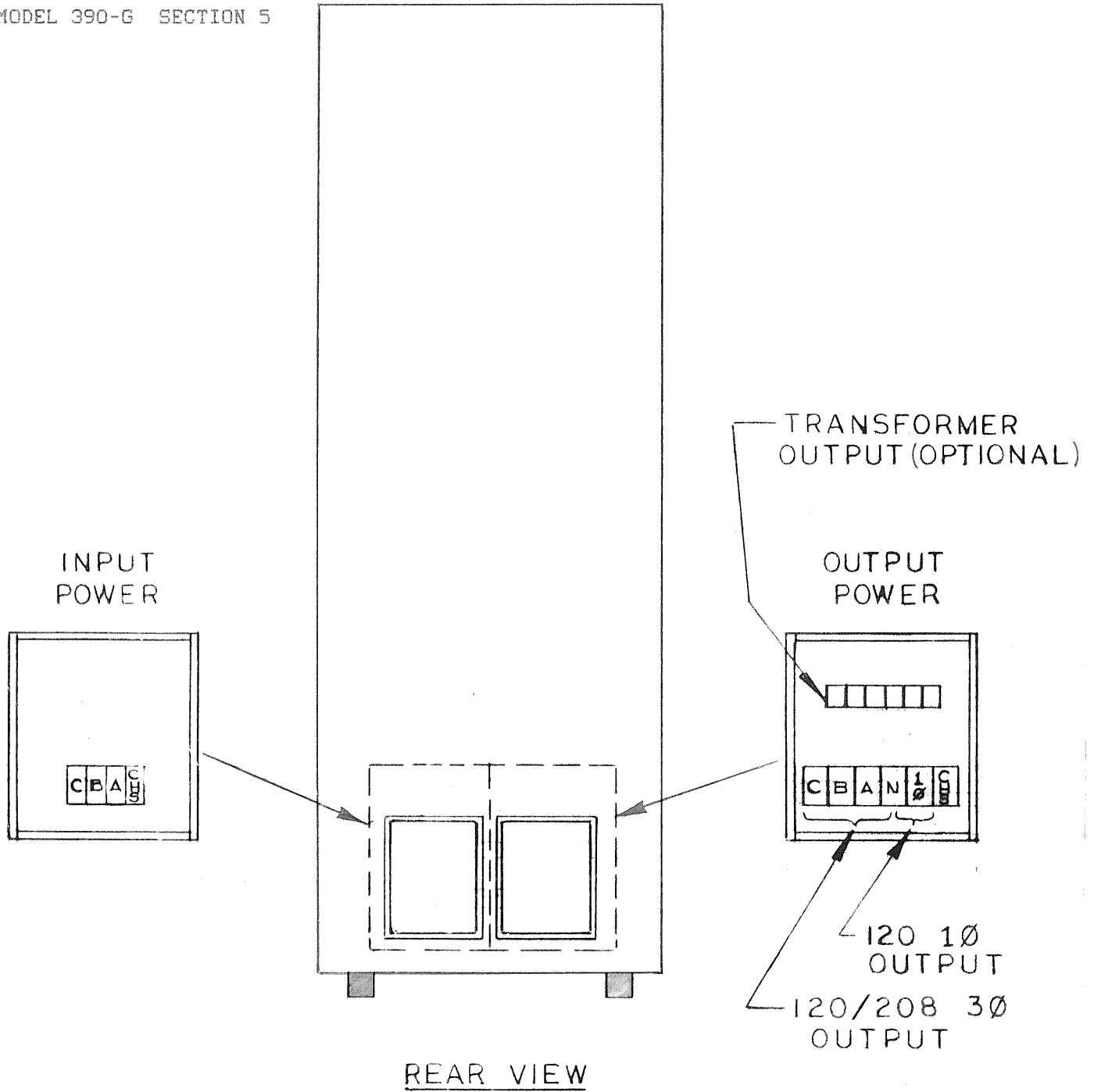

REAR VIEW

FIGURE 5-3

OUTPUT POWER TERMINALS
LOCATION DETAIL

5.6 MULTI-CABINET OPERATION

G-Series power sources (PLC) and UPS have all been designed to operate as single cabinet or multi-cabinet parallel systems. When operated singly, each cabinet has a self-contained input circuit breaker and an output contactor for load power control. Also, each cabinet has its own control module to supply drive signals to its power modules.

When operated in parallel, one cabinet is designated MASTER and all other cabinets are designated SLAVES. This is done by disconnecting all SLAVE cabinet control modules and the addition of a signal cable from the MASTER control module to all SLAVE cabinets (see Figure 5-4, opposite page). In effect the MASTER cabinet control module drives all SLAVE cabinets. The control module in each SLAVE cabinet has no function, except for cabinet tests and repairs, and for possible reversion to single cabinet or MASTER operation.

Further, when multiple cabinets are in parallel, system output ON-OFF control must be either from the MASTER cabinet or, preferably, from a special load center designed for the purpose (PPSC MODEL 3100 PC). This unit serves as a convenient tie-point for connecting all power cables together, and also provides a master load circuit breaker.

Because cabinets are tied together in so many places (input power, output power and signal cable) individual cabinets cannot be disconnected from the power grid by simply turning off cabinet input-output contactors. Special procedures are required.

From time to time it may be necessary to disconnect a cabinet from the power grid completely for maintenance purposes, or battery testing(UPS only). It may also be necessary to reassign the MASTER cabinet function. All of these operations are feasible, but require careful adherence to the procedures which follow. The figure opposite is a rear view of a typical three cabinet installation. Normally, in single cabinet operation, harness connector J5 would plug into control module connector P5. The special paralleling cable connects J5 to P1 and J1 to P5 which not only drives P5 but also provides a second connector P2 which drives J5 of a SLAVE cabinet. A second paralleling cable provides another P2 for the second SLAVE cabinet, and so forth.

Output power from all cabinets is gathered at a junction box which distributes output power to the load.

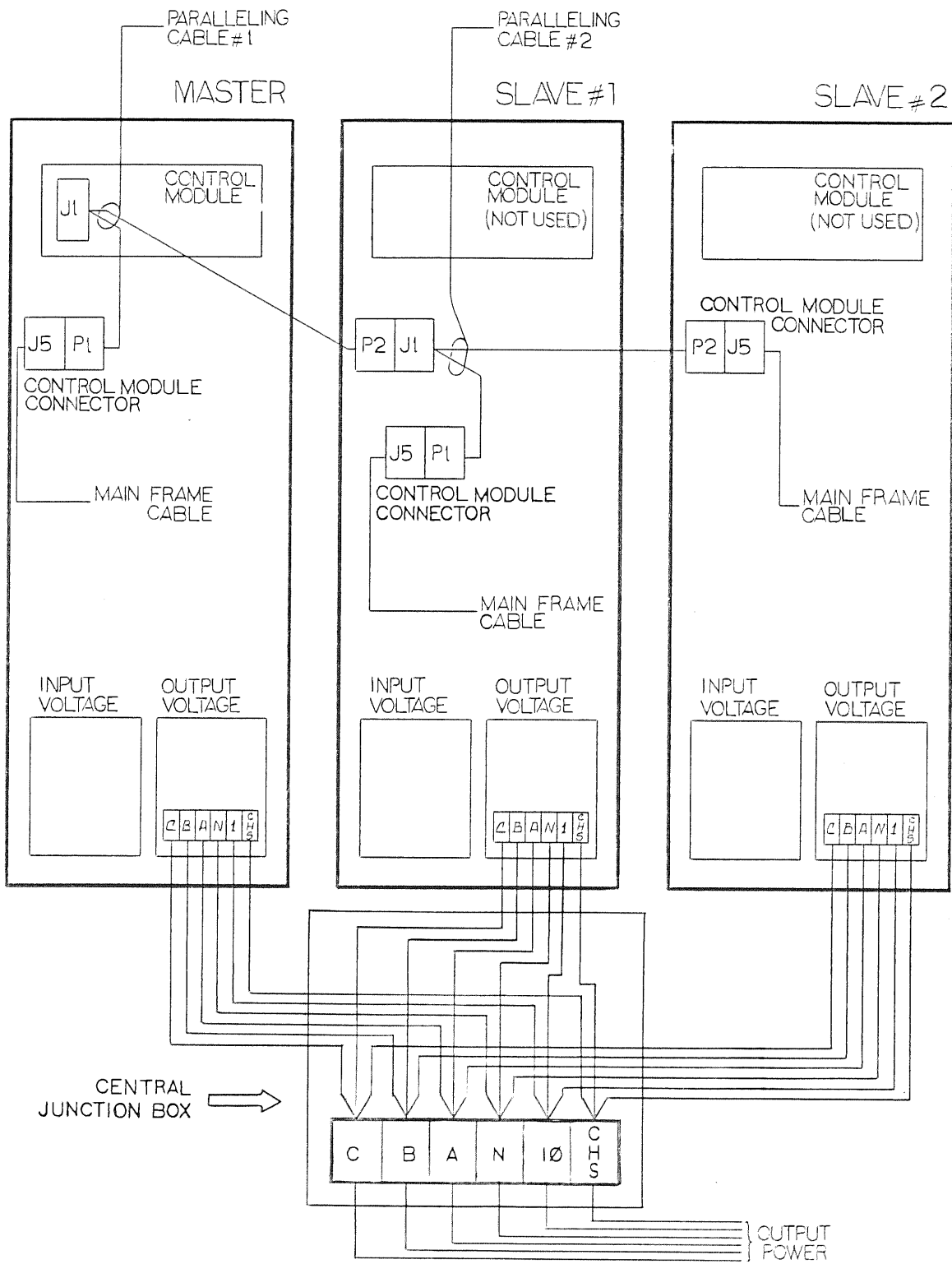

CABINET'S REAR VIEW
PARALLELING INTERCONNECT

FIGURE 5-4

WIRING DIAGRAM
MULTI-CABINET PLC
(3 CABINET SYSTEM SHOWN)

5.6.1 INSTALLATION OF MULTI-CABINET PLC

EQUIPMENT LAYOUT and CABLING

In addition to other site considerations the installer should consider the following:

1. Cabinets are best kept side by side to keep the signal paralleling cable short.
2. Input power cables from the input power mains may be as long as desired, but should be in the same room to facilitate emergency shut-down.
3. Output cables from each PLC cabinet to the 3100PC (or other power junction point if a 3100 PC is not used) should be kept short, but most importantly should be all the same length to prevent the uneven load sharing among cabinets. Lengths must match to within 1 foot and wire gauges must be identical.

* * * W A R N I N G * * *

LETHAL VOLTAGES ARE PRESENT
AT THE PARALLELING CABLE

* * * * * * * * * * * * *

- - - C A U T I O N - - -

MACHINE DAMAGE MAY RESULT IF THE PARALLELING CABLE,
OUTPUT WIRING OR TRANSFORMER TAPS (IF APPLICABLE)
ARE NOT CONNECTED PROPERLY.

MACHINE DAMAGE MAY RESULT IF THE MODEL NUMBER OR
TRANSFORMER PART NUMBERS (IF APPLICABLE) ARE NOT THE SAME.

- - - - -

INSTALLATION AND START-UP

With input power safely OFF, install all cabinets, input load center, paralleling center and system signal and power wiring. Refer to Figure 5-4 for details of interconnections.

REMEMBER, power cables from each cabinet to the paralleling point must be same size and length.

1. Input power mains must be OFF.
2. Open the front door to each power source cabinet and turn OFF the input circuit breaker and, most important, TURN OFF THE OUTPUT TOGGLE SWITCH OF EACH AND EVERY POWER MODULE, IN EACH AND EVERY CABINET.
3. Turn ON the input main breaker and the input breaker which feeds power to the MASTER cabinet.
4. At the MASTER cabinet, turn AMPLITUDE to zero (fully ccw) Turn the cabinet input circuit breaker ON.
5. Turn ON all OUTPUT switches on the power modules of the MASTER cabinet only.

Slowly increase AMPLITUDE at the MASTER cabinet control module. If any module shows significant current, stop and investigate for possible loads or shorts on system output. Increase AMPLITUDE to normal output. Energize cabinet output contactor. At the power junction point, verify with a voltmeter that 120/208 volts is present.

At this point the system is energized with only the MASTER cabinet on-line. If testing or operation with one cabinet is desired, it can be conducted at this time.

INSTALLATION AND START-UP (con't)

The addition of a SLAVE cabinet is described below. Of course, a SLAVE cabinet can only be added after normal operation with the MASTER is verified. Be sure that MASTER and all SLAVE signal cables are wired properly.

1. Reduce the output amplitude to 0 VAC.
2. At the SLAVE cabinet, energize input circuit breaker. Turn on any power module OUTPUT switch, verify no significant module current. (Module current would be abnormal since there is no system load). Turn on the other module OUTPUT switches, again verifying no module current. Continue until all switches are ON.
3. Slowly increase the output amplitude and monitor module current. If any current is shown, reduce amplitude and troubleshoot.
4. Repeat above procedure for each SLAVE cabinet.

- THIS PAGE INTENTIONALLY LEFT BLANK -

5.6.2 INSTALLATION OF MULTI-CABINET UPS

EQUIPMENT LAYOUT AND CABLING

The rules for wiring G Series UPS equipment are the same as those for PLC (par 5.6.1) systems. Because of the presence of battery cabinets, cable distances may be greater.

REMEMBER the rule for equal size and length cable from each cabinet output junction box to the power junction point. These must be matched to within ± 1 foot.

In general the UG-18 Battery Cabinet should be immediately adjacent to the PLC cabinet it serves. The DC cables connecting these two cabinets should be kept short.

* * * W A R N I N G * * *

LETHAL VOLTAGES ARE PRESENT
AT THE PARALLELING CABLE

* * * * * * * * * * * * *

- - - C A U T I O N - - -

MACHINE DAMAGE MAY RESULT IF THE PARALLELING CABLE,
OUTPUT WIRING OR TRANSFORMER TAPS (IF APPLICABLE)
ARE NOT CONNECTED PROPERLY.

MACHINE DAMAGE MAY RESULT IF THE MODEL NUMBER OR
TRANSFORMER PART NUMBERS (IF APPLICABLE) ARE NOT THE SAME.

- - - - -

INSTALLATION AND START-UP

Once the physical installation and cabling is complete, keep UG-18 DC OUTPUT circuit breakers OFF but leave input charger ON so that batteries may charge. (Performance verification and connection of the UG-18 is not included here, since this is covered in the UG-18 manual).

All PLC cabinets may be energized following the procedure of par 5.6.1. Once this is done turn on the entire system (all cabinets) and then turn on each UG-18 DC circuit breaker. The UPS is now operational.

INSTALLATION AND START-UP (con't)

A simple (no load) test can be conducted before making load connections. Simply turn OFF main input power and verify normal output at the system output bus.

This test can then be repeated with a load on the system. It is a more meaningful test with load since UPS time can be verified, as well as load sharing (indicated by module ammeters and battery recovery time).

5.7 MAINTENANCE

The 3 large and 1 small air filters located on the front door MUST be cleaned monthly. A clogged filter will cause the machine to overheat. (See Figure 5-5).

With the door open, check all fans to see if they are rotating freely and start easily. Look for failure lights or any abnormal module current as this is an indication of the need for service.

5.8 CALIBRATION

Pacific Power Source Corporation recommends calibration checks at six-month intervals. If the unit is out of calibration or has undergone major repairs, it should be re-calibrated per SECTION 6.4 or 7.4 or 8.4.

5.9 GENERAL REPAIR PROCEDURE

Pacific "G" Series equipment has been designed for repair by module exchange. Malfunctioning modules should be returned to the factory for repair. In applications which cannot tolerate down-time, it is recommended that at least one module of each type be kept on hand as spares for module recycling. The user will find that is by far the best way to effect machine repairs. It is also, in the long run, the most economical method of maintenance.

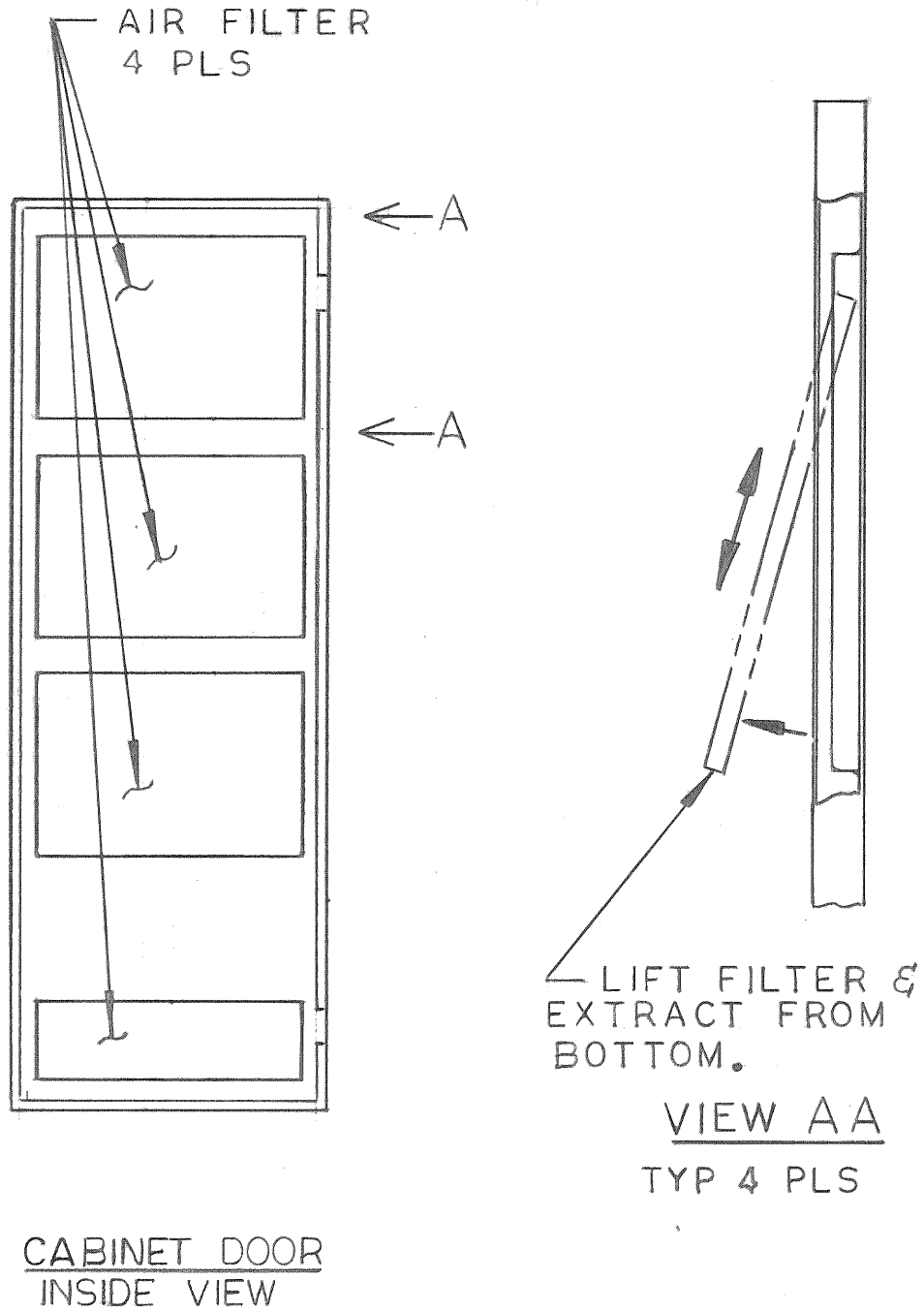

FIGURE 5-5
FILTER LOCATION AND REMOVAL

- THIS PAGE INTENTIONALLY LEFT BLANK -

SECTION 6

MAINFRAME DETAILED DESCRIPTION

TABLE OF CONTENTS

Para.	Title	Page
6.0	Mainframe Detailed Description	6-1
6.1	Description	6-1
6.2	Theory of Operation	6-7
6.3	Input Power Form Configuration	6-9
6.4	Calibration	6-22
6.5	Service	6-22

LIST OF ILLUSTRATIONS

Fig.	Title	Page
6-1	Model 390-G Assy. Dwg.	6-2
6-2(a)	Power Supply Assy. Dwg. (Sht. 1)	6-3
6-2(b)	Power Supply Assy. Dwg. (Sht. 2)	6-4
6-3	Model 390-G Mainframe Schematic	6-5
6-4	Input Transformer Schematic	6-10
6-5	Input Power Form Table	6-12
6-6	LCU Operating Points	6-14
6-7(a)	Input Power Forms Wiring Diagrams (Forms: AL, AN, AH)	6-16
6-7(b)	Input Power Forms Wiring Diagrams (Forms: CL, CN, CH)	6-17
6-7(c)	Input Power Forms Wiring Diagrams (Forms: DL, DN, DH)	6-18
6-7(d)	Input Power Forms Wiring Diagrams (Forms: EL, EN, EH)	6-19
6-7(e)	Input Power Forms Wiring Diagrams (Forms: FL, FN, FH)	6-20
6-7(f)	Input Power Forms Wiring Diagrams (Forms: GL, GN, GH)	6-21

6.0 MAINFRAME DETAILED DESCRIPTION

6.1 DESCRIPTION

The mainframe consists of the cabinet, input power supply, and interconnecting cables. Refer to Figures 6-1 and 6-2 for parts location.

The parts listed below are listed by PPSC part number. When ordering replacement parts be prepared to supply the model and serial numbers of the units to be repaired. This will ensure an efficient response to your needs.

MODEL 390-G MAINFRAME ASSY
MATERIAL LIST

Reference Figure 6-1

ITEM NUMBER	SYMBOL	DESCRIPTION	PPSC P/N
1		CABINET	114204-C
4		LABEL OUTPUT	114206
5	T1	TRANSFORMER	531194
6		LABEL HIGH VOLTAGE	704001
7		CABLE ASSEMBLY	114201-E
9		LABEL OUTPUT	114203
11		LABEL (SAT)	580026
13		LABEL (SAT)	580028
15		POWER SUPPLY	114220-A
19		MOUNTING TAB	779138
31		TERMINAL BLOCK COVER	705010
33		TERMINAL BLOCK COVER	705010
35		T. B. END SECTION	705007
43		GROMMET	702029
71		CHOKE MTG PLATE	114307
73		CHOKE	730002

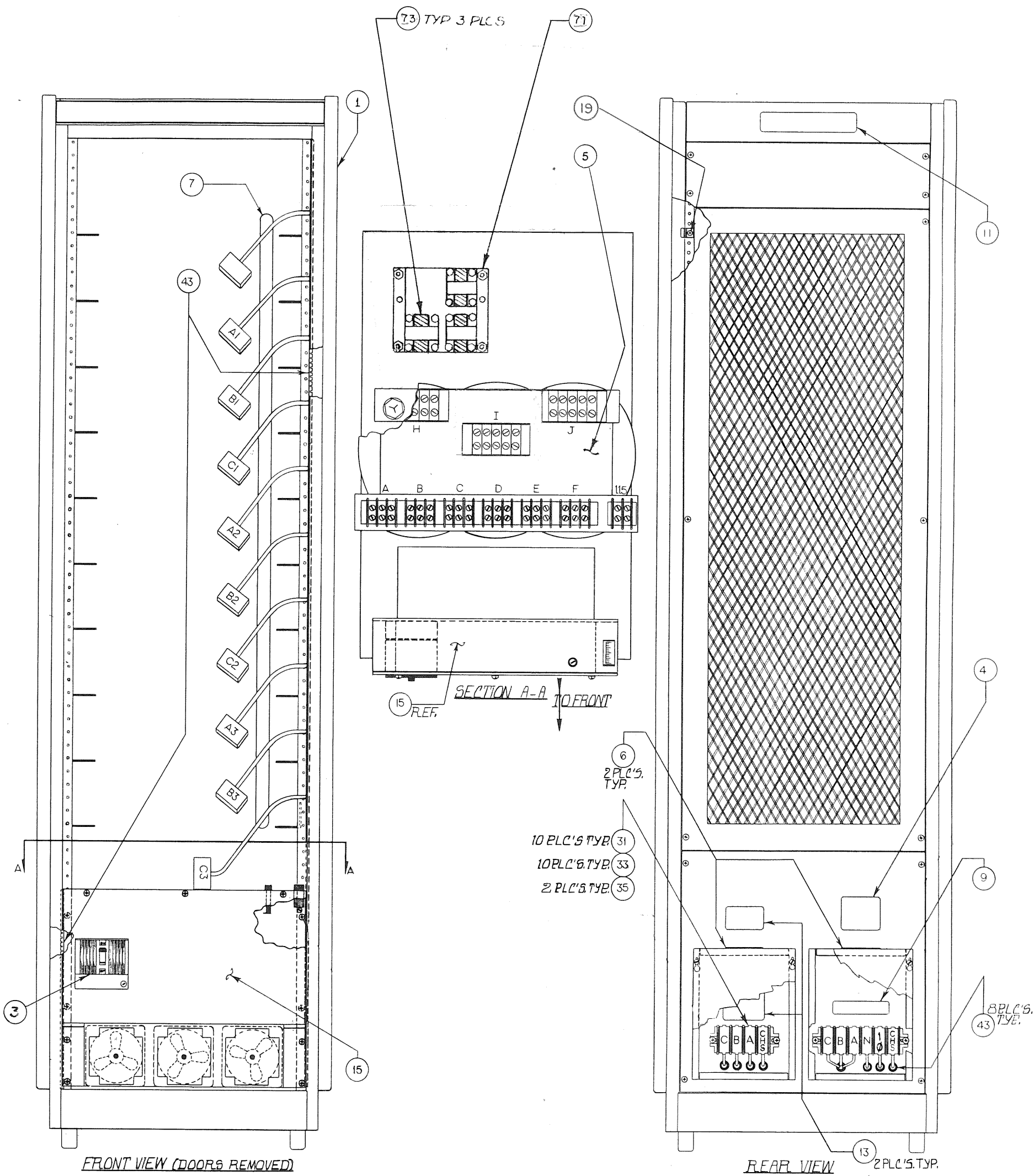

FIGURE 6-1

MODEL 390-G
MAINFRAME ASSY DWG.

390-G MAIN FRAME
ASSEMBLY
6-2

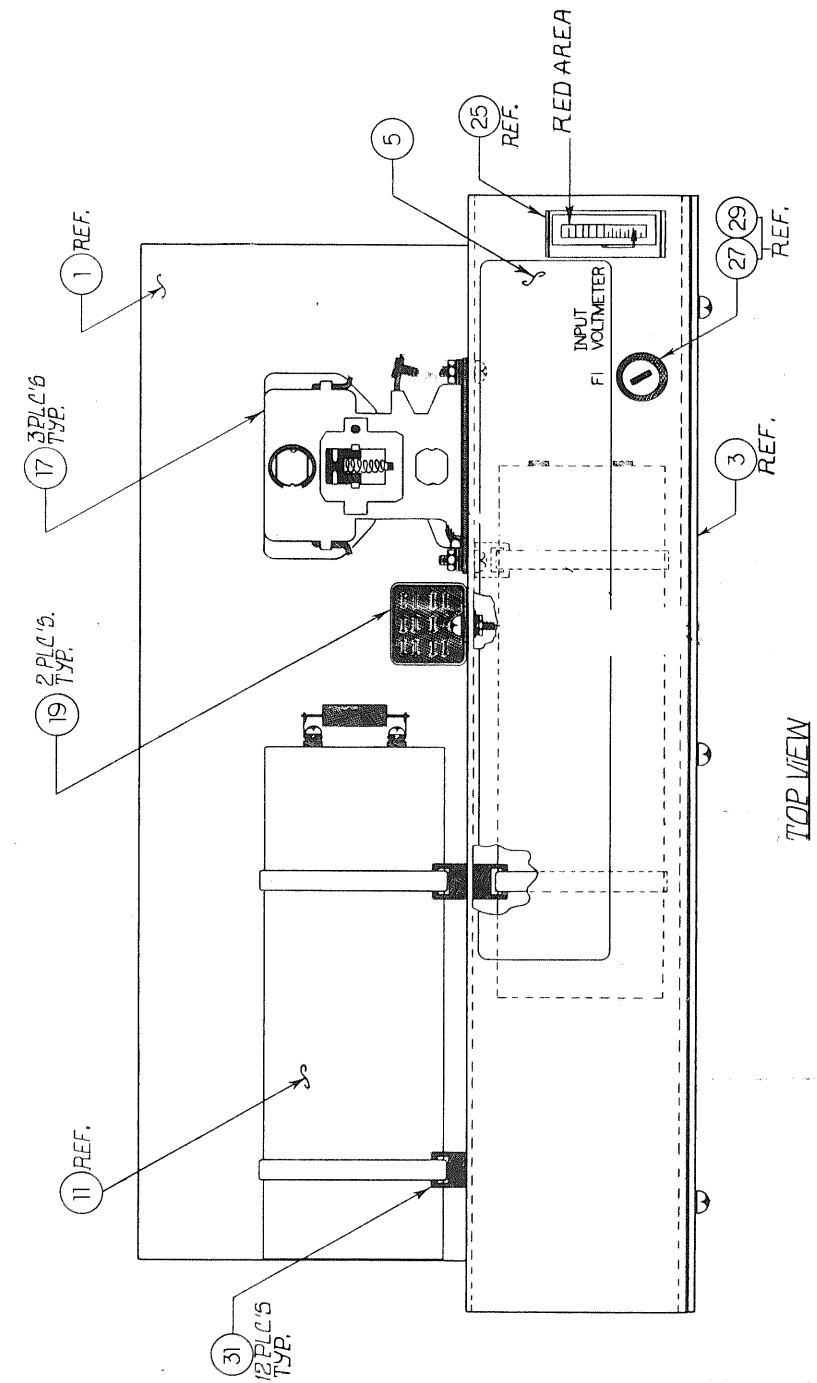
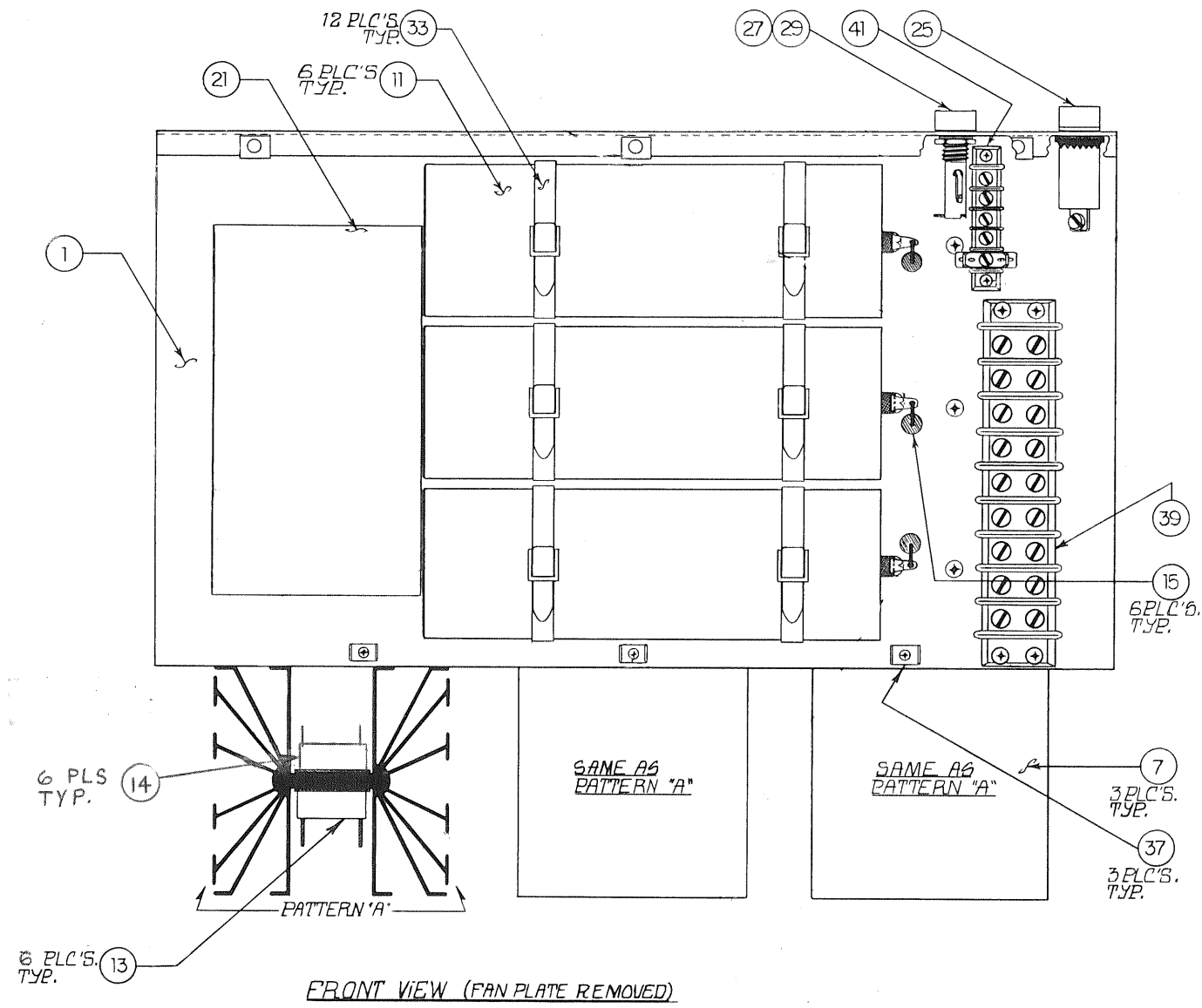
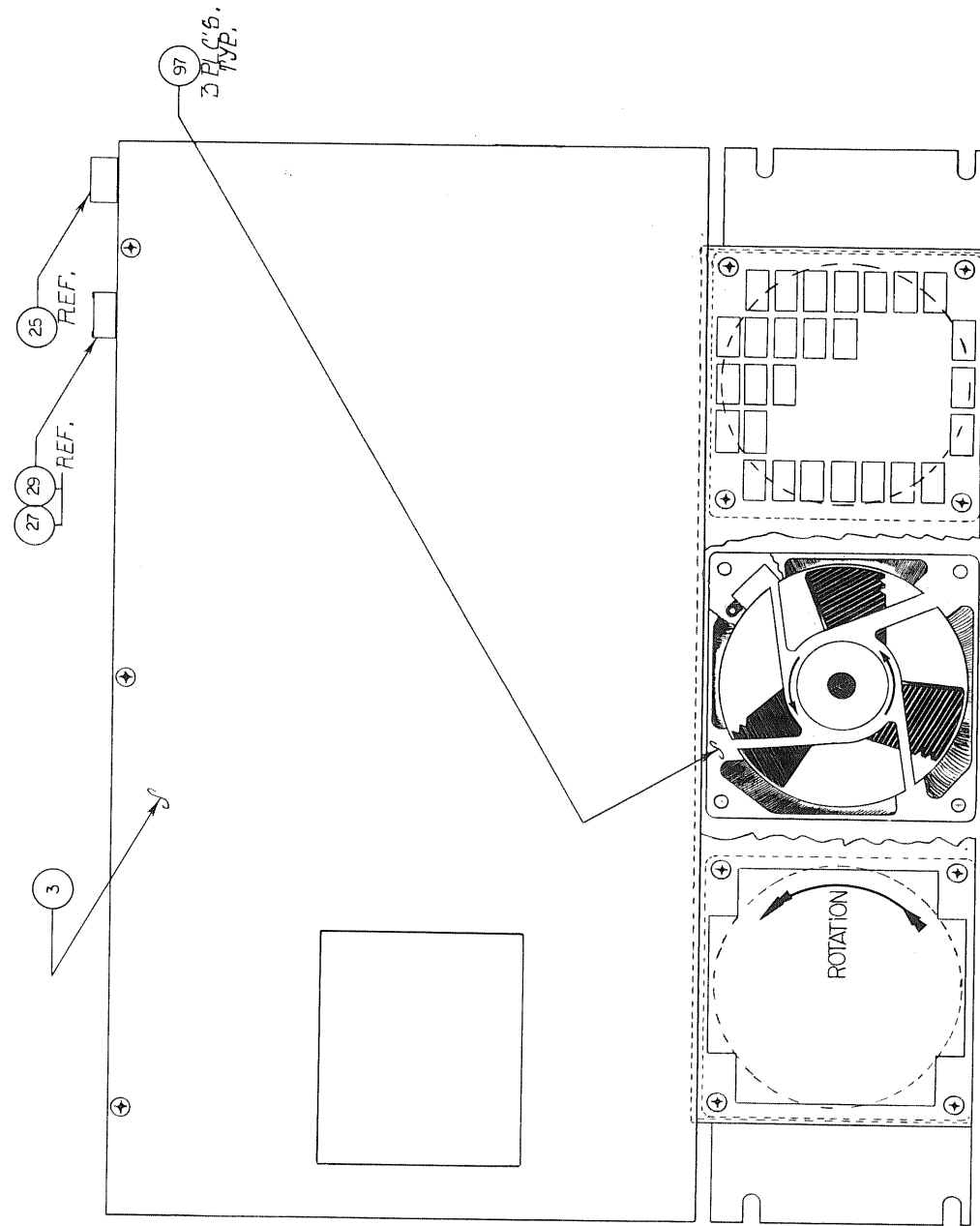
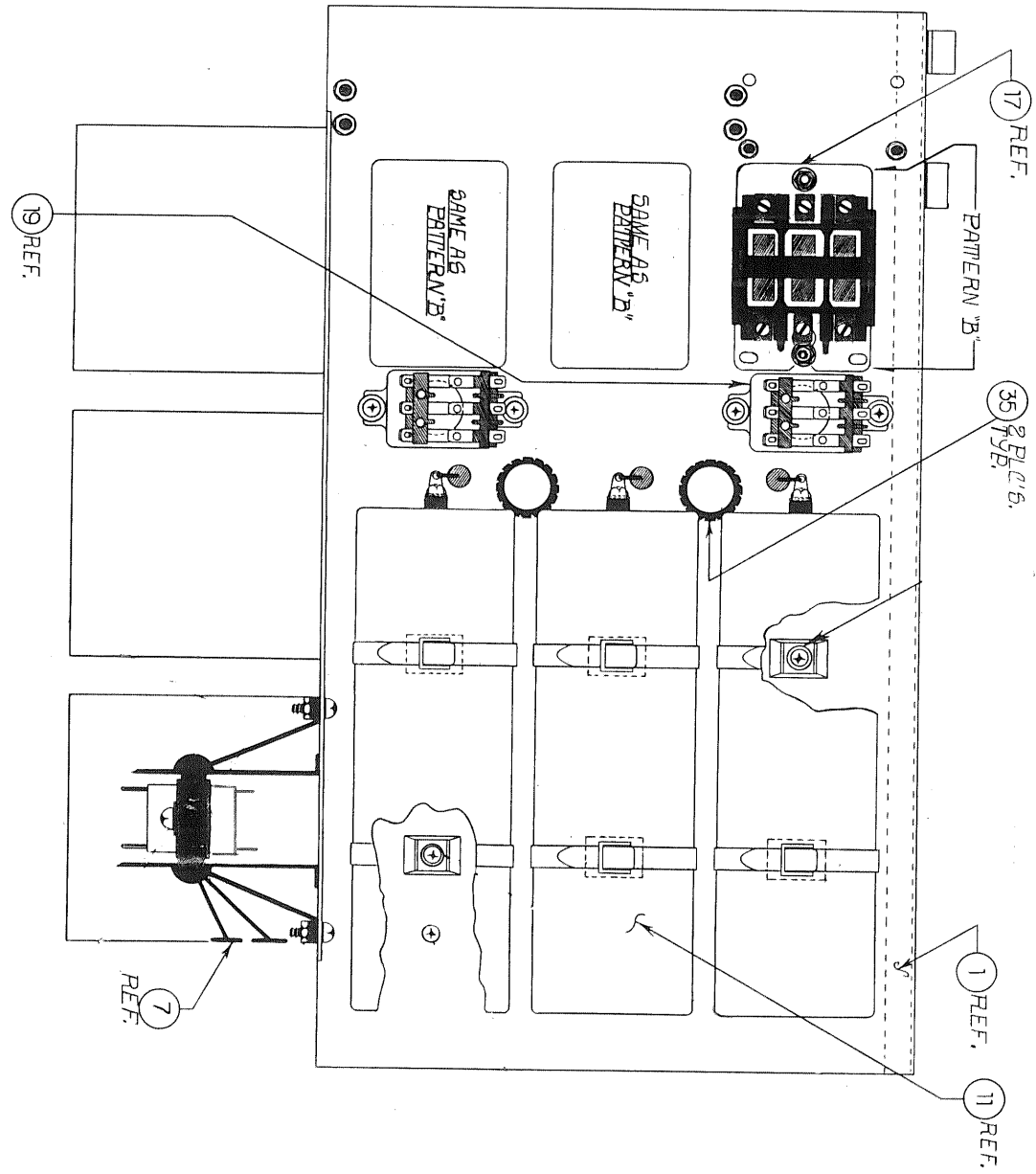

FIGURE 6-2(a)
 MODEL 390-G
 MAINFRAME ASSY DWG.
 POWER SUPPLY DETAIL
 6-3

REAR VIEW



FAN PLATE (FRONT VIEW)

FIGURE 6-2(b)
MODEL 390-G
MAINFRAME ASSY DWG.
POWER SUPPLY DETAIL
6-4

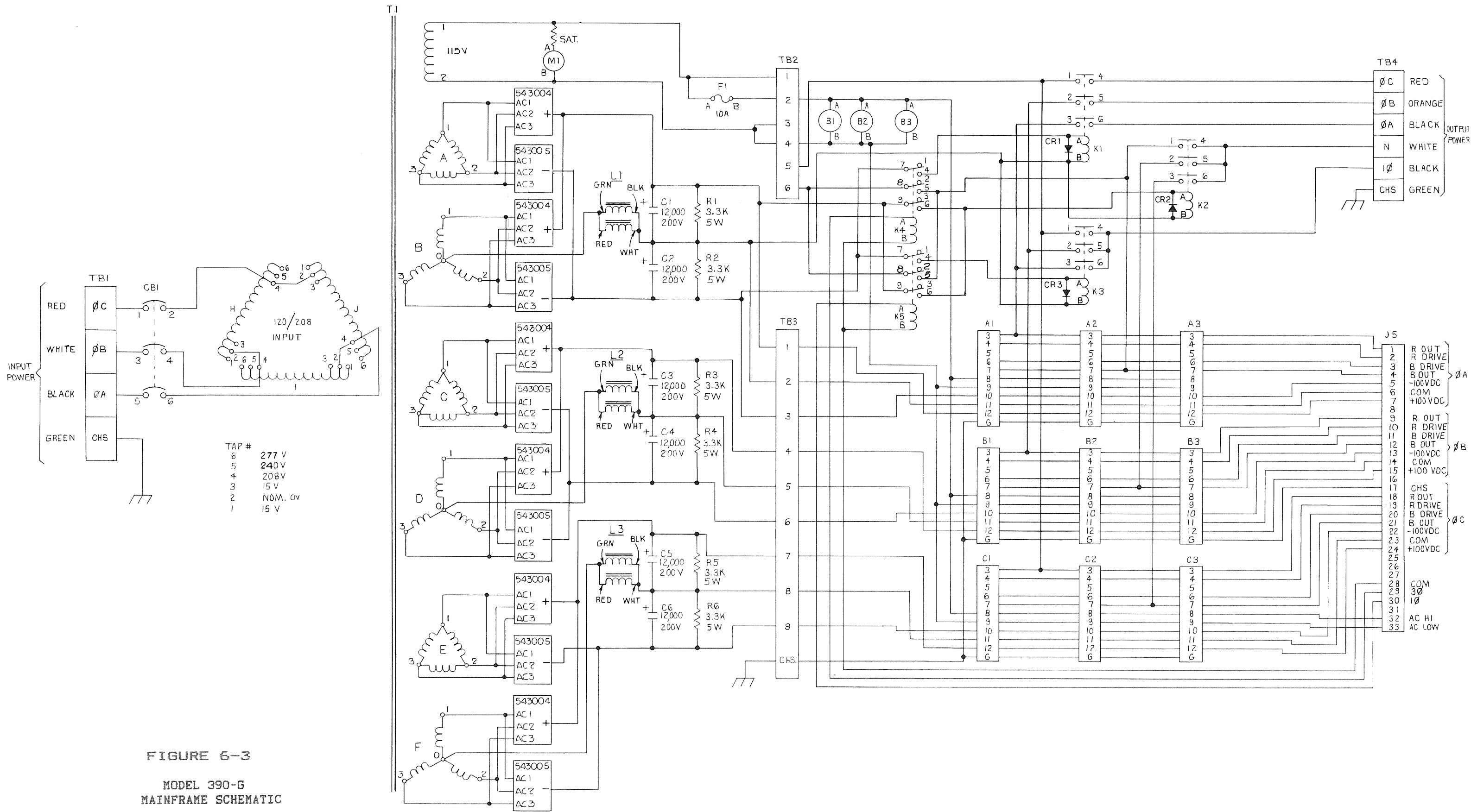

FIGURE 6-3
MODEL 390-G
MAINFRAME SCHEMATIC

6.1 DESCRIPTION (con't)

MODEL 390-G MAINFRAME ASSY
 POWER SUPPLY DETAIL
 MATERIAL LIST

Reference Figure 6-2(a) & 6-2(b)

ITEM NUMBER	SYMBOL	DESCRIPTION	PPSC P/N
1		Power Supply Plate	114211
3		Fan Plate	114212
5		Label	114213
7		Heatsink	106705A
9		Diode	741001
11	C1-C6	Capacitor 12,000 UF 200 VDC	720209-12
13	BR1-BR6	3 Phase Com. Cathode Half wave bridge	543004
14	BR7-BR12	3 Phase Com. Anode Half wave bridge	543005
15	R1-R6	Resistor, 3.3K 5W10%	760292-33
17	K1-K3	Contactors	717008
19	K4-K5	Relay	717002
21		Circuit Breaker, Insulator	114214
25	M1	Meter % Volts	500026
27	F1	Fuse Holder	712006
29		Fuse	712025
31		Capacitor Block	779128
33		Capacitor Strap	779124
35		Grommet	702029
37		Wiring Block	779130
39	TB3	Terminal	705004
41	TB2	Terminal Block 15A	705012
97	B1-B3	Fan	703104

6.2 THEORY of OPERATION

The input transformer is capable of many types of input voltages by reconfiguring the input taps. (See Figures 6-3 and 6-4). The input power remains the same with the different voltages and currents; therefore, the input circuit breaker must be sized accordingly for the input current of that form of input power.

The input transformer steps down the voltage and isolates the input power from the chassis and each set of ± 100 VDC. The power supply is a simple bridge-rectifier, capacitor-filtered DC power supply. It produces 3 sets of ± 100 VDC, 1 per phase. Each set of ± 100 VDC is isolated and has an AC voltage between them when operating in the three phase mode.

There is a 115 VAC winding on the input transformer. This is for fan and control module power. It also operates the Normalized Input Voltmeter (NIV). This NIV monitors the incoming line voltage and informs the user if he should change input transformer taps, so that the machine has the correct input voltage. It should be in the green area. Continued operation in the red region will result in reduced reliability of the system. Operating below the 90% point will cause clipping of the output voltage. However, this condition is not damaging to PLC systems. A UPS operating in the white region will draw power from the batteries prematurely, a condition which should not be permitted.

MODEL 390-G SECTION 6

- THIS PAGE INTENTIONALLY LEFT BLANK -

6.3 INPUT POWER FORM CONFIGURATION

All G-Series power source cabinets (330-G, 360-G, 390-G, 330-UG, 360-UG, 390-UG and parallel combinations thereof) are equipped with a universal input power transformer. This is a fully isolated and shielded three phase transformer with three separate tapped primary windings, (see Figure 6-4, opposite). By connecting these three windings in various ways - WYE and DELTA - and by utilization of taps, almost any input power form can be accommodated.

Regardless of whether primary windings are in WYE or DELTA orientation, the input power form used is always configured as 4 wire DELTA (3 phases and frame ground). When input service is WYE, the neutral wire is not required and is not used. This is because G-Series cabinets always present a balanced load to input service with no significant neutral current. This is true even when the G-Series output is single phase or unbalanced three phase.

Because of its versatility, the input transformer can easily be miswired. Strict adherence to the instructions of this manual is required. A NORMALIZED INPUT VOLTMETER (NIV) on the power supply panel indicates if the correct tap is used. Always use the lowest internal voltages which can be tolerated for cool operation and best reliability.

Consider the schematic of the transformer primary as shown on Figure 6-4, opposite.

The voltages shown are primary voltages at nominal input excitation. The Power Source is designed to accept the input voltages shown $\pm 10\%$. Figure 6-5 lists the nominal input voltage forms which can be accommodated. The input current shown is the maximum input current which is required to operate the system at full load.

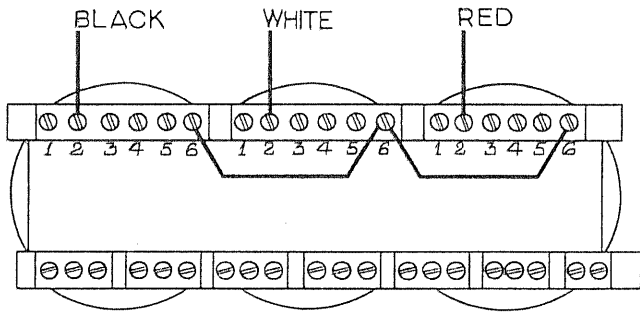
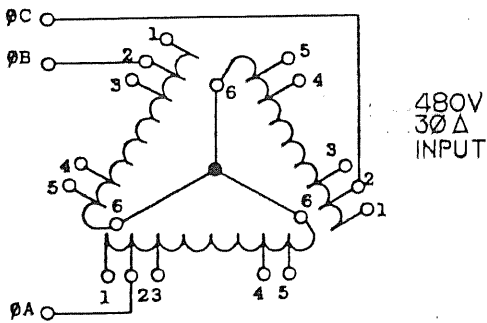
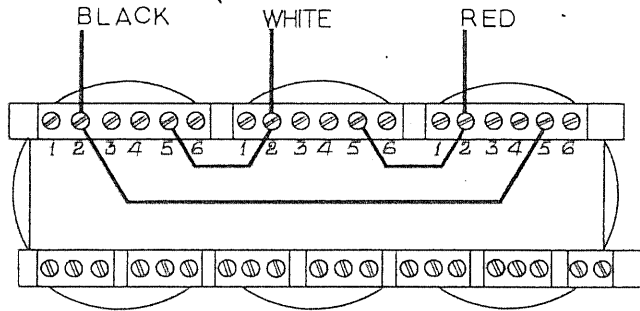
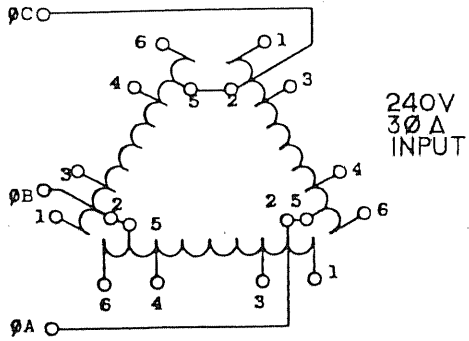
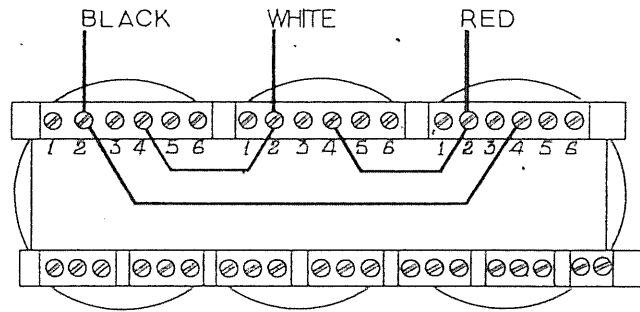
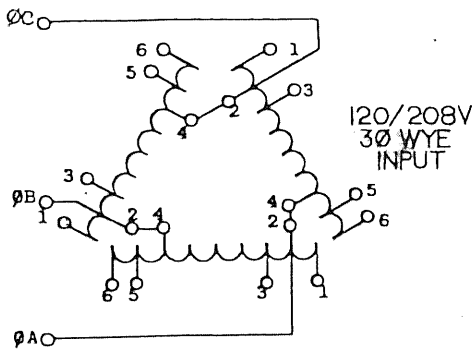

INPUT CURRENT

INPUT VOLTAGES	INPUT CURRENTS
120/208V 3ØY	78 A
240V 3ØΔ	68 A
480V 3ØΔ	34A

FIGURE 6-4

MODEL 390-G
INPUT TRANSFORMER SCHEMATIC

MODEL 390-G SECTION 6

- THIS PAGE INTENTIONALLY LEFT BLANK -

INPUT POWER FORMS

INPUT FORM	MAX AMPS PER PHASE	NOMINAL INPUT VOLTAGE VL-L	APPLICATION
CL	84	193 ± 10%	120/208 WYE (LOW LINE)
CN	78	208 ± 10%	120/208 WYE
CH	73	223 ± 10%	120/208 WYE (High Line) 220 DELTA
AL	72	225 ± 10%	220 DELTA 240 DELTA (Low Line)
AN	67	240 ± 10%	240 DELTA
AH	63	255 ± 10%	240 DELTA (High Line) 260 DELTA
GL	62	262 ± 10%	260 DELTA
GN	58	277 ± 10%	260 DELTA (High Line)
GH	55	292 ± 10%	NOT COMMONLY USED
EL	48	334 ± 10%	NOT COMMONLY USED
EN	45	360 ± 10%	220/380 WYE (Low Line)
EH	42	386 ± 10%	220/380 WYE
FL	42	390 ± 10%	220/380 WYE 240/416 WYE (Low Line)
FN	39	416 ± 10%	220/380 WYE (High Line) 240/416 WYE
FH	37	442 ± 10%	220/380 WYE (High Line) 440 DELTA 480 DELTA (Low Line) 277/280 WYE (Low Line) 240/416 (High Line)
DL	36	454 ± 10%	440 DELTA (Nominal) 480 DELTA (Low Line) 277/480 DELTA (Low Line)
DN	34	480 ± 10%	480 DELTA 277/480 WYE
DH	32	506 ± 10%	480 DELTA (High Line) 277/480 WYE (High Line)

FIGURE 6-5
INPUT POWER FORM TABLE

6.3 INPUT POWER FORM CONFIGURATION (con't)

LINE CONDITIONING UNIT (LCU)

Some applications experience unusually wide fluctuations in input voltage. In these cases, G-Series units can be equipped with Line Conditioning Units (LCU) which select between high, nominal and low primary taps for each configuration. This selection is manual for power sources (PLC), and can be manual or automatic for Uninterruptible Power Systems (UPS).

When applied to PLC equipment (non-UPS) the input voltage variation which can be tolerated is still $\pm 10\%$ about the nominal value. However, that nominal value (high, nominal or low line tap, about 7% apart) can be conveniently selected via a rotary switch located on the rear of the unit. Power must be OFF when this is done.

When the LCU is installed in UPS equipment, it can be placed in the automatic mode of operation, in which case selection between the three taps is automatic. The equipment is not turned off during tap changes and power to the load is not disturbed, since the batteries supply power while contactors effect the tap selection.

UPS systems equipped with LCU have extended input line range. If the input line sags so low that even the low line tap will not sustain system output, the equipment switches to battery operation until normal line voltage resumes.

Figure 6-6, opposite, shows the approximate points where the LCU changes taps. Notice that the unit selects taps at different voltages for "increasing line" or "decreasing line" conditions. This hysteresis is normal and is designed to prevent excessive switching of the LCU contactors. The line voltages shown as switch points are very approximate. This is because the LCU and batteries switch by sensing internal DC voltages rather than line AC. DC voltages are strongly influenced by load on the system - thus the AC uncertainty. LCU Switching occurs as follows:

<u>DC Voltage</u>	<u>Action</u>
95 - 108 VDC	None
Over 108 VDC	Switch to next higher tap
Less than 95 VDC	Switch to next lower tap
Less than 90 VDC	Switch to batteries

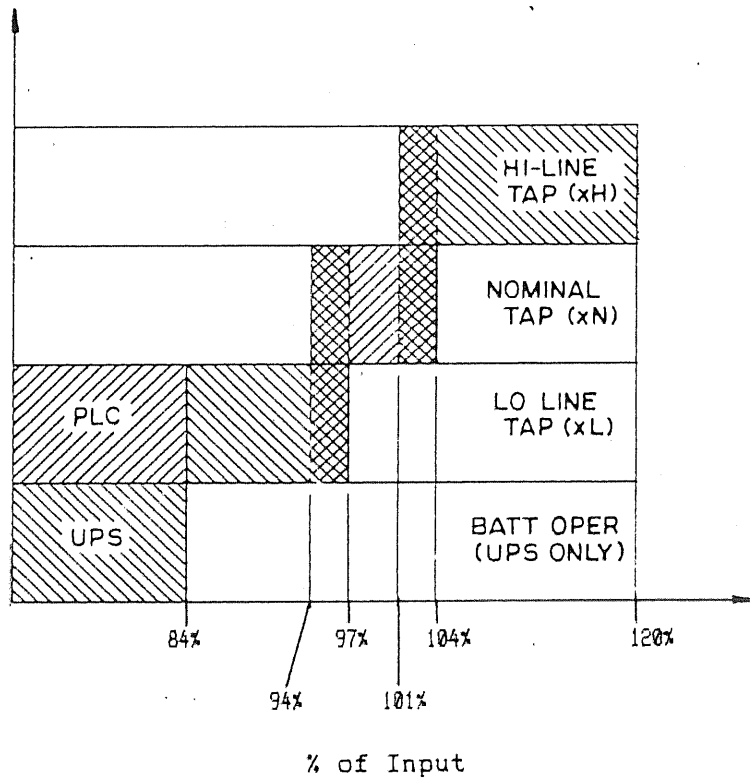

NOTE:

1. Below 84% input UPS will switch to battery operation. PLC will continue to operate on Low-line tap.
2. Shaded areas show region of operation when LCU is in the Automatic Mode of operation.

FIGURE 6-6

LCU OPERATING POINTS

6.3 INPUT POWER FORM CONFIGURATION (con't)

PRIMARY CONFIGURATIONS
UNIVERSAL INPUT POWER TRANSFORMER

Eighteen primary configurations are available. Each is listed below with a pictorial diagram of the terminal strip at the top of the transformer, and interconnecting links if any. VA, VB and VC refer to the three input power phases. The Model 390-G is not sensitive to input phase rotation and may be connected either ABC or BAC power forms.

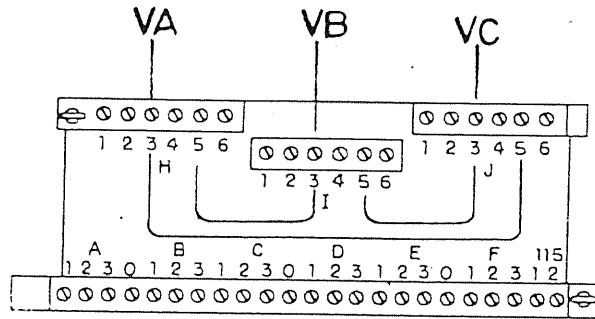

225 $V_{L-L} \pm 10\%$
Form AL

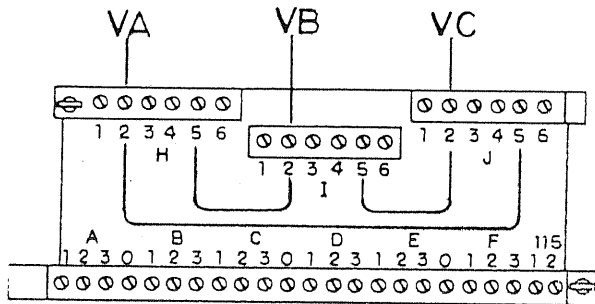

240 $V_{L-L} \pm 10\%$
Form AN

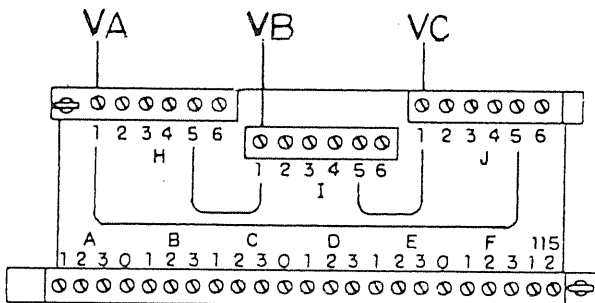

255 $V_{L-L} \pm 10\%$
Form AH

FIGURE 6-7(a)

INPUT POWER FORMS WIRING DIAGRAM

MODEL 390-G SECTION 6

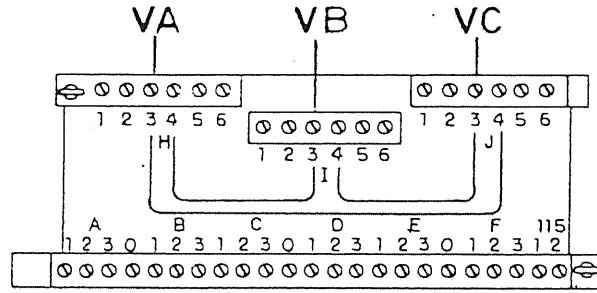

193 $V_{L-L} \pm 10\%$
Form CL

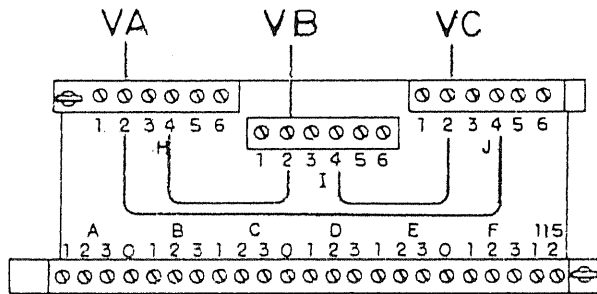

208 $V_{L-L} \pm 10\%$
Form CN

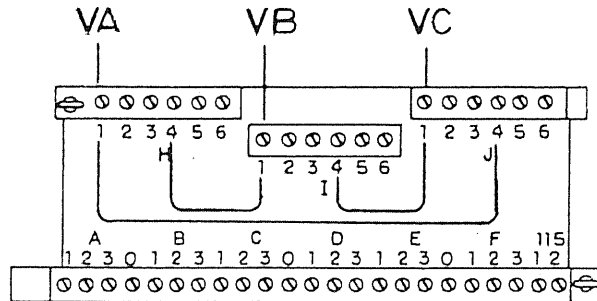

223 $V_{L-L} \pm 10\%$
Form CH

FIGURE 6-7 (b)

INPUT POWER FORMS WIRING DIAGRAM

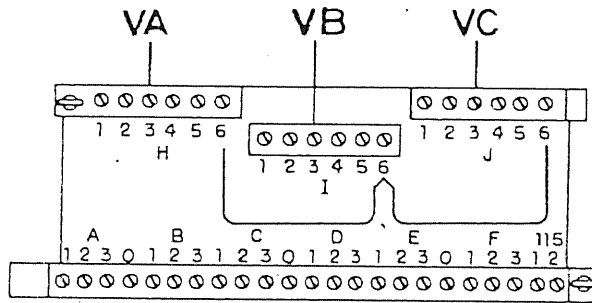

454 $V_L-L \pm 10\%$
Form DL

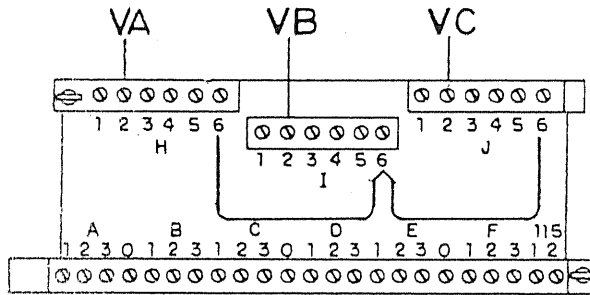

480 $V_L-L \pm 10\%$
Form DN

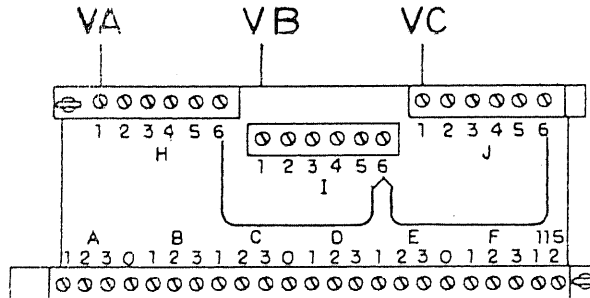

506 $V_L-L \pm 10\%$
Form DH

FIGURE 6-7(c)

INPUT POWER FORMS WIRING DIAGRAM

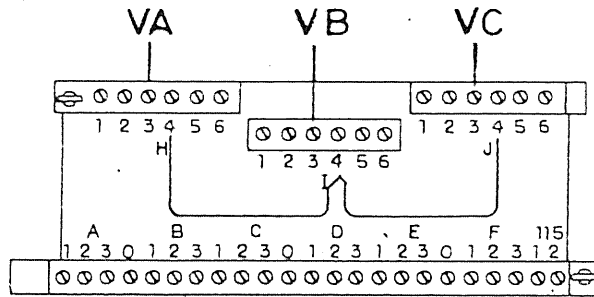

334 $V_L-L \pm 10\%$
Form EL

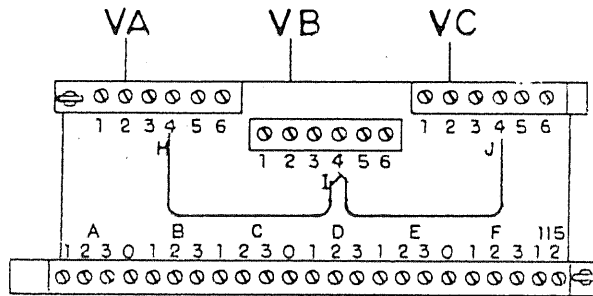

360 $V_L-L \pm 10\%$
Form EN

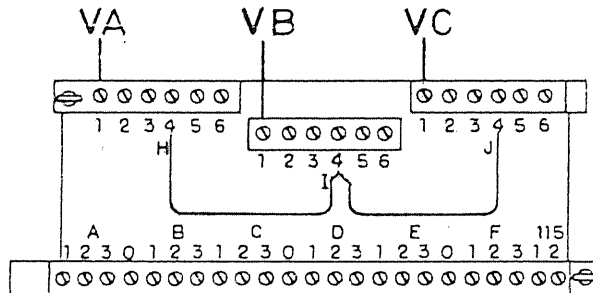

386 $V_L-L \pm 10\%$
Form EH

FIGURE 6-7(d)

INPUT POWER FORMS WIRING DIAGRAM

MODEL 390-G SECTION 6

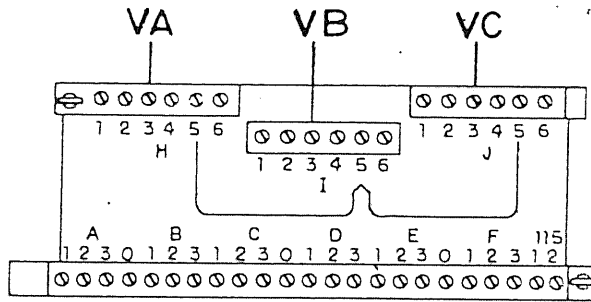

390 VL-L \pm 10%
Form FL

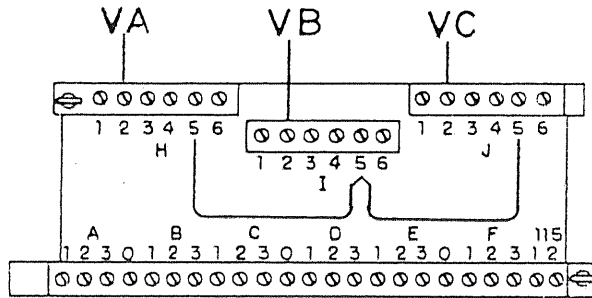

416 VL-L \pm 10%
Form FH

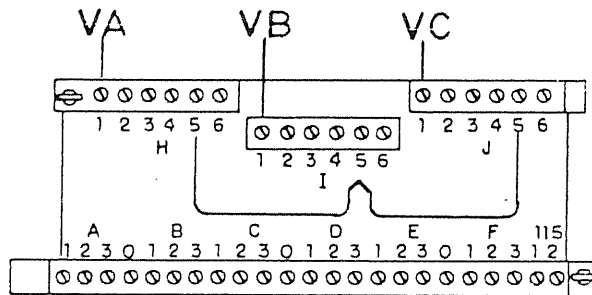

442 VL-L \pm 10%
Form FH

FIGURE 6-7(e)

INPUT POWER FORMS WIRING DIAGRAM

MODEL 390-G SECTION 6

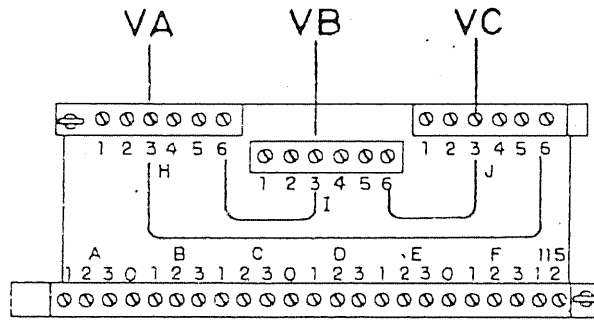

262 $V_{L-L} \pm 10\%$
Form GL

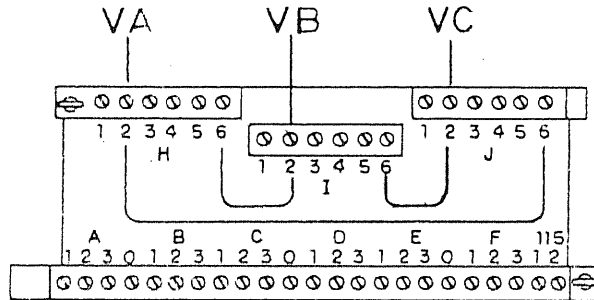

277 $V_{L-L} \pm 10\%$
Form GN

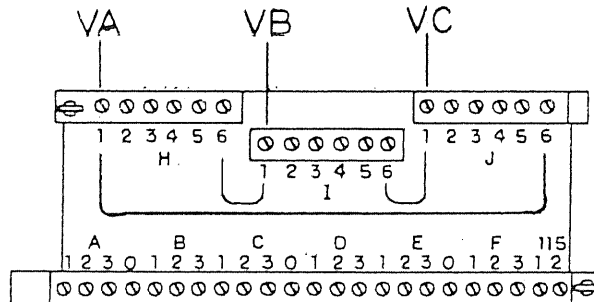

292 $V_{L-L} \pm 10\%$
Form GH

FIGURE 6-7(f)

INPUT POWER FORMS WIRING DIAGRAM

6.4 CALIBRATION

The Normalized Input Voltmeter is the only item in the mainframe that requires calibration. The Normalized Input Voltmeter should read the same as any DC supply voltage with full load applied. Example: 103 VDC should read 103% \pm 2%.

6.5 SERVICE

* * * W A R N I N G * * *

LETHAL VOLTAGES INSIDE.

DISCONNECT INPUT POWER BEFORE SERVICING.

* * * * *

The input transformer can be configured for operation off most common power mains by connecting the input as a WYE or DELTA and for either high or low line voltages. Taps 1, 2 and 3 are high line, nominal and low line taps respectively. The wires from the circuit breaker are wired to the desired taps on the input transformer. See figure 6-4. If input voltage form has been changed, be sure to change the input voltage label and circuit breaker. If the Normalized Input Voltmeter is in the red, move the input to a high line tap, tap 1. If the normalized input voltmeter is below the 90% mark, move the input to a low line tap, tap 3. To access the taps, remove the bottom 120-G power module and the rear screen. The input transformer is located in the middle of the base.

If the mainframe is suspect of a problem, check all the \pm 100 VDC and 115 VAC on all the connectors A1-C1. Refer to figure 6-3. To access the power supply, open the filter door, remove the fan plate, with the 3 fans at the bottom of the mainframe. Now the input circuit breaker and part of the power supply is exposed.

To remove the power supply, first remove the 3 bottom 120-G power modules. Remove the 4 mounting screws which attach it to the front mounting angles. Slide the power supply forward a few inches and with a short screwdriver remove all wires from the contactors in the rear of the power supply and mark their location. Remove all other wires and mark their location also. Now the power supply can be pulled out the front.

- THIS PAGE INTENTIONALLY LEFT BLANK -

SECTION 7
MODEL 120-G0
DETAILED DESCRIPTION

TABLE OF CONTENTS

Para.	Title	Page
7.0	Model 120-G0 Detailed Description	7-1
7.1	Description	7-1
7.1.1	Model 120-G0 Chassis Assy Material List	7-3
7.1.2	Model 120-G0 Power Amplifier Assy Material List	7-7
7.2	Theory of Operation	7-9
7.3	Servicing	7-11
7.3.1	Safety Notices	7-11
7.3.2	Locating a Faulty Module	7-12
7.3.3	Removing the Module from the System	7-12
7.3.4	Installing the Module Into the System	7-13
7.3.5	Field Service of the Module	7-14
7.4	Calibration	7-15

LIST OF ILLUSTRATIONS

Fig.	Title	Page
7-1	Model 120-G0 Chassis Assy. Drawing	7-4
7-2	Model 120-G0 Power Amplifier Assy. Drawing	7-5
7-3	Model 120-G0 Power Amplifier Schematic	7-6
7-4	Model 120-G0 Power Amplifier Block Diagram	7-10

7.0 MODEL 120-GO POWER MODULE
DETAILED DESCRIPTION

7.1 PRODUCT DESCRIPTION

The Model 120-GO Power module is a self-contained 2000 VA power amplifier capable of delivering up to 125 VAC @ 16 Amps. It contains automatic disconnect driver circuits and fail-safe output stages with self-diagnostic features.

Two identical amplifier assemblies are housed in the module; each produces one-half of the output voltage. These amplifiers derive their input DC power from the mainframe and the drive signals from the control card or voltage amplifier assembly.

Neon fault indicators, visible by looking through the front panel fans, indicate any output devices which may have failed and are presently bypassed.

Each power module front panel contains a Module Output Switch (Item 11, Figure 7.1) for switching the power module onto the system output bus. A Module Output Ammeter (Item 9, Figure 7.1) is provided for diagnostic purposes.

The part number of the Model 120-GO Power Module normally used in the Model 390-G is 114000. When ordering spare power modules be sure to order them by this number.

- THIS PAGE INTENTIONALLY LEFT BLANK -

7.1.1 MODEL 120-GO POWER MODULE
MATERIAL LIST

Reference Figure 7-1

ITEM	DESCRIPTION	PPSC P/N
1	Model 120-GO Chassis	114031-B
3	Model 120-GO Front Panel Label	114032-A
4	Model 120-GO Rear Panel Label	114033
5	Fan, 4" Dia. 100 CFM	703104
9	Ammeter, 0 - 16 Amps AC	500025
11	Switch, DPST 15A @ 125 VAC	710005
13	Connector, 12 Pin Male w/ pre-gnd	714035

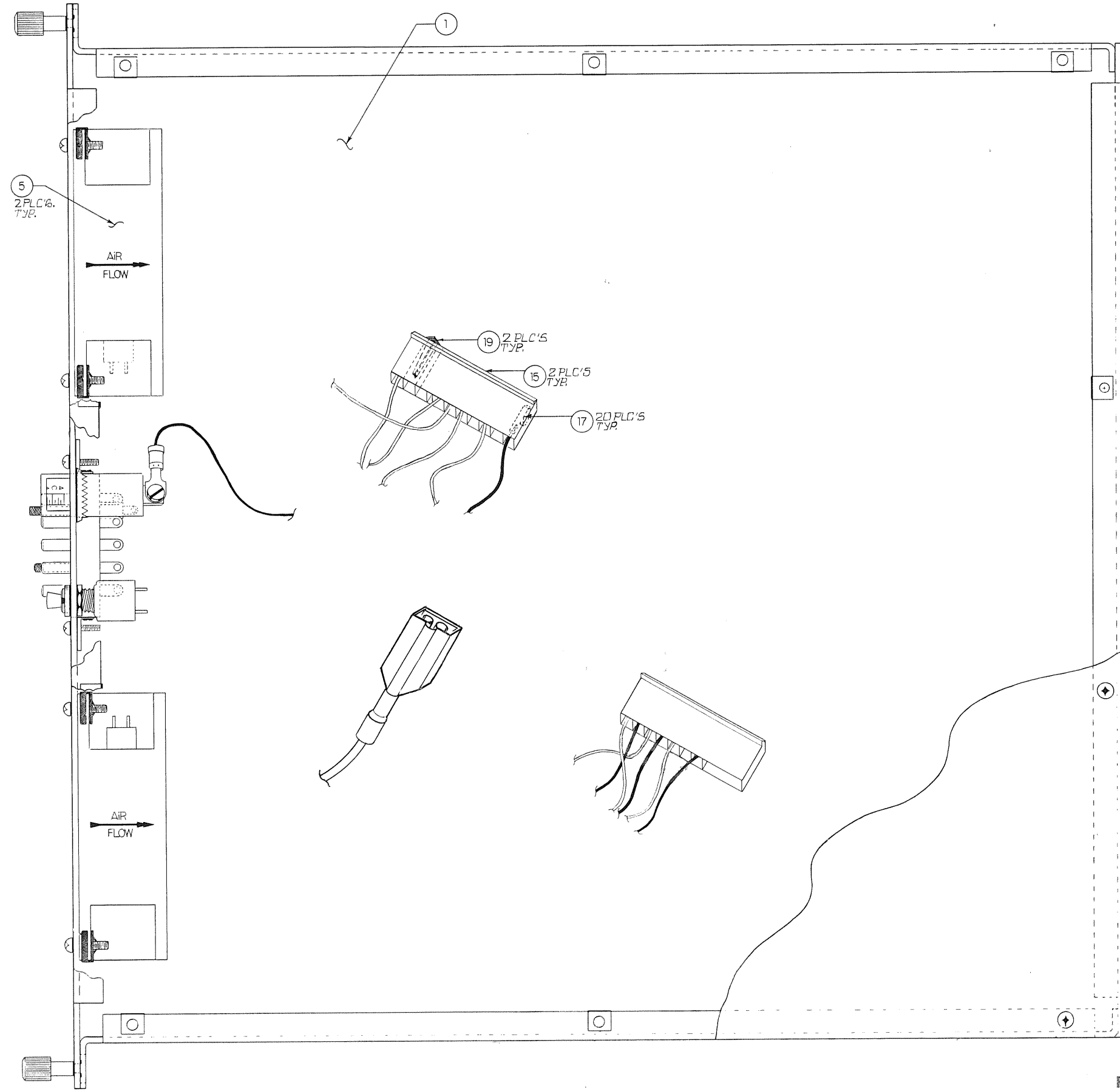
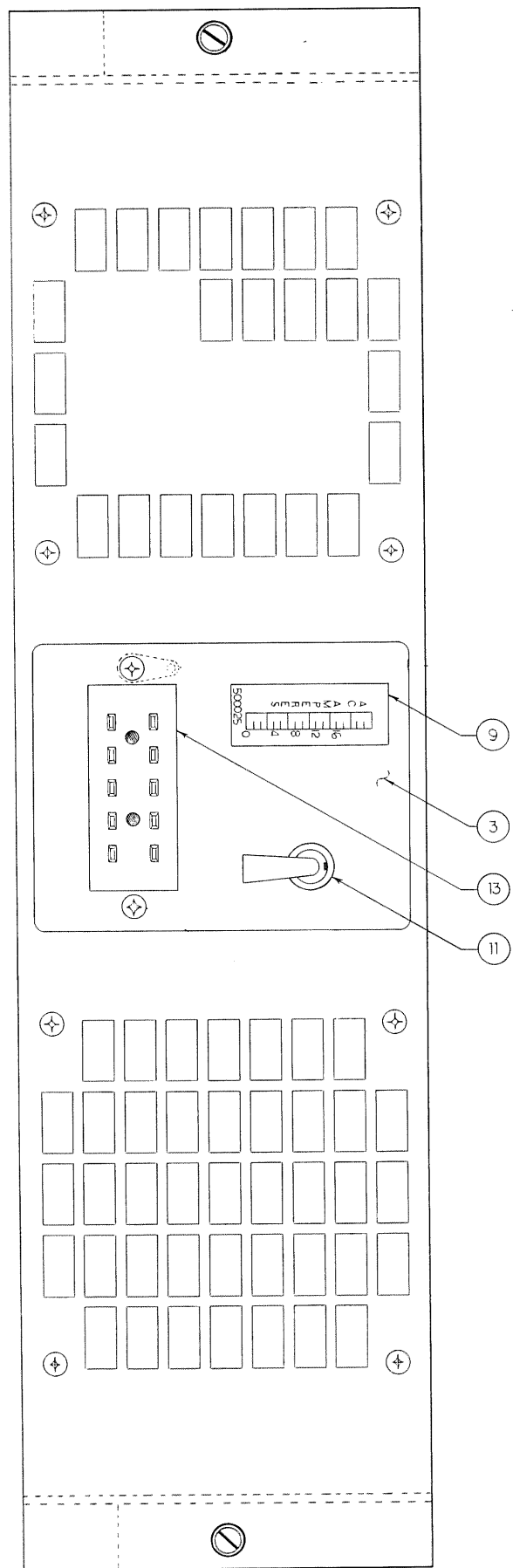

FIGURE 7-1
 MODEL 120-60
 CHASSIS ASSY DWG.

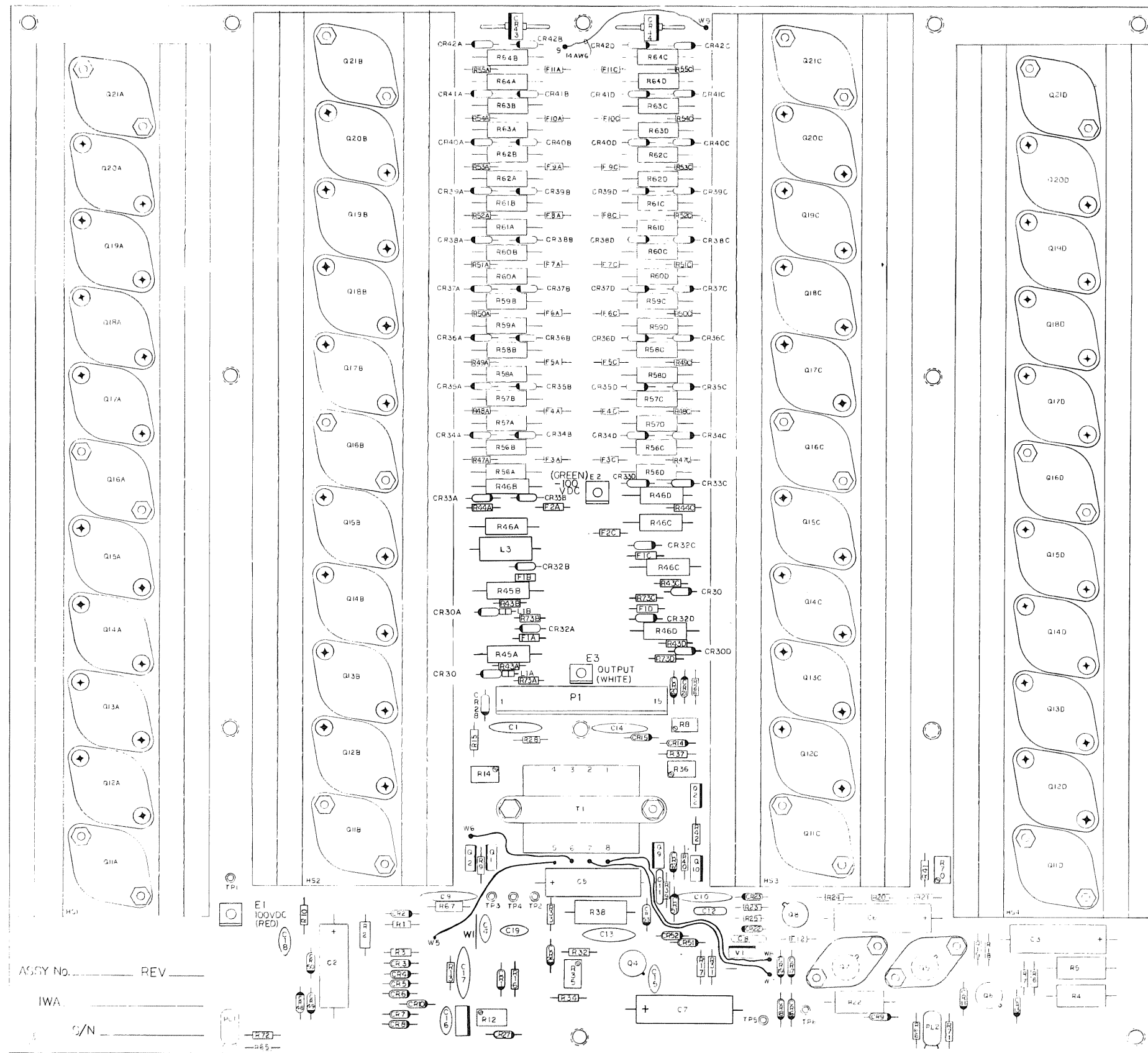

FIGURE 7-2
 MODEL 120-G0
 POWER AMPLIFIER ASSY DWG.

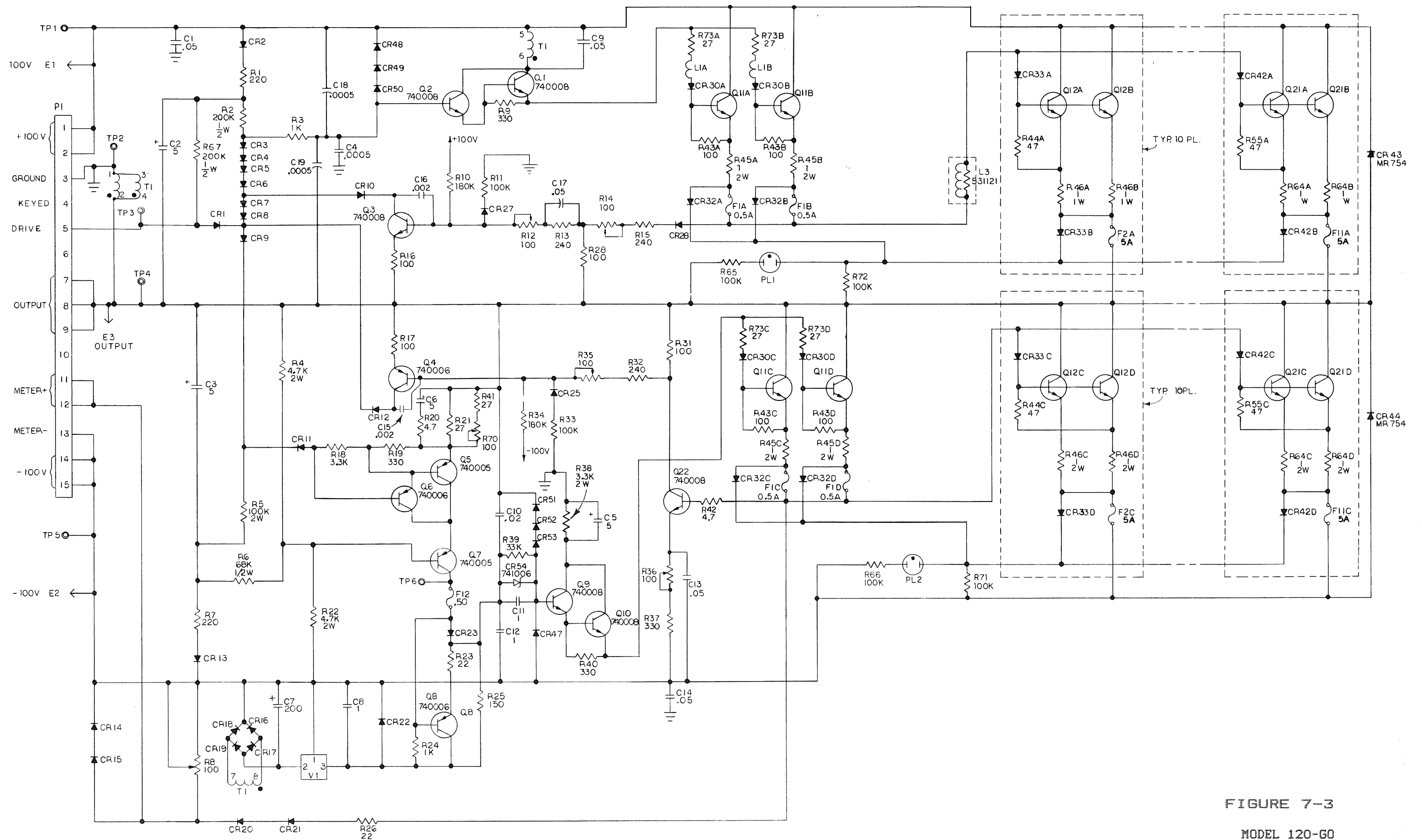

FIGURE 7-3
 MODEL 120-GO
 POWER AMPLIFIER SCHEMATIC

7.1.2 MODEL 120-60 POWER AMPLIFIER ASSY
MATERIAL LIST

Reference Figure 7-2 & Figure 7-3

CKT SYMBOL	DESCRIPTION	PPSC P/N
<u>DIODES</u>		
CR1 - CR23 CR25, CR27, CR28, CR30(A, B, C, D), CR32(A, B, C, D)- CR33(A, C)-CR42(A, C)	Diode, Silicon Rectifier 600 PIV 1A	741001
CR43, CR44	Diode, Silicon Rectifier 400 PIV 22A	741008
CR47-CR53	Diode, Silicon Rectifier 600 PIV 1A	741001
CR54	Diode, Zener 5.1V	741006
<u>TRANSISTORS</u>		
Q1, Q2, Q3	Transistor, NPN	740008
Q4	Transistor, PNP Approved Alternate Part:	740006 740018
Q5	Transistor, PNP Approved Alternate Part: Approved Alternate Part:	740005 740018 740019
Q6	Transistor, PNP Approved Alternate Part:	740006 740018
Q7	Transistor, PNP Approved Alternate Part: Approved Alternate Part:	740005 740018 740019
Q8	Transistor, PNP Approved Alternate Part:	740006 740018
Q9, Q10	Transistor, NPN	740008
Q11(A, B, C, D)- Q21(A, B, C, D)	Transistor, NPN Approved Alternate Part:	540130-5 540129-5
Q22	Transistor, NPN	740008

MODEL 390-G SECTION 7

CKT SYMBOL	DESCRIPTION	PPSC P/N
<u>CAPACITORS</u>		
C1	Capacitor, 0.05 uf @ 500 V	720023-50
C2, C3	Capacitor, 5.0 uf @ 300 V	720245-50
C4	Capacitor, 500 pf @ 1 KV	720011-50
C5, C6	Capacitor, 5.0 uf @ 300 V	720245-50
C7	Capacitor, 200 uf @ 50 V	720237-50
C8	Capacitor, 1.0 uf @ 50 V	720045-10
C9	Capacitor, 0.05 uf @ 500 V	720023-50
C10	Capacitor, 0.02 uf @ 1 KV	720013-20
C11, C12	Capacitor, 1.0 uf @ 50 V	720045-10
C13, C14	Capacitor, 0.05 uf @ 500 V	720023-50
C15 C16	Capacitor, 0.01 uf @ 1 KV	720013-10
C17	Capacitor, 0.05 uf @ 500 V	720023-50
C18, C19	Capacitor, 500 pf @ 1 KV	720011-50
<u>RESISTORS</u>		
R1	Resistor, 220 Ohm 1/4 W 5%	760021-22
R2	Resistor, 200K 1/2 W 5%	760034-20
R3	Resistor, 1.0K 1/4 W 5%	760022-10
R4	Resistor, 4.7K 2 W 5%	760052-47
R5	Resistor, 100K 2 W 5%	760054-10
R6	Resistor, 47K 1/2 W 5%	760043-47
R7	Resistor, 220 Ohm 1/4 W 5%	760021-22
R8	Trimpot, 100 Ohm	769990-004
R9	Resistor, 330 Ohm 1/4 W 5%	760021-33
R10	Resistor, 180K 1/4 W 5%	760024-18
R11	Resistor, 100K 1/4 W 5%	760024-10
R12	Trimpot, 100 Ohm	769990-004
R13	Resistor, 240 Ohm 1/4 W 5%	760021-24
R14	Trimpot, 100 Ohm	769990-004
R15	Resistor, 240 Ohm 1/4 W 5%	760021-24
R16, R17	Resistor, 100 Ohm 1/4 W 5%	760021-10
R18	Resistor, 3.3K 1/4 W 5%	760022-33
R19	Resistor, 330 Ohm 1/4 W 5%	760021-33
R20	Resistor, 4.7 Ohm 1/4 W 5%	760020-4R7

CKT SYMBOL	DESCRIPTION	PPSC P/N
<u>RESISTORS (con't)</u>		
R21	Resistor, 27 Ohm 1/4 W 5%	760020-27
R22	Resistor, 4.7K 1/4 W 5%	760052-47
R23	Resistor, 22 Ohm 1/4 W 5%	760020-22
R24	Resistor, 1.0K 1/4 W 5%	760022-10
R25	Resistor, 150 Ohm 1/4 W 5%	760021-15
R26	Resistor, 22 Ohm 1/4 W 5%	760020-22
R28, R31	Resistor, 100 Ohm 1/4 W 5%	760021-10
R32	Resistor, 240 Ohm 1/4 W 5%	760021-24
R33	Resistor, 100K 1/4 W 5%	760024-10
R34	Resistor, 180K 1/4 W 5%	760024-18
R35, 36	Trimpot, 100 Ohm	769990-004
R37	Resistor, 330 Ohm 1/4 W 5%	760021-33
R38	Resistor, 3.3K 2W 5%	760052-33
R39	Resistor, 100K 1/4 W 5%	760024-10
R40	Resistor, 330 Ohm 1/4 W 5%	760021-33
R41	Resistor, 27 Ohm 1/4 W 5%	760020-27
R42	Resistor, 4.7 Ohm 1/4 W 5%	760020-4R7
R43 (A, B, C, D)	Resistor, 100 Ohm 1/4 W 5%	760021-10
R44 (A, C)	Resistor, 47 Ohm 1/4 W 5%	760020-47
R45 (A, B, C, D), R46 (A, B, C, D)	Resistor, 1.0 Ohm 2 W 5%	760130-1R0
R47-55 (A, C)	Resistor, 47 Ohm 1/4 W 5%	760020-47
R56(A, B, C, D)- R64(A, B, C, D)	Resistor, 1 Ohm 2 W 5%	760130-1R0
R65, 66	Resistor, 100K 1/4 W 5%	760024-10
R67	Resistor, 200K 1/2 W 5%	760034-20
R68(B, D)	Resistor, 1 meg 1/4 W 5%	760025-10
R70	Trimpot, 100 Ohm	769990-004
R73(A, B, C, D)	Resistor, 27 Ohm 1/4 W 5%	760020-27
R74(B, D)-82(B, D)	Resistor, 1 meg 1/4 W 5%	760025-10
<u>FUSES</u>		
F1 (A, B, C, D)	Picofuse, 0.5 Amp @ 125VAC	712005
F2 (A, C)- F11 (A, C)	Picofuse, 5.0 Amp @ 125 VAC	712024
F12	Picofuse, 0.5 Amp 125 VAC	712005

MODEL 390-G SECTION 7

CKT SYMBOL	DESCRIPTION	PPSC P/N
<u>MISCELLANEOUS</u>		
PCB	120-G0 Printed Circuit Board	114060-D
L1 (A, B)	Ferrite Bead	702063
L3	Parasitic Suppressor	531121
T1	Transformer 30VCT	731003
V1	Voltage Regulator, - 5VDC	746004
PL1, PL2	Lamp, Neon	701005
HS1, HS2, HS3, HS4	Heatsink, Power Amplifier	105808-B
P1	Connector, 15 Pin Male	714011

7.2 THEORY OF OPERATION

The 120-GO is a linear power amplifier operating in the class B linear mode. Both power amplifier boards operate off ± 100 VDC and are capable of 62.5 VAC each. When driven 180° out of phase the output across the two amplifiers will be 125 VAC. Reference Figure 7-4 for a block diagram of the Model 120-GO. Figure 7.3 is the schematic of the PCB Assemblies.

The RED Amp is normally designated as the HI output vector. It naturally follows that the BLACK Amp is designated as the LO output vector. When the Module Output Switch is opened, the outputs of both amplifiers are disconnected from the system output bus. This is required when removing a power module from the system while energized.

Each amplifier can either source or sink current and has foldback current limit circuitry. This circuitry allows maximum current to be delivered into in-phase loads (P.F. = 1.0) and reduced current into reactive loads (P.F. < ± 0.7). Internal stresses and heating are held within safe limits by this configuration. Q3 is the positive current limit transistor. Q4 and Q22 are the negative current limit transistors.

CR1, CR8, CR11 and CR12 form the diode disconnect gate on the input of the 120-GO which prevents a front-end failure in the power module from loading down other modules in the system. Refer to figure 7-3.

CR34A and CR34C through CR42A and CR42C, F3A and F3C through F11A and F11C form the output transistor disconnect. Neon lights PL1 or PL2 will light when an output transistor has shorted.

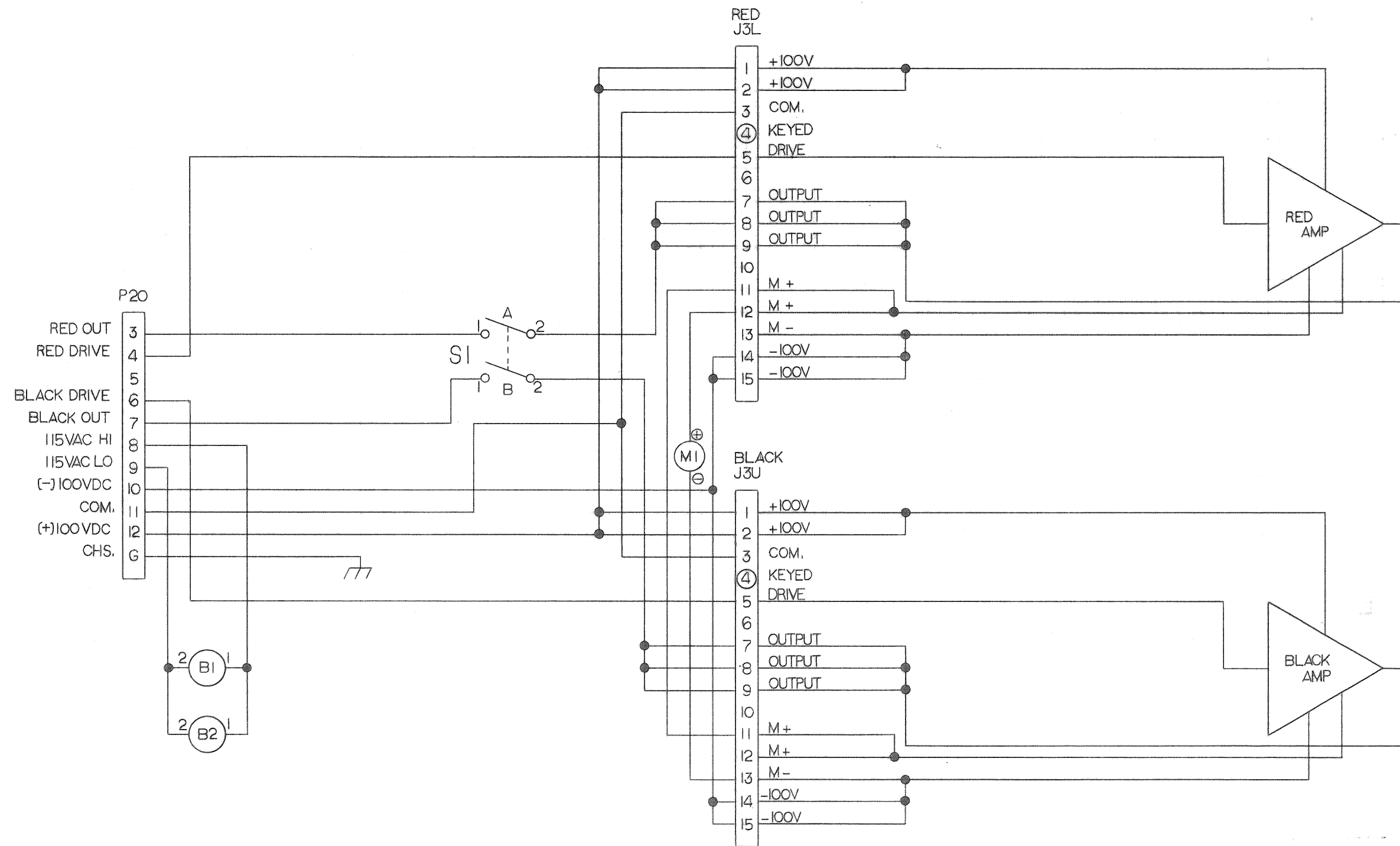

FIGURE 7-4

MODEL 120-60
BLOCK DIAGRAM

7.3 SERVICE

Pacific "G" Series equipment has been designed for repair by module exchange. Malfunctioning modules should be returned to the factory for repair. In applications which cannot tolerate any down-time, it is recommended that at least one module of each type be kept on hand as a spare for module recycling. The user will find that this is by far the best way to effect machine repairs. It is also, in the long run, the most economical method of maintenance.

The power module is designed to be serviced on the bench using only a standard VOM. Routine failures will result in a blown fuse; replacing the blown fuse and associated semi-conductor will usually restore the module to operation.

7.3.1 SAFETY NOTICES

* * * WARNING * * *

- * THIS EQUIPMENT CONTAINS HIGH ENERGY, LOW IMPEDANCE CIRCUITS !! LETHAL POTENTIALS ARE CONTAINED WITHIN THE SYSTEM.
- * CARE MUST BE EXERCISED WHEN SERVICING THIS EQUIPMENT IN ORDER TO PREVENT SERIOUS OPERATOR INJURY OR EQUIPMENT DAMAGE.
- * OBSERVE THE FOLLOWING WHEN SERVICE AND MAINTENANCE ARE REQUIRED:
 - 1) REMOVE ALL JEWELRY FROM ARMS AND NECKS WHEN SERVICING THIS EQUIPMENT. THIS PREVENTS THE POSSIBILITY OF SHORTING THROUGH THE JEWELRY AND CAUSING BURNS TO THE OPERATOR.
 - 2) DO NOT OPEN THE LOWER FRONT DOOR WITHOUT FIRST REMOVING THE INPUT SERVICE AND OPENING ALL CIRCUIT BREAKERS.
 - 3) SERVICE OTHER THAN CLEANING FILTERS OR REPLACING POWER MODULES SHOULD BE REFERRED TO PERSONNEL AUTHORIZED BY PACIFIC TO SERVICE THIS EQUIPMENT.

* * * * *

7.3.1 SAFETY NOTICES (con't)

- - - CAUTION - - -

R12, R14, R35 and R36 ADJUST THE FOLD BACK CURRENT LIMIT SETTING. R70 IS A FACTORY SET CONTROL WHICH DOES NOT REQUIRE ADJUSTMENT IN THE FIELD. ADJUSTMENT OF THESE CONTROLS BY ANYONE EXCEPT TECHNICIANS AUTHORIZED BY PACIFIC POWER SOURCE VOIDS THE WARRANTY.

IMPROPER ADJUSTMENT OF THESE CONTROLS WILL RESULT IN REDUCED POWER MODULE RELIABILITY!!!!

- - - - -

7.3.2 LOCATING A FAULTY POWER MODULE

A faulty Model 120-G0 is indicated by one of the following conditions:

- 1) "Service Required Lamps" are lit.
- 2) Module Output Ammeter reading significantly less than the ammeters on the other power modules. Significantly less is defined to be less than one-half the reading of the other power modules.

7.3.3 REMOVING THE POWER MODULE FROM THE SYSTEM

To remove the module from the system, perform the following:

- 1) Place the Module Output Switch in the OFF position.
- 2) Disconnect the power module from the mainframe harness.
- 3) Loosen the two captive fasteners located at the sides of the Power Module Front Panel.
- 4) Carefully slide the power module out of the mainframe. Be careful not to damage the mainframe harness as the module is being removed.

7.3.4 INSTALLING THE POWER MODULE INTO THE SYSTEM

To install the power module into the system, perform the following:

- 1) Carefully slide the power module into the mainframe.
Be careful not to damage the module mainframe harness as the module is being installed.
- 2) Tighten the two captive fasteners located at the sides of the Power Module Front Panel.
- 3) Place the Module Output Switch in the OFF position.
- 4) Connect the power module to the mainframe harness.
- 5) Place the Module Output Switch in the ON position.
Verify that the module is operating properly by monitoring the following:
 - a) No "Service Required Lamps" are lit.
 - b) Module Output Ammeter is reading approximately the same current as the other power modules.

7.3.5 FIELD SERVICE OF THE POWER MODULE

Field service to the Model 120-GO is limited to the following procedure:

- 1) Remove the module from the mainframe and remove the power module top cover screws. (qty. 10 each, located at the perimeter of the top cover.)
- 2) The cover can now be raised exposing the two power amplifiers. With an ohmmeter, check all of the picofuses on the boards (F1 - F11); mark any that read open. If F12 reads open, reassemble and return the module to the factory for repairs.
- 3) If any fuses read open, it will be necessary to remove the affected PCB assembly from the chassis. The open fuse and its associated transistor are to be replaced. The repaired PCB is then installed into the chassis. The connectors are keyed as a safety measure to prevent an error during reassembly.
- 4) Reassemble the module and replace it into the mainframe.

This is the extent of the repairs that are to be attempted in the field. If, after the above has been performed and the module in question does not operate properly, return it to Pacific Power Source for service.

The power modules are designed to be interchangeable into any power module location. Proper operation of a power module can be verified by installing it in a system and checking for full power capability and current sharing among other modules. Fault lights will indicate the location of failures within the module.

Pacific Power Source maintains a staff of highly trained technicians who are available to answer questions regarding the operation or servicing of this equipment. If any difficulty with regards to this equipment arises, the user is encouraged to call Pacific at (800) 854-2433, toll-free, outside CA., or (800) 472-8465, toll-free, inside CA., or (714) 898-2691, direct.

7.4 CALIBRATION

The calibration requirements of the Model 120-G0 Power Module consist of adjusting the Module Output Ammeter. This calibration is required to be performed at least once a year or when a power amplifier PCB assembly has been replaced.

To adjust the ammeter, first set R8 of the PCB mounted on the top cover to maximum resistance. Next, apply a 16 Amp load to the power module. Adjust R8 of the lower PCB until the ammeter reads 16 Amps \pm 0.5 Amps. Close the module and the calibration is complete.

- - - CAUTION - - -

R12, R14, R35 and R36 ADJUST THE FOLD BACK CURRENT LIMIT SETTING. R70 IS A FACTORY SET CONTROL WHICH DOES NOT REQUIRE ADJUSTMENT IN THE FIELD. ADJUSTMENT OF THESE CONTROLS BY ANYONE EXCEPT TECHNICIANS AUTHORIZED BY PACIFIC POWER SOURCE VOIDS THE WARRANTY.

IMPROPER ADJUSTMENT OF THESE CONTROLS WILL RESULT IN REDUCED POWER MODULE RELIABILITY!!!!

- - - - -

- THIS PAGE INTENTIONALLY LEFT BLANK -

SECTION 8

CONTROL MODULE DETAILED DESCRIPTION

TABLE OF CONTENTS

Para.	Title	Page
8.0	Control Module Detailed Description	8-1
8.1	Description	8-1
8.1.1	Control Module Chassis Material List	8-1
8.1.2	Voltage Amplifier Assembly Material List	8-4
8.1.3	Model 301-C Front Panel/Oscillator Material List	8-7
8.1.4	Model 301-H Front Panel/Oscillator Material List	8-11
8.1.5	Oscillator PCB Material List	8-15
8.2	Theory of Operation	8-18
8.3	Service	8-19
8.4	Calibration	8-21

LIST OF ILLUSTRATIONS

Fig.	Title	Page
8-1	Control Module Chassis Ass'y Dwg.	8-2
8-2	Control Module Chassis Schematic	8-3
8-3	Voltage Amplifier Ass'y Dwg.	8-5
8-4	Voltage Amplifier Schematic	8-6
8-5	301-C Front Panel Ass'y Dwg.	8-8
8-6	301-C Oscillator Schematic	8-9
8-7	301-H Front Panel Ass'y Dwg.	8-12
8-8	301-H Oscillator Schematic	8-13
8-9	Oscillator Card Ass'y Dwg.	8-16
8-10	System Block Diagram	8-17

8.0 CONTROL MODULE DETAILED DESCRIPTION

8.1 DESCRIPTION

The control module provides all the control functions for Pacific's G-Series power sources. It contains the local oscillator and controls, voltage amplifiers, on-off control, voltage metering, and is switch convertible to either single three phase output configurations. Refer To SECTION 5-4 for definition of the panel controls.

There are two models of control modules used in the G-Series. these are the Models 301-C and the 301-H. The Model 301-C is a variable frequency, variable voltage unit while the Model 301-H is a fixed frequency, variable voltage unit. The part number of the Model 301-C is 114100. The part number of the Model 301-H is 120000. When ordering spare modules be sure to order them by the appropriate number.

8.1.1 CONTROL MODULE CHASSIS MATERIAL LIST

Reference Figures 8-1 & 8-2.

ITEM	REF. #	DESCRIPTION	PPSC P/N
1		CHASSIS	114111-B
2		LABEL	114101-A
3		V. A. SUPPORT PLATE	111212-C
5	P-5	CONNECTOR 33 PIN	714029
9	B1	FAN	703104
11	J1, J2, J3, J4	CONNECTOR 15 PIN	714008
13		CONNECTOR PIN	714006
15		CONNECTOR KEY	714013
21	S1	ROTARY SWITCH, 10 POLE 5 POSITION	510022

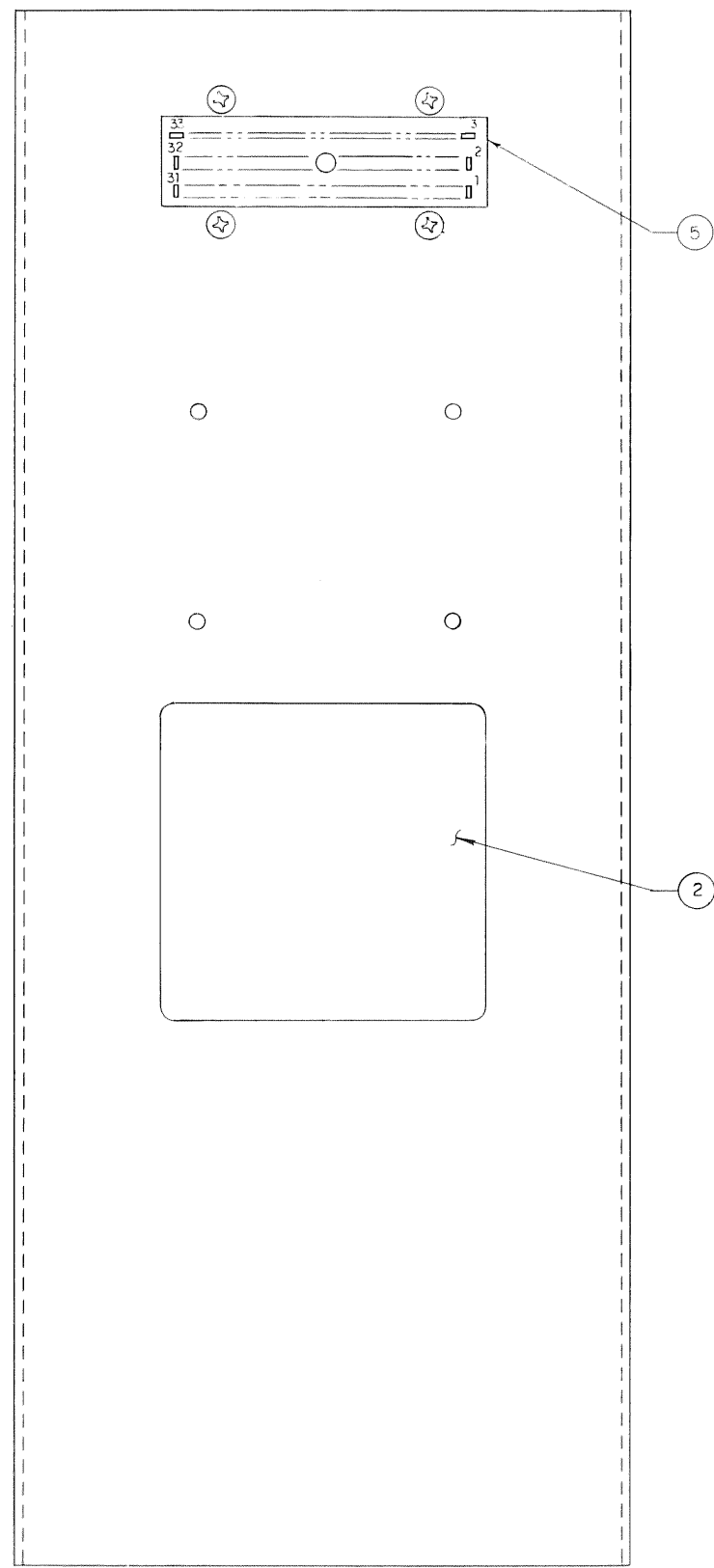

REAR PANEL

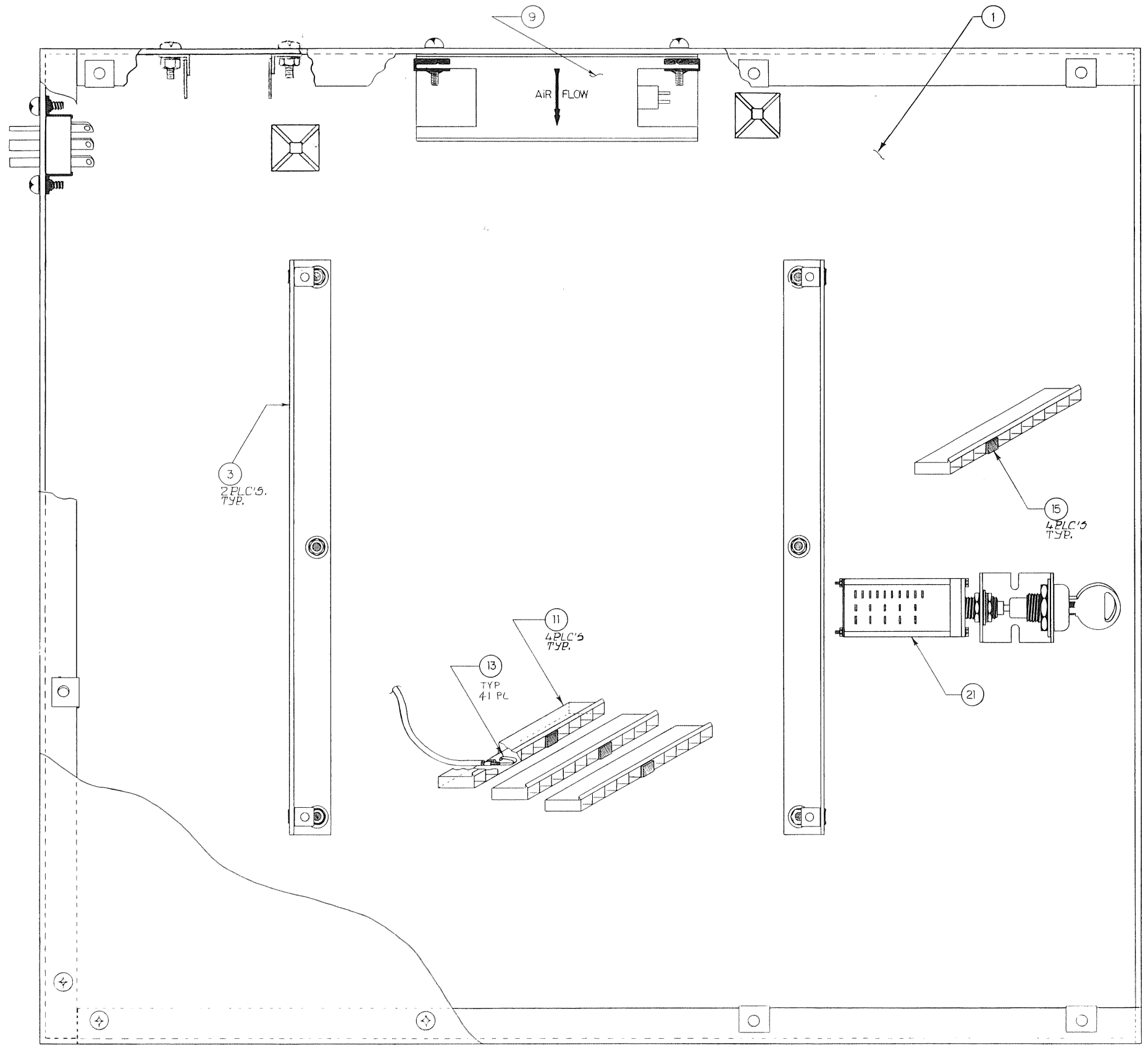

FRONT VIEW

FIGURE 8-1

CONTROL CHASSIS
CHASSIS ASSY DWG.

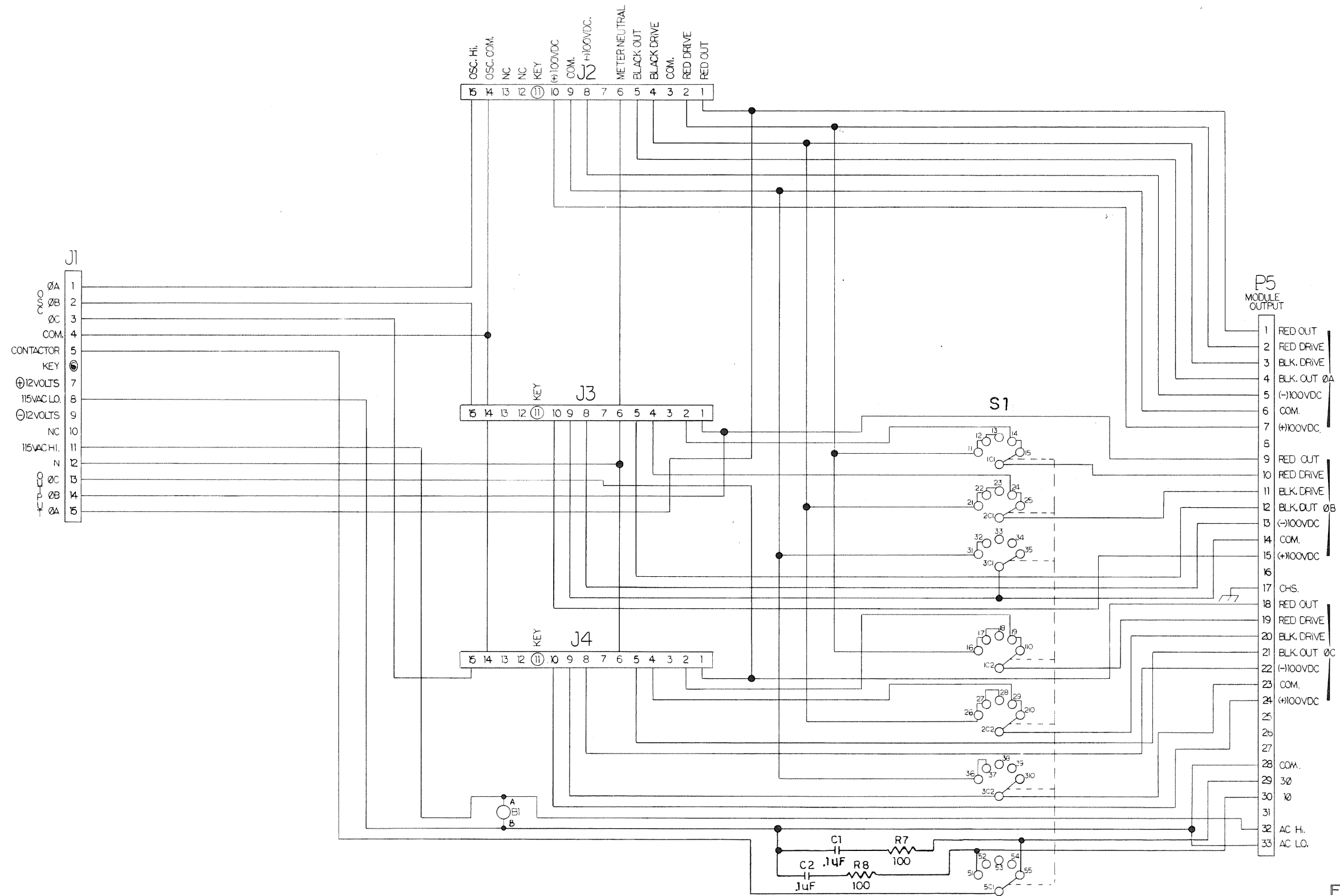

FIGURE 8-2

CONTROL CHASSIS
SCHEMATIC

MODEL 390-G SECTION 8

CKT SYMBOL	DESCRIPTION	PPSC P/N
<u>RESISTORS</u>		
R1, R2	RESISTOR, 130K 1/8W 1%	760213-130
R3-R6	RESISTOR, 5.11K 1/8W 1%	760211-511
R7, R8	RESISTOR, 130K 1/8W 1%	760213-130
R9, R10	RESISTOR, 22 MDG 1/4W 5%	760026-22
R11, R14	RESISTOR, 15K 2W 5%	760053-15
R15, R16	RESISTOR, 15K 1/2W 5%	760023-15
R17, R18	RESISTOR, 5.1K 1/4W 5%	760022-51
R19, R20	RESISTOR, 1.5K 1/4W 5%	760022-15
R21, R22	RESISTOR, 10K 2W 5%	760053-10
R23	RESISTOR, 22K 1/4W 5%	760023-22
R24	RESISTOR, 1K 1/4W 5%	760022-10
R25	RESISTOR, 22K 1/4W 5%	760023-22
R26	RESISTOR, 1K 1/4W 5%	760022-10
R27-R30	RESISTOR, 22 OHM 1/4W 5%	760020-22
R31, R32	RESISTOR, 4.7K 2W 5%	760052-47
R33	RESISTOR, 22 OHM 1/4W 5%	760020-22

MISCELLANEOUS

PCB	PRINTED CIRCUIT BOARD	114160-B
T1	TRANSFORMER, SIGNAL	731004
HS1, HS2	HEATSINK, FAN-TOP	703003
HS3-HS10	HEATSINK, FINGER	703004
P15	CONNECTOR, 15 PIN MALE	714011

MODEL 390-G SECTION 8

8.1.2 VOLTAGE AMPLIFIER ASSY
MATERIAL LIST

Reference Figures 8-3 & 8-4.

CKT SYMBOL	DESCRIPTION	PPSC P/N
<u>DIODES</u>		
CR1-CR4	DIODE, ZENER 15V 500 mW	741004
CR5-CR16	DIODE, 1 AMP 600 PIV	741001
<u>TRANSISTORS</u>		
Q1, 12	TRANSISTOR, PNP	746006
	ALTERNATE PART:	740010
	ALTERNATE PART:	740018
Q3-Q10	TRANSISTOR, NPN	540129-5
<u>INTEGRATED CIRCUITS</u>		
A1, A2	OPERATIONAL AMPLIFIER	746012
<u>CAPACITORS</u>		
C1, C2	CAPACITOR, 0.01uf 1000V	720013-10
C3, C4	CAPACITOR, 8uf 100V	720265-80
C5, C6, C7	CAPACITOR, 0.05uf 500V	720023-50
C8, C9	CAPACITOR, 8uf 100V	720265-80
C10	CAPACITOR, 0.05uf 500V	720023-50
C11, C12	CAPACITOR, 0.0033uf 400V	720132-33
C13, C14	CAPACITOR, 5uf 300V	720245-50
C15, C16	CAPACITOR, 0.01uf 1000V	720013-10

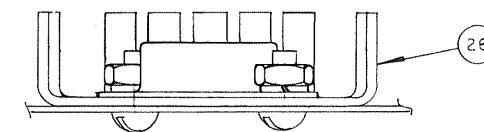
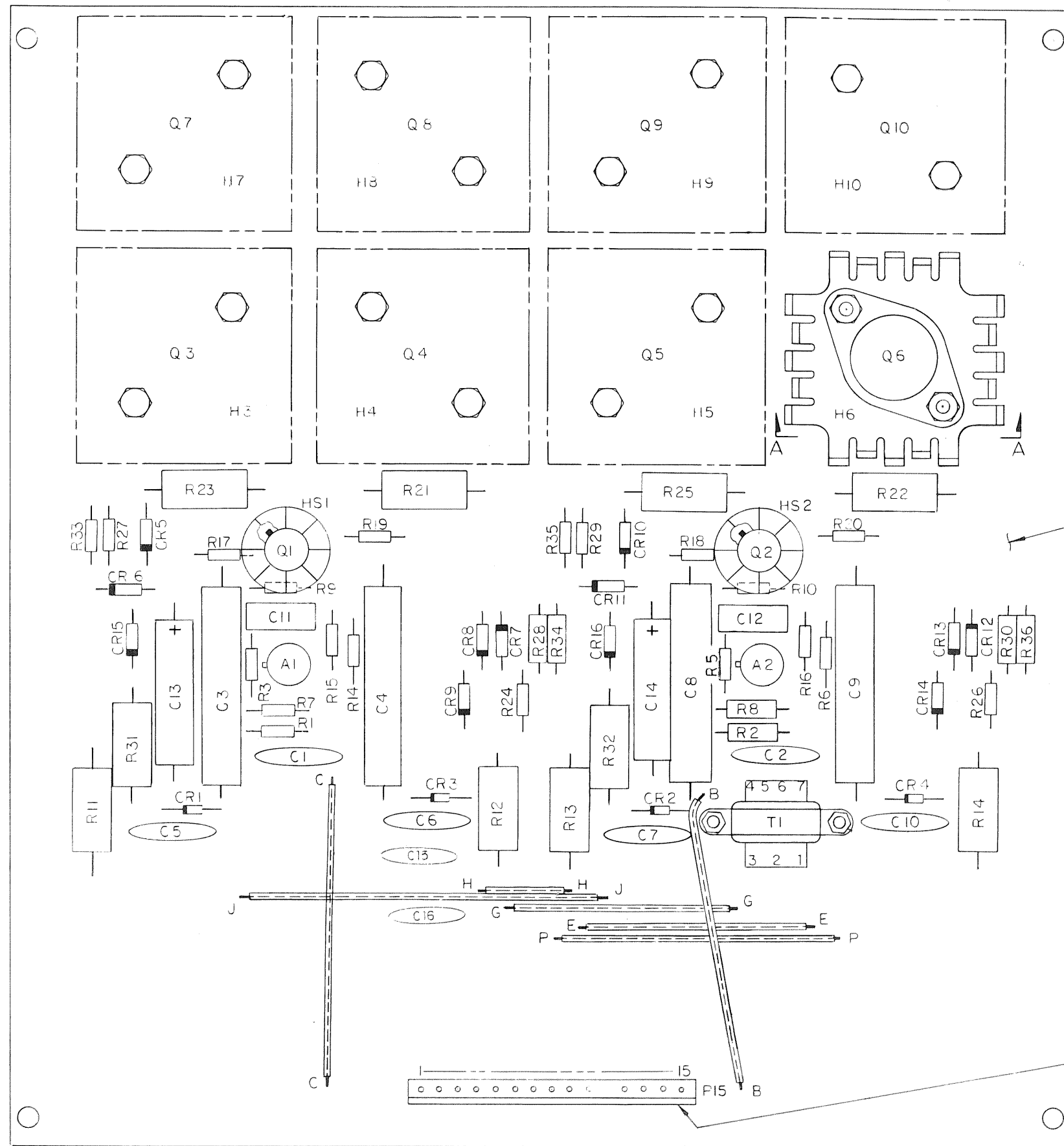

SECTION A-A
TYP 8 PLS

FIGURE 8-3
VOLTAGE AMPLIFIER
PCB ASSY DWG.

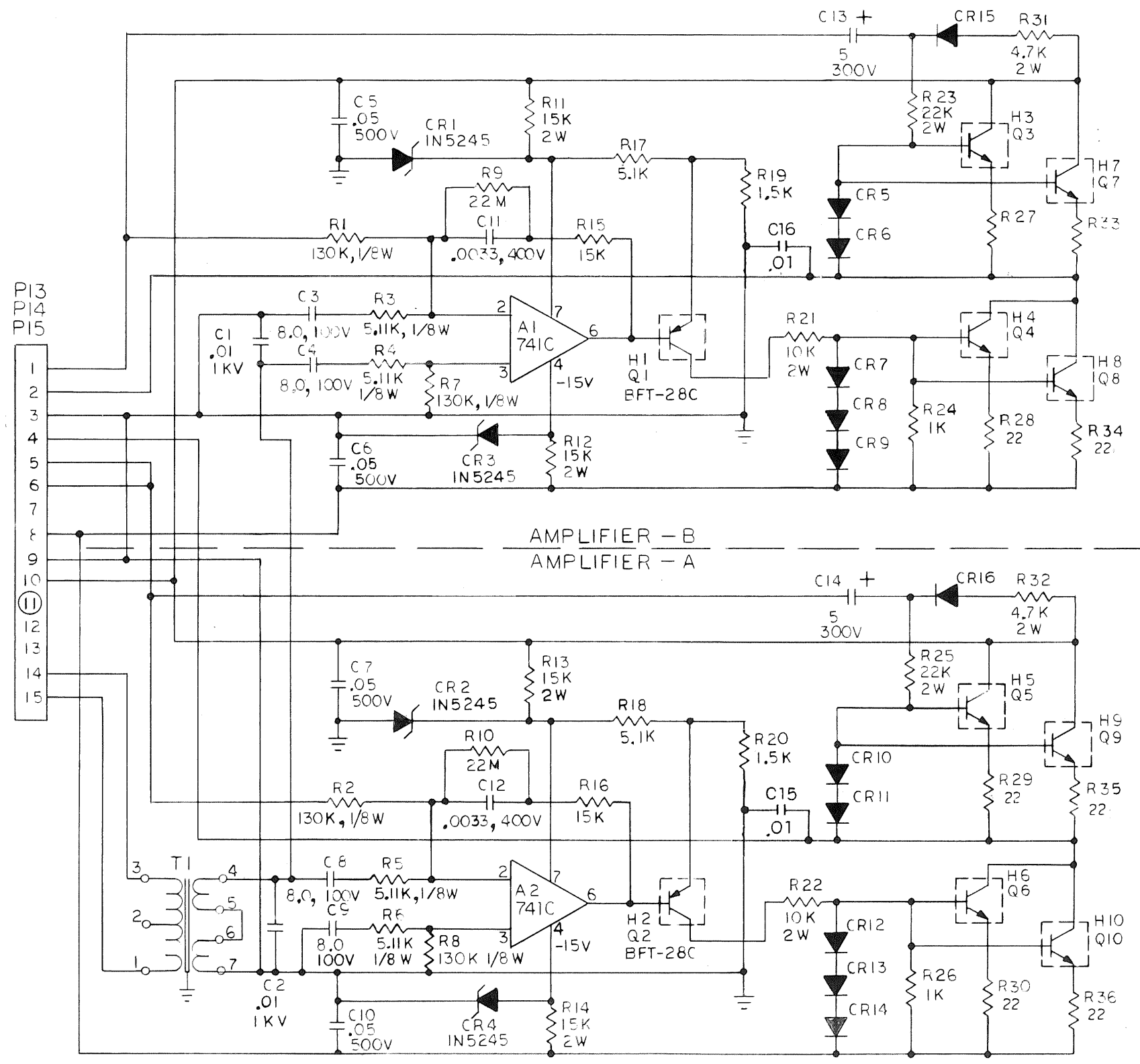

FIGURE 8-4

VOLTAGE AMPLIFIER
SCHEMATIC

MODEL 390-G SECTION 8

8.1.3 MODEL 301-C FRONT PANEL ASSEMBLY
MATERIAL LIST

Reference Figures 8-5 & 8-6.

ITEM	REF. #	DESCRIPTION	PPSC P/N
1		FRONT PANEL	111221-B
3		OSCILLATOR CARD ASSY.	111270-B
5		BRACKET, POTENTIOMETER	108802
7	R10	POTENTIOMETER 20K 3-GANG	769990-011
9		DIAL DRIVE	703006
11		DIAL DRIVE	100112-A
13		FREQUENCY INDICATOR	702012
15	S3	SWITCH, OUTPUT POWER	510008
17	M1	METER, WITH BEZEL	500011
19	S1	SWITCH, OSCILLATOR	520018
20		SWITCH, BRACKET	120022
23	S2	SWITCH	510019
27	J1-J3	CONNECTOR, BNC	714015
31	J1-J3	KNOB AMPLITUDE	702034
33		KNOB OSCILLATOR	702035
35		HANDLE	702047
37		FERRULE	702048
39		LAMP	701004

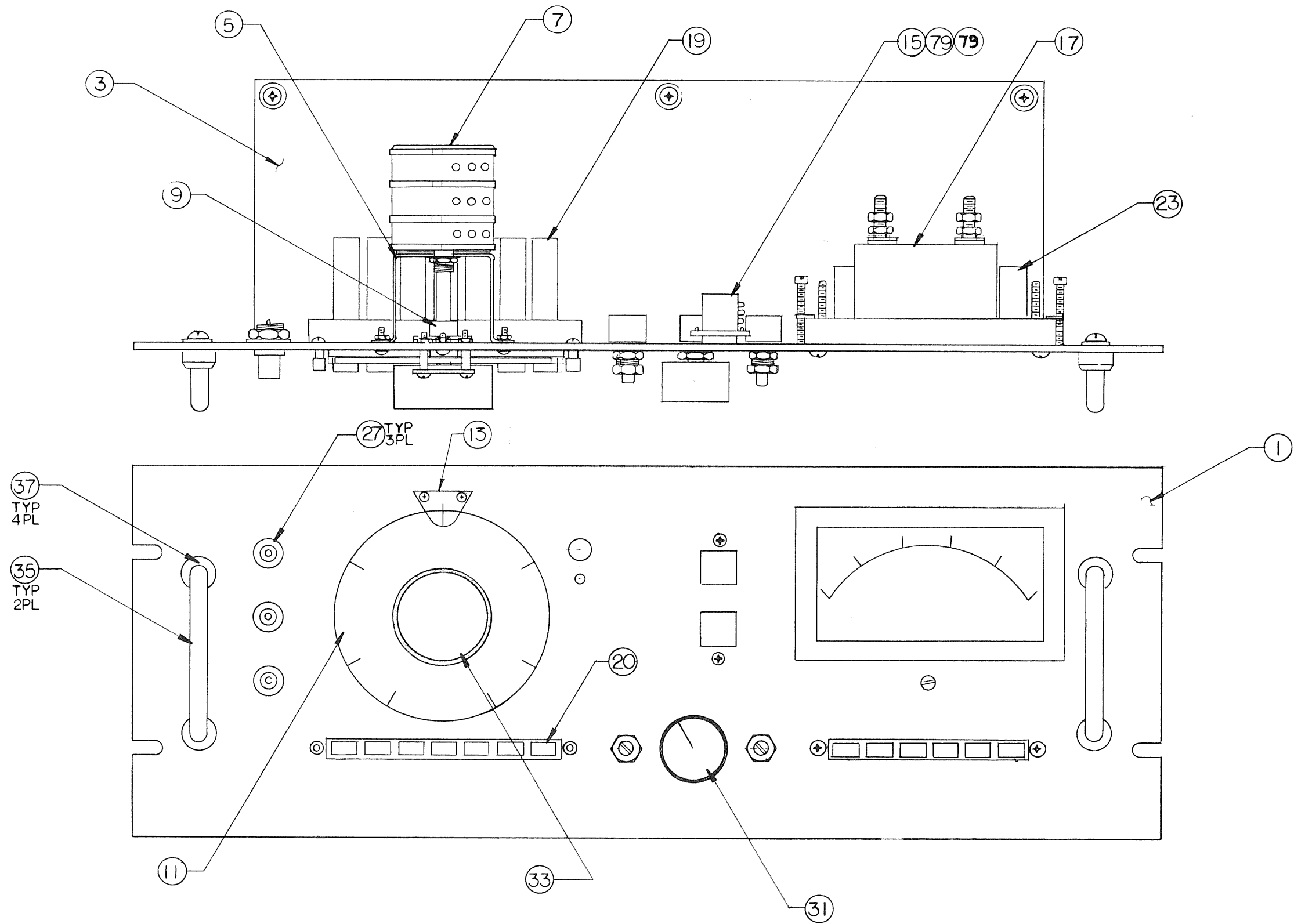

FIGURE 8-5
 MODEL 301-C FRONT PANEL/OSC.
 ASSY DWG.

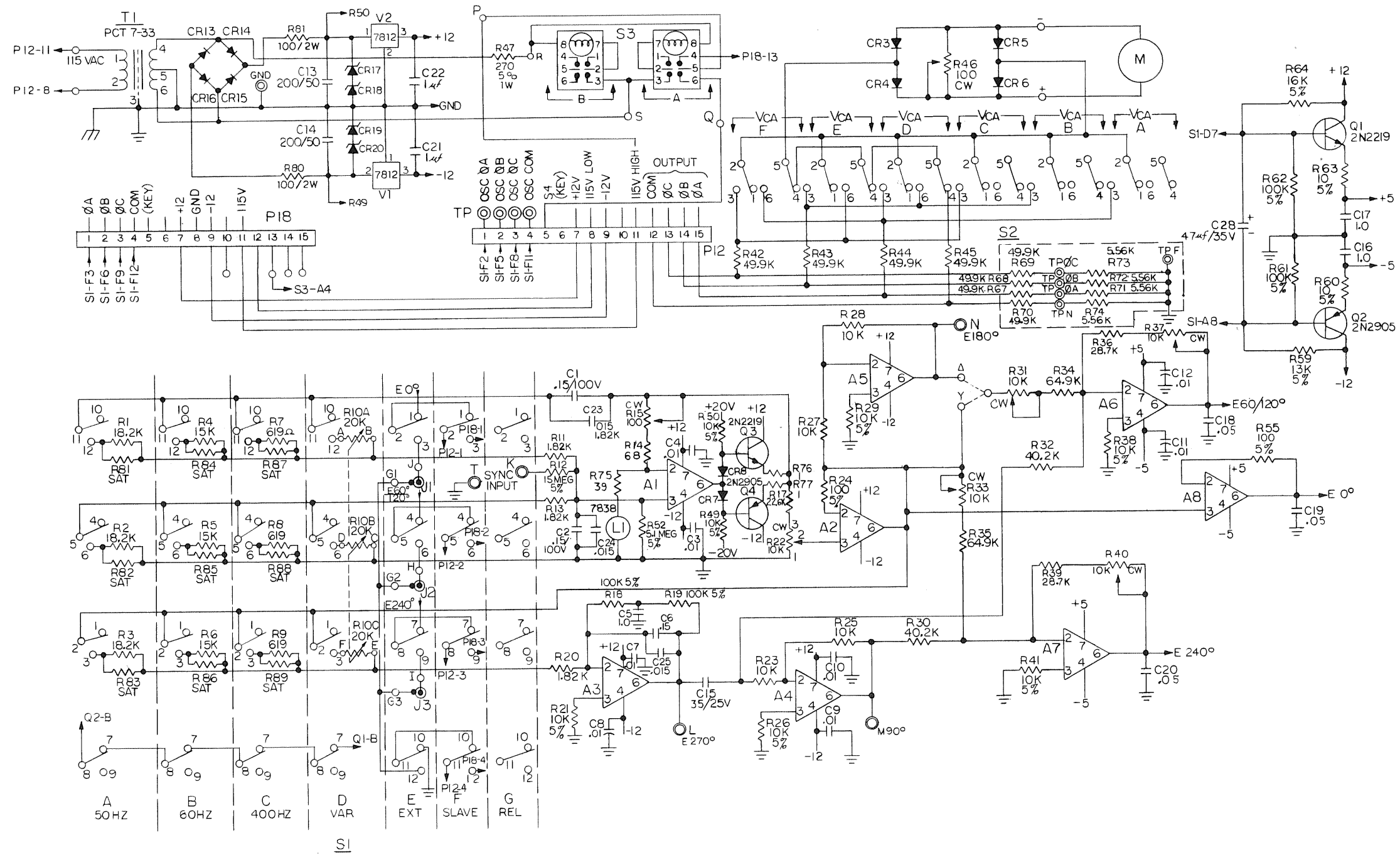

FIGURE 8-6

MODEL 301-C FRONT PANEL/OSC.
SCHEMATIC

- THIS PAGE INTENTIONALLY LEFT BLANK -

8.1.4 MODEL 301-H FRONT PANEL ASSEMBLY
MATERIAL LIST

Reference Figures 8-7 & 8-8.

ITEM	REF. #	DESCRIPTION	PPSC P/N
1		FRONT PANEL	120021
3		OSCILLATOR PCB ASSEMBLY	111270-C
15	S3	OUTPUT POWER SWITCH	510008
17	M1	METER, WITH BEZEL	500011
23	S2	SWITCH	510019
31		KNOB AMPLITUDE	702034
35		HANDLE	702047
37		FERRULE	702048

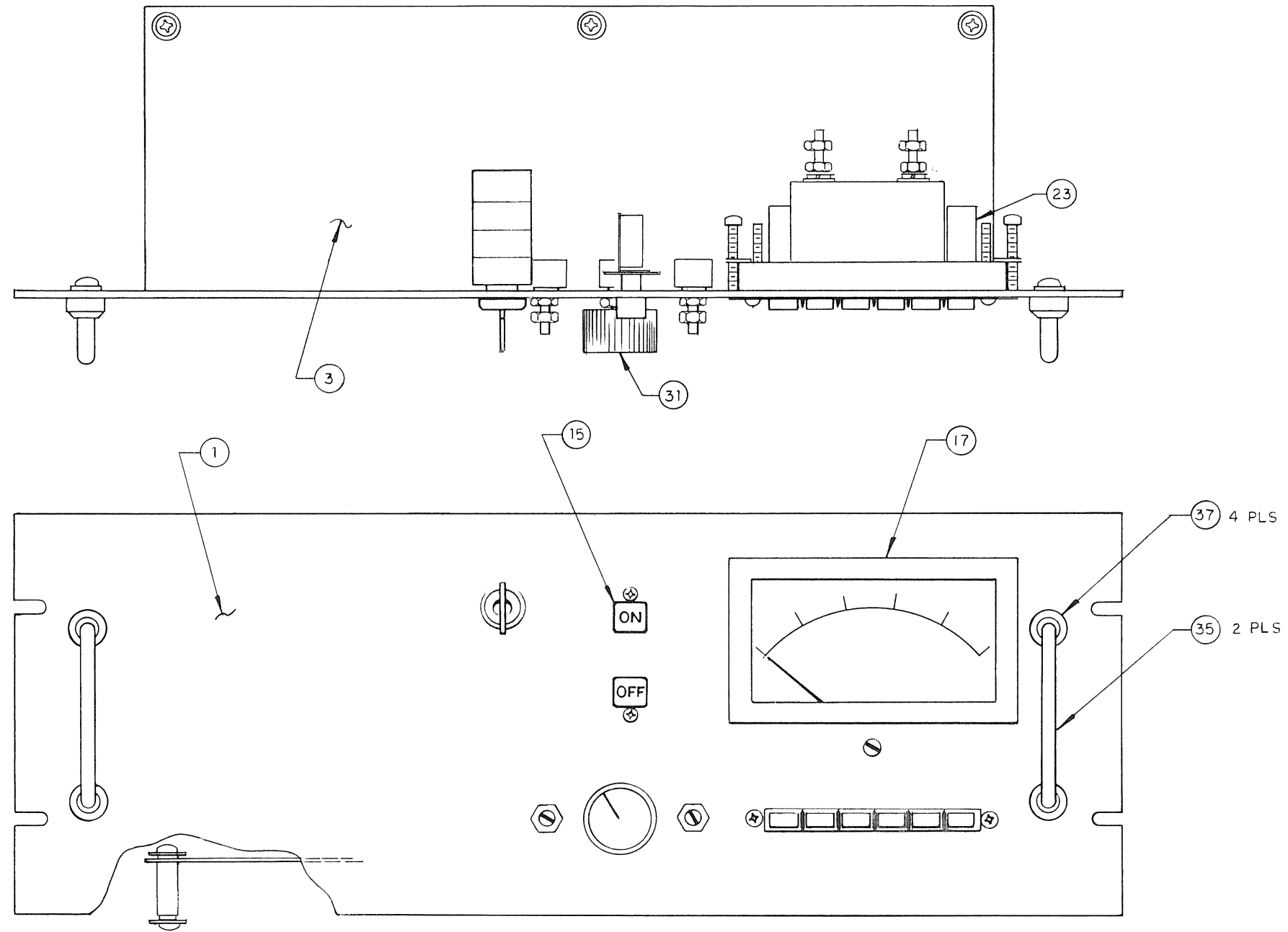

FIGURE 8-7
 MODEL 301-H FRONT PANEL/OSC.
 ASSY DWG.

MODEL 390-G SECTION 8

8.1.5 OSCILLATOR ASSEMBLY
MATERIAL LIST

Reference Figures 8-9 & 8-6 or 8-8

CKT SYMBOL	DESCRIPTION	PPSC P/N
<u>DIODES</u>		
CR3-CR8, CR13-CR16	DIODE, 1 AMP 600 PIV	741001
CR17-20	DIODE, ZENER 12.0V 5.0W	741010
<u>TRANSISTORS</u>		
Q1	TRANSISTOR, NPN	740001
Q2	TRANSISTOR, PNP	740002
Q3	TRANSISTOR, NPN	740001
Q4	TRANSISTOR, PNP	740002
<u>INTEGRATED CIRCUITS</u>		
A1 - A8	OPERATIONAL AMPLIFIER	746012
V1	VOLTAGE REGULATOR, - 12 VDC	746005
V2	VOLTAGE REGULATOR, + 12 VDC	746003
<u>CAPACITORS</u>		
C1, C2	CAPACITOR, 0.15 uF 200V	720084-15
C3, C4	CAPACITOR, 0.01 uF 1000V	720013-10
C5	CAPACITOR, 1 uF 50V	720045-10
C6	CAPACITOR, 0.15 uF 200V	720084-15
C7 - C12	CAPACITOR, 0.01 uF 1000V	720013-10
C13, C14	CAPACITOR, 200 uF 50V	720237-20
C15	CAPACITOR, 35 uF 25V	720346-35
C16, C17	CAPACITOR, UuF 50V	720045-10
C18, C19, C20	CAPACITOR, 0.05 uF 500V	720023-50
C21, C22	CAPACITOR, 1 uF 50V	720045-10
C23, C24, C25	CAPACITOR, 0.015 uF 200V	720083-15
C28	CAPACITOR, 47 uF 35V	720336-47
<u>RESISTOR</u>		
R1, R2, R3	RESISTOR, 18.2 K 1/8W 1%	760212-182
R4, R5, R6	RESISTOR, 15.0 K 1/8W 1%	760212-150
R7, R8, R9	RESISTOR, 619 OHM 1/8W 1%	760210-619
R11	RESISTOR, 1.82 K 1/8W 1%	760211-182
R12	RESISTOR, 15 MEG 1/8W 1%	760026-15
R13	RESISTOR, 1.82 K 1/8W 1%	760211-182
R14	RESISTOR, 68 OHM 1/8W 1%	760210-68
R15	TRIMPOT, 100 OHM	769990-004
R17	RESISTOR, 22.6 K 1/8W 1%	760212-226
R18, R19	RESISTOR, 100 K 1/4W 5%	760024-10
R20	RESISTOR, 1.82 K 1/8W 1%	760211-182
R21	RESISTOR, 10K 1/4W 5%	760023-10
R22	POTENTIOMETER, 10 K	769990-008
R23	RESISTOR, 10 K 1/8W 1%	760212-100
R24	RESISTOR, 100 OHM 1/4W 5%	760021-10
R25	RESISTOR, 10 K 1/8W 1%	760212-100
R26	RESISTOR, 10 K 1/4W 5%	760023-10
R27, R28	RESISTOR, 10 K 1/8W 1%	760212-100
R29	RESISTOR, 10 K 1/4W 5%	760023-10
R30	RESISTOR, 40.2 k 1/8w 1%	760212-402

RESISTORS (con't)

R31		TRIMPOT, 10K	769990-006
R32		RESISTOR, 40.2 K 1/8W 1%	760212-402
R33		TRIMPOT, 10 K	769990-006
R34, R35		RESISTOR, 64.9 K 1/8W 1%	760212-649
R36		RESISTOR, 28.7 K 1/8W 1%	760212-287
R37		POTENTIOMETER, 10 K	769990-008
R38		RESISTOR, 10 K 1/4W 5%	760023-10
R39		RESISTOR, 28.7 K 1/8W 1%	760212-287
R40		POTENTIOMETER, 10 K	769990-008
R41		RESISTOR, 10 K 1/4W 5%	760023-10
R42 - R45		RESISTOR, 49.9 K 1/8W 1%	760212-499
R46		TRIMPOT, 100 OHM	769990-004
R47		RESISTOR, 270 OHM 1W 5%	760041-27
R49, R50		RESISTOR, 10 K 1/4W 5%	760023-10
R52		RESISTOR, 5.1 MEG 1/4W 5%	760025-51
R55		RESISTOR, 100 OHM 1/4W 5%	760021-10
R59		RESISTOR, 13 K 1/4W 5%	760023-13
R60		RESISTOR, 10 OHM 1/4W 5%	760020-10
R61, R62		RESISTOR, 100K 1/4W 5%	760024-10
R63		RESISTOR, 10 OHM 1/4W 5%	760020-10
R64		RESISTOR, 16 K 1/4W 5%	760023-16
R66		RESISTOR, 49.9 K 1/2W 5%	760332-499
R71 - R74		RESISTOR, 5.56 K 1/8W 1%	760211-556
R75		RESISTOR, 39 OHM 1/8W 1%	760210-39
R76		RESISTOR, 1 OHM 1/4W 5%	760020-1R0
R80, 81		RESISTOR, 100 OHM 2W 5%	760051-10

MISCELLANEOUS

L1		OSCILLATOR PRINTED CIRCUIT BRD	111260-B
T1		LAMP	701003
P12, P18		TRANSFORMER, POWER SUPPLY	731002
		CONNECTOR, 15 PIN MALE	714011

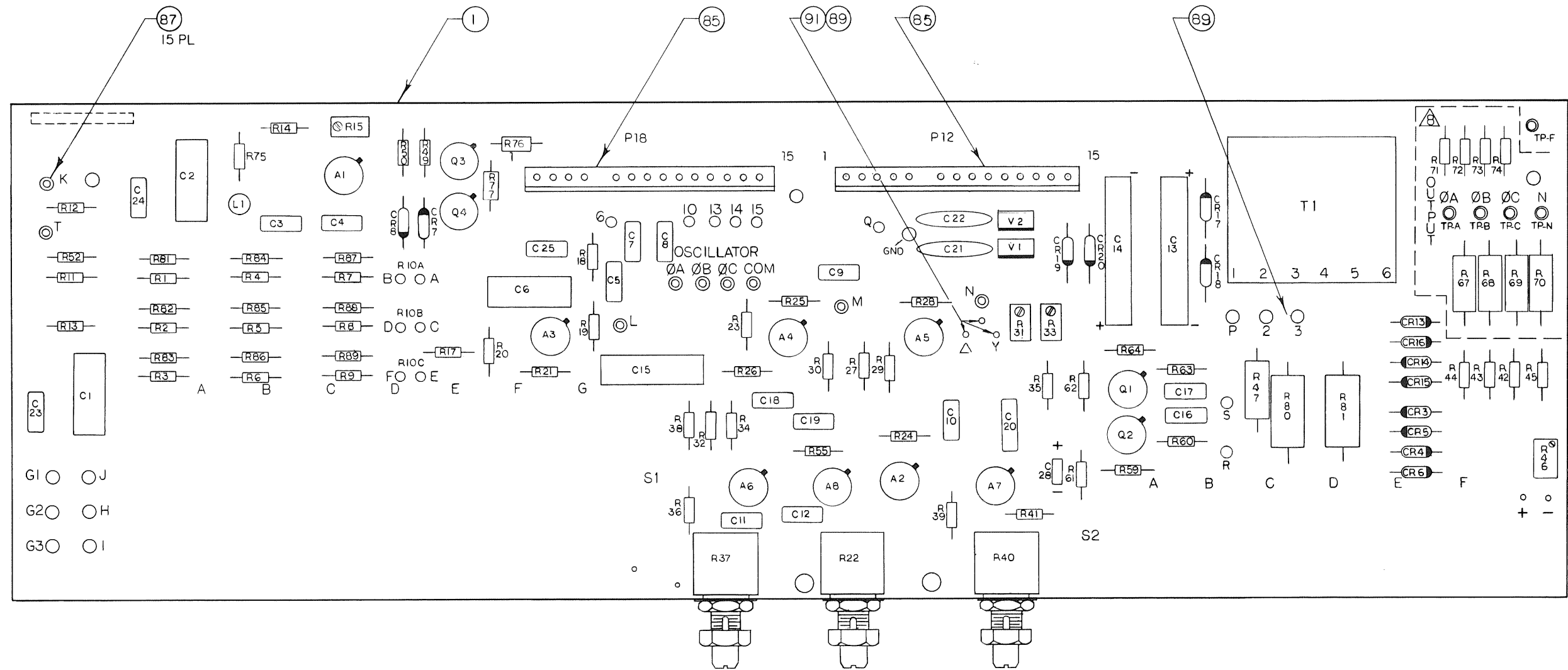

FIGURE 8-9

OSCILLATOR PCB
ASSY DWG.

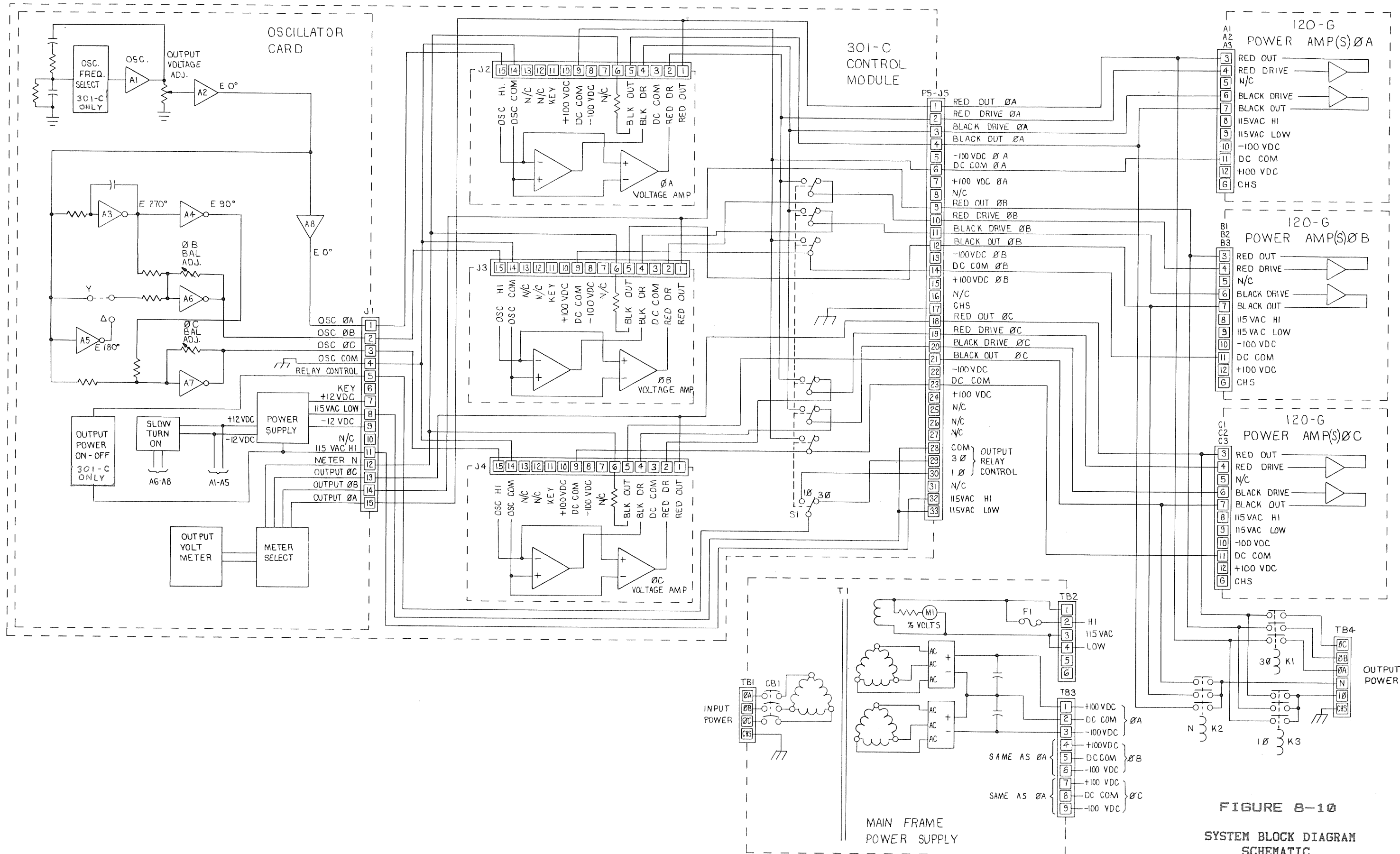

FIGURE 8-10
SYSTEM BLOCK DIAGRAM
SCHEMATIC

8.2 THEORY OF OPERATION

For a block diagram of the complete system, reference Figure 8-10.

The oscillator is a wien-bridge type with amplitude stabilization provided by a miniature light bulb. The oscillator signal is divided by the front panel voltage control R22 and buffered by amplifier A2. The three phase signals are generated by vector summations of in-phase and quadrature signals. The 0 degree and 180 degrees signals are present at the outputs of amplifiers A2 and A5. The intergrator, A3, produces the 270 degree vector which is inverted by A4 to form the 90 degree vector. The signals are algebraically added by A6 and A7 to form the desired phase shifts; a jumper selects for either 60 or 120 degree phase shifts for DELTA or WYE output. Trimpots R31 and R33 adjust the 60/120 and 240 degrees phase shifts, respectively. Refer to Figures 8-6 and 8-8.

The voltage amplifier is a class A type amplifier. It isolates and amplifies the low level oscillator signal. It is a closed loop amplifier which derives its feedback from the output of the power amplifiers, There are 2 amplifiers, each with a voltage gain of 25, per PCB assembly. Each produces 60 VRMS each and are operated 180 degrees out of phase so that an effective 120 VRMS is across the VA outputs. A fixed current source, Q3, Q5, Q7 and Q9, provides positive drive; while Q4, Q6, Q8 and Q10 provide the negative drive. Refer to figure 8-2.

8.3 SERVICE

Pacific "G" Series equipment has been designed for repair by module exchange. Malfunctioning modules should be returned to the factory for repair. In applications which cannot tolerate down-time, it is recommended that at least one module of each type be kept on hand as spares for module recycling.

The user will find that this is by far the best way to effect machine repairs. It is also, in the long run, the most economical method of maintenance.

The control module can be removed from the front by removing the four front panel screws and disconnecting the rear panel connector. The control module can also be accessed in the machine by removing the top cover of the main frame and the top cover of the control module.

- - - C A U T I O N - - -

WHEN SERVICING IN THE SYSTEM, DO NOT GROUND ANY
DC COMMONS AS THEY ARE FLOATING AND DAMAGE MAY RESULT.

- - - - -
If the oscillator is suspect, monitor the outputs. They should be clean sinewaves at the selected frequency at a voltage of 1 - 2 VRMS.

If the voltage amplifier is suspect, simply switch it with another voltage amplifier.

- THIS PAGE INTENTIONALLY LEFT BLANK -

8.4 CALIBRATION PROCEDURE

Pacific recommends calibration checks of the control module once every six months or when the module has been repaired. The following procedure is to be used to verify proper operation of the control module.

* * * W A R N I N G * * *

* WHEN SERVICING IN THE SYSTEM, DO NOT GROUND ANY DC COMMONS AS THEY ARE FLOATING AND DAMAGE MAY RESULT.

* LETHAL VOLTAGES ARE PRESENT WITHIN THE CONTROL MODULE.

* * * * *

8.4.1 DC OFFSET TEST

Turn unit on, turn output voltage to zero, the 1 Phase/3 Phase switch to 3 Phase, the output power switch on, then using a long averaging time DVM verify that the DC voltage from each three phase output to neutral is less than 10 millivolts DC.

8.4.2 SLOW TURN ON TEST

Turn up output until 120 VAC is reached on all three phases. Using an oscilloscope observe each output to verify a clean sinewave. Push the oscillator mode release button and select 50 Hz. Verify slow turn on of 0.5-1 second before full voltage is reached. Repeat with 60 Hz, 400 Hz and VAR buttons. The slow turn on circuit consists of R59, R64, C28 and associated circuitry. See figure 8-8.

8.4.3 FREQUENCY CALIBRATION PROCEDURE

Verify all fixed and variable frequencies.

50 Hz position:	50 Hz + 0.125 Hz
60 Hz position:	60 Hz + 0.150 Hz
400 Hz position:	400 Hz + 1.00 Hz
VAR 50 Hz position:	50 Hz + 1.0 Hz
VAR 60 Hz position:	60 Hz + 1.2 Hz
VAR 400 Hz position:	400 Hz + 8.0 Hz

NOTE: When calibrating the Model 301-H only the nominal output frequency is verified to be within $\pm 0.25\%$.

Change the values of R81 - R89 for fixed adjustment and move the dial for variable frequency adjustment.

8.4.4 VOLTMETER CALIBRATION PROCEDURE

Using a DVM, set the output 120 VRMS on all phase and verify Phase A, B, C voltmeter readings to be 120 ± 2.0 VRMS. The voltmeter may be adjusted by R46.

8.4.5 PHASE SEPARATION ADJUSTMENT PROCEDURE

Verify phase separation of $120 \pm 1^\circ$ between all three phases. This can be done with a phase meter or a DVM. With a DVM, set each output to 100 ± 0.1 VRMS and verify phase to phase voltages to be 173.2 ± 1.0 VRMS. Adjust R31 and R33 for proper phase separation.

- THIS PAGE INTENTIONALLY LEFT BLANK -

SECTION 9
TRANSFORMER OUTPUTS
and
MODIFICATIONS
TABLE OF CONTENTS

Para.	Title	Page
9.1	Transformer Outputs	9-1
9.2	Modifications	9-3

9.1 TRANSFORMER OUTPUTS

If so equipped, the following pages will contain information regarding output transformer configurations which have been installed into the system. When consulting the factory regarding these secondary outputs, be prepared to supply the magnetics code. This is a six digit number beginning with a "5" and is imprinted on the system ID label on the rear of the mainframe.

- THIS PAGE INTENTIONALLY LEFT BLANK -

9.2 MODIFICATIONS

If so equipped, the following pages will contain data regarding engineering modifications which have been installed into the system. When consulting the factory with respect to the modification, be prepared to supply the modification number. This is a four digit number suffix of the model number and is imprinted on the system ID label attached to rear of the mainframe. For example, the modification number for the Model 390-GC/5830 is 5830.

G-SERIES
MULTI-CABINET PARALLEL OPERATION PROCEDURE

Prepared and Submitted
by
Pacific Power Source Inc.
17692 FITCH
IRVINE, CA 92614

PPSC Dwg. No. : 109570

TECHNICAL MEMO
TM—0065

March 6, 1990

G-SERIES

MULTI-CABINET PARALLEL OPERATION PROCEDURE

TABLE OF CONTENTS

1.0	CHARACTERISTICS OF MULTI-CABINET G-SERIES SYSTEMS . . .	1
2.0	INSTALLATION OF MULTI-CABINET PLC	3
2.1	EQUIPMENT LAYOUT AND CABLING	3
2.2	INSTALLATION AND START-UP	4
3.0	OPERATION AND SERVICE OF MULTI-CABINET PLC	8
3.1	SYSTEM ON-OFF CONTROL	8
3.2	SYSTEM MAINTENANCE	9
3.2.1	ROUTINE OBSERVATIONS	9
3.2.2	POWER MODULE EXCHANGE	10
3.2.3	SLAVE CABINET SHUTDOWN	11
3.2.4	MASTER CABINET SERVICE	11

1.0 CHARACTERISTICS OF MULTI-CABINET G-SERIES SYSTEMS

G-Series power sources (PLC) have been designed to operate as single cabinet or multi-cabinet parallel systems. When operated singly, each cabinet has a self-contained input circuit breaker and an output contactor for load power control. Also, each cabinet has its own control module to supply drive signals to its power modules.

When operated in parallel, one cabinet is designated MASTER and all other cabinets are designated SLAVES. This is done by disconnecting all SLAVE cabinet control modules and the addition of a signal cable from the MASTER control module to all SLAVE cabinets (Refer to Figure 1). In effect the MASTER cabinet control module drives all SLAVE cabinets. The control module in each SLAVE cabinet has no function, except for cabinet tests and repairs, and for possible reversion to single cabinet or MASTER operation.

Further, when multiple cabinets are in parallel, system output ON-OFF control must be either from the MASTER cabinet or, preferably, from a single output circuit breaker.

Because cabinets are tied together in so many places (input power, output power and signal cable) individual cabinets cannot be disconnected from the power grid by simply turning off cabinet input-output contactors. Special procedures are required.

From time to time it may be necessary to disconnect a cabinet from the power grid completely for maintenance purposes. It may also be necessary to reassign the MASTER cabinet function. All of these operations are feasible, but require careful adherence to the procedures which follow. The figure opposite is a rear view of a typical three cabinet installation. Normally, in single cabinet operation, harness connector J5 would plug into control module connector P5. The special paralleling cable connects J5 to P1 and J1 to P5 which only drives P5 but also provides a second connector P2 which drives J5 of a SLAVE cabinet. A second paralleling cable provides another P2 for the second SLAVE cabinet, and so forth.

Four and five cabinet systems are connected in a similar manner. This is accomplished by appending the fourth and fifth SLAVE cabinets in the same way that the third is appended to the second.

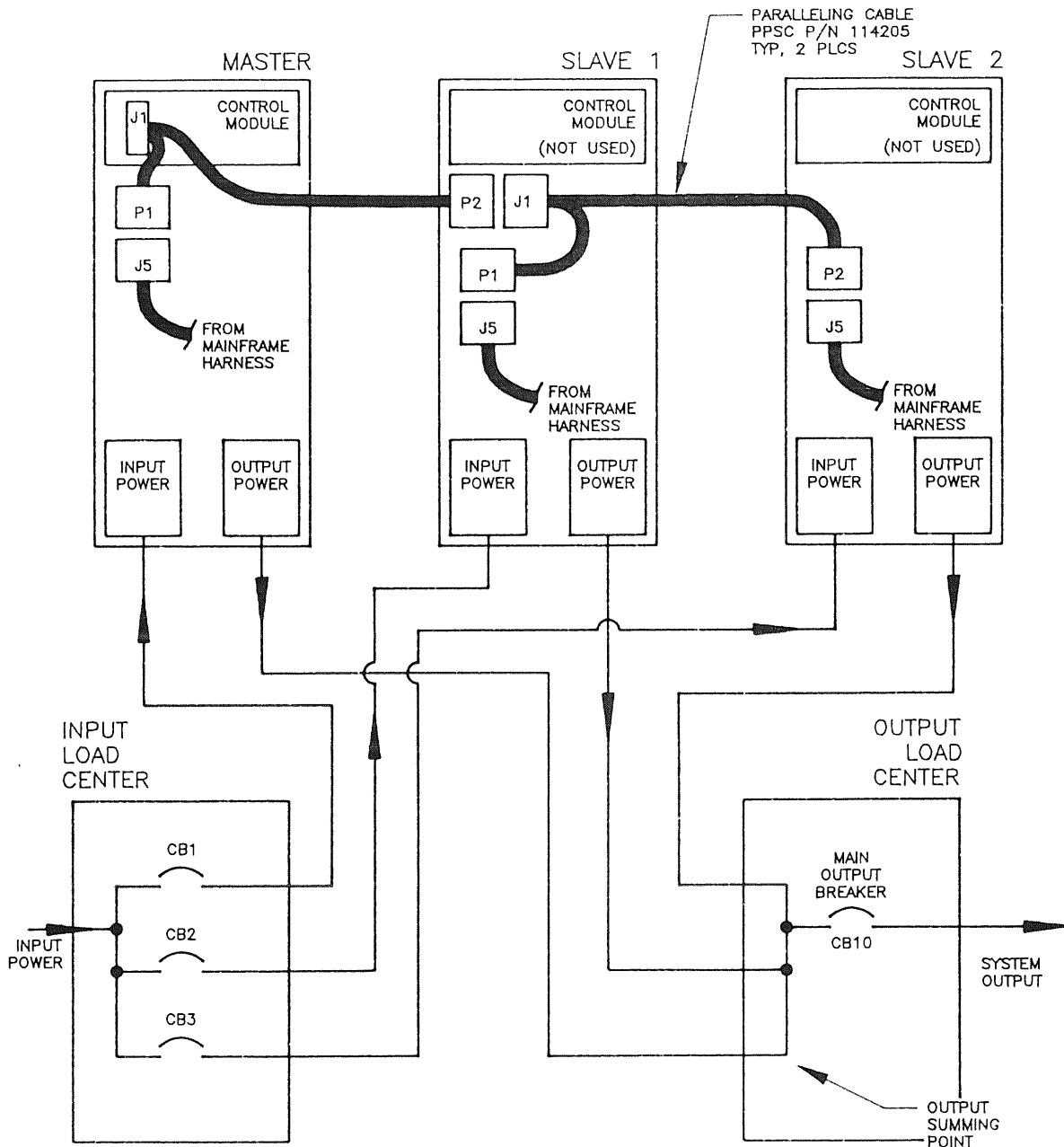

FIGURE 1

ONE-LINE BLOCK DIAGRAM
 MULTI-CABINET PLC
 (3 CABINET SYSTEM SHOWN)

2.0 INSTALLATION OF MULTI-CABINET PLC

2.1 EQUIPMENT LAYOUT AND CABLING

In addition to other site considerations the installer should consider the following:

1. Cabinets are best kept side by side to keep the signal paralleling cable(s) short.
2. Power cables from the input load center may be as long as desired. However the input load center should be in the same room as the power source in order to facilitate emergency shut-down.
3. Output cables from each PLC cabinet to the summing point within the output load center should be kept short, but most importantly, should be all the same length to prevent uneven load sharing among cabinets. Lengths must match to within 1 foot and wire gauges must be identical.

CAUTION

- * POWER SOURCE CABINETS ARE PARALLELEABLE.
- * WHEN PARALLELED, OUTPUT CIRCUIT BREAKERS OR CONTACTORS BETWEEN MAINFRAMES MUST NOT BE USED.
- * USE OF EXTERNAL CONTACTORS OR CIRCUIT BREAKERS FOR DISCONNECTING INDIVIDUAL CABINETS WILL CAUSE SEVERE DAMAGE TO SYSTEM WIRING.

CAUTION

TM-0065

DTD March 6, 1990

G-SERIES PARALLEL OPERATION

2.0 INSTALLATION OF MULTI-CABINET PLC (con't)

2.2 INSTALLATION AND START-UP

With input power safely OFF, install all cabinets, input and output load centers. Connect system signal and power wiring as shown in Figure 2. (Refer to Figure 3 for 1 ϕ Output Systems.)

REMEMBER, power cables from each cabinet to the Output Summing Point must be same size and length. Also, circuit breakers or contactors are not allowed between the cabinet output terminals and the Output Summing Point.

C A U T I O N

* **USE OF EXTERNAL CONTACTORS OR CIRCUIT BREAKERS BETWEEN INDIVIDUAL CABINETS AND THE OUTPUT SUMMING POINT WILL CAUSE SEVERE DAMAGE TO SYSTEM WIRING.**

C A U T I O N

Start-up of the MASTER cabinet is as follows:

1. Input power mains must be OFF.
2. Open the front door to each power source cabinet and turn OFF the input circuit breaker and, most important, **TURN OFF THE OUTPUT TOGGLE SWITCH OF EACH AND EVERY POWER MODULE, IN EACH AND EVERY CABINET.**
3. Close the main input circuit breaker of the input load center.
4. At the MASTER cabinet, turn Output Amplitude to zero (fully ccw).

Verify that the main output circuit breaker, if present, is open or that no loads are attached to the system output.

Close the input circuit breaker of the MASTER cabinet.

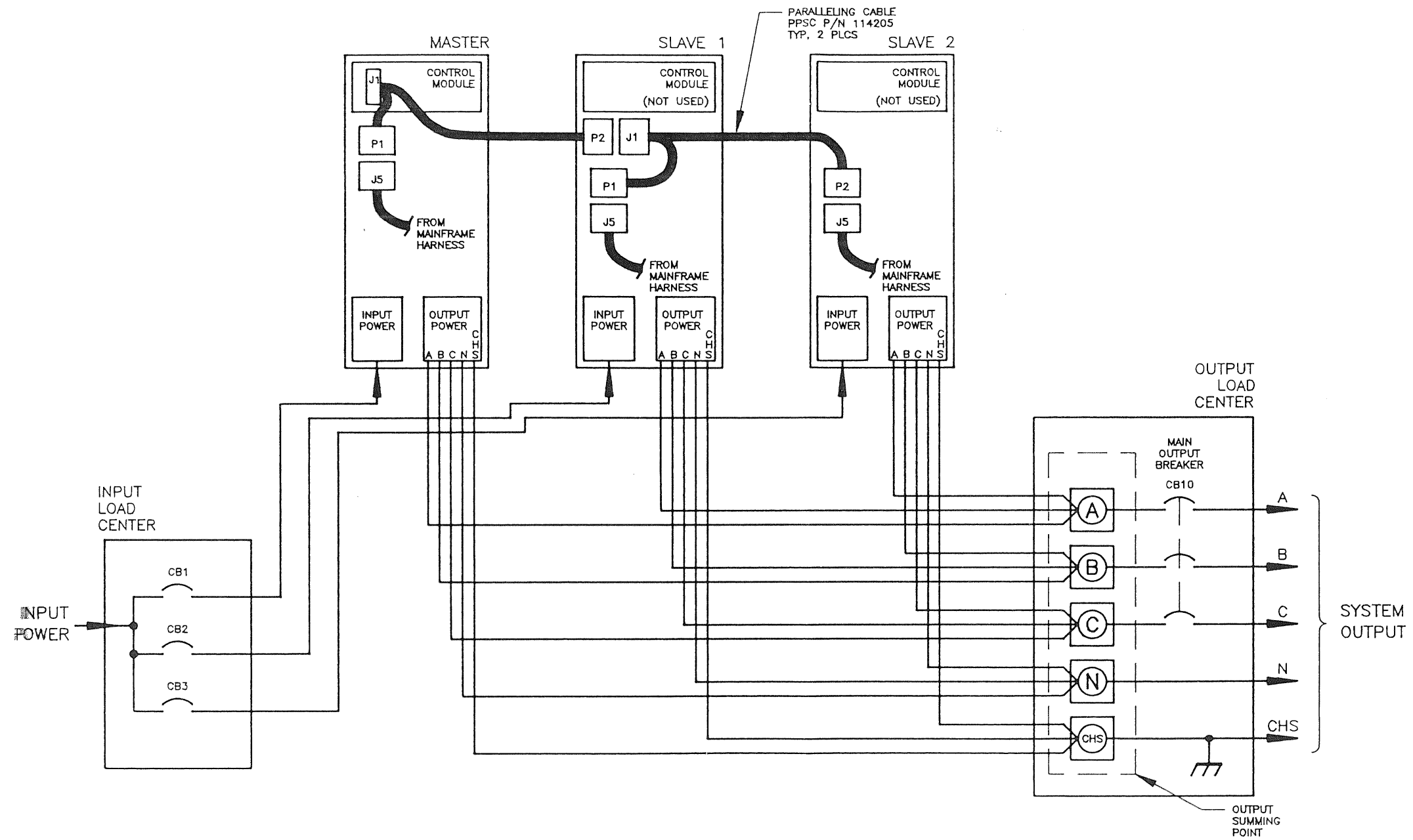

- 2. INPUT WIRING REPRESENTED IN ONE-LINE FORMAT.
- 1. CIRCUIT BREAKERS OR CONTACTORS NOT ALLOWED ON CONNECTIONS BETWEEN MAINFRAME OUTPUT AND OUTPUT SUMMING POINT

NOTES: UNLESS OTHERWISE SPECIFIED

FIGURE 2
 OUTPUT WIRING DIAGRAM
 MULTI-CABINET PLC
 3 ϕ OUTPUT
 (3 CABINET SYSTEM SHOWN)

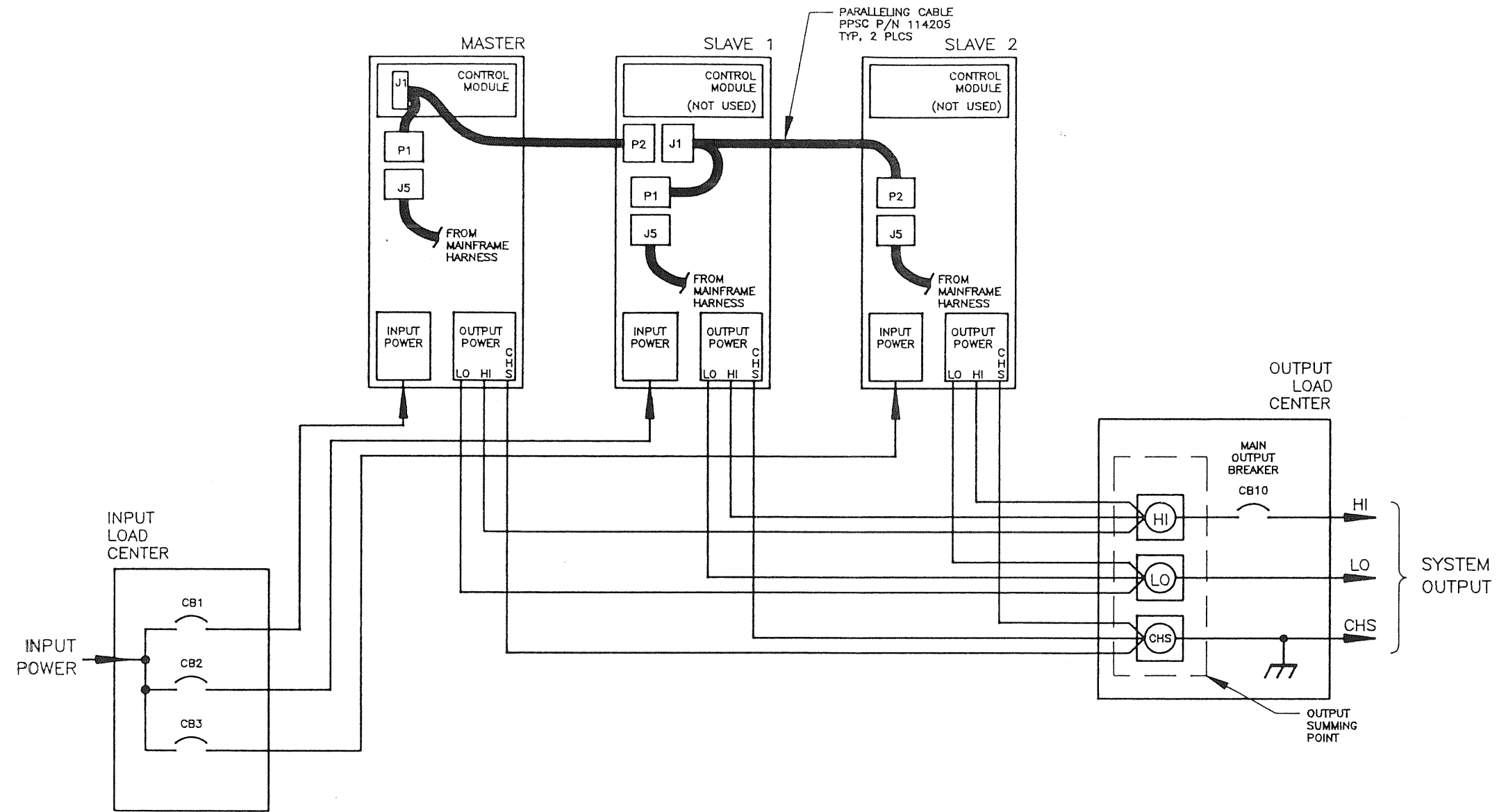

- 2. INPUT WIRING REPRESENTED IN ONE-LINE FORMAT.
- 1. CIRCUIT BREAKERS OR CONTACTORS NOT ALLOWED ON CONNECTIONS BETWEEN MAINFRAME OUTPUT AND OUTPUT SUMMING POINT

NOTES: UNLESS OTHERWISE SPECIFIED

FIGURE 3
 OUTPUT WIRING DIAGRAM
 MULTI-CABINET PLC
 1Ø OUTPUT
 (3 CABINET SYSTEM SHOWN)

2.0 INSTALLATION OF MULTI-CABINET PLC (con't)
2.2 INSTALLATION AND START-UP (con't)

5. One-by-one, turn ON all of the MODULE OUTPUT switches on the power modules of the MASTER cabinet only.

Slowly increase the Output Amplitude of the MASTER cabinet control module. If any module shows significant current, stop and investigate for possible loads, shorts or miswires on the system output.

Increase amplitude to normal output. Press the On-Off push button to energize the cabinet's output contactor.

Verify, with a voltmeter, that 120/208 volts is present on the output bus.

At this point the system is energized with only the MASTER cabinet on-line. If testing or operation with one cabinet is desired, it can be conducted at this time.

The addition of a SLAVE cabinet is described below. Of course, a SLAVE cabinet can only be added after normal operation with the MASTER is verified. Be sure that MASTER and all SLAVE signal cables are wired properly.

1. Leave MASTER cabinet and the output bus energized. Make sure there is no load on the system and that the main output circuit breaker (CB-10, Ref. Fig. 2) of the output load center is OFF.
2. Close the input circuit breaker of the SLAVE cabinet to be added. Turn on the Module OUTPUT switch of the top power module. Verify no significant module current. (Module current is abnormal since there is no system load and indicates a miswire on the output bus).

One-by-one, turn on the module OUTPUT switches of the remaining power modules, verifying no module current. Repeat until all Module Output switches are ON.

3. Repeat above procedure for each SLAVE cabinet.

Once all Slave cabinets are connected, the load may be attached to the output. When the load is attached, verify that each power module is delivering its share of the load. Modules on a particular phase should share current to within $\pm 10\%$ of each other.

3.0 OPERATION AND SERVICE OF MULTI-CABINET PLC

3.1 SYSTEM ON-OFF CONTROL

Multi-cabinet PLC systems can be turned ON and OFF in one of three ways:

METHOD 1:

By opening the main output circuit breaker of the output load center (if present).

METHOD 2:

By using the Output On-Off push button on the MASTER cabinet control module.

METHOD 3:

By opening the main input circuit breaker of the input load center.

Methods 1 and 2 are the preferred methods of ON-OFF control, since there is substantial evidence that the equipment is more reliable when left ON at all times. Method 1 is best for disconnecting large loads, while leaving the system fully operational.

Method 2 leaves the system operational but, in addition, removes the voltage from the output bus. If possible, the load should be disconnected by Method 1 first followed by Method 2. This will make a "cleaner" disconnect from the load rather than using Method 2 alone.

Method 3 should be used only for emergency shut-down and not as a routine method of shutting down the system. If the system must be de-energized for maintenance purposes, it is always preferable to first turn OFF the output by Method 1 followed by Method 2 and finally ended with Method 3.

3.2 SYSTEM MAINTENANCE

3.2.1 ROUTINE OBSERVATIONS

One of the benefits of PACIFIC multi-cabinet systems is the added reliability of redundant units with limited failure propagation. The routines described in this section are primarily designed to assist the user in shutting down a portion of the system while continuing his mission with the remainder. However, the service technician may also find a few suggestions helpful in the actual safe conduct of repairs without disruption of system power.

Routine observations should be made to ascertain normal operation. Though complete maintenance observations are outside the scope of this memo a few of the most important are repeated:

1. Make sure input line meters on each cabinet are in the green region. Excessive input line voltage can cause a unit to run "hot" and reduce reliability.
2. Check all fans. Make sure they turn at full RPM.
3. Check all modules for failure lights. A few lights do not matter - several lights may indicate that service is required.
4. Check for load current balance (module ammeters). In a good systems installation ammeters should agree within 10% with the system loaded heavily - greater imbalance is normal at light loads.
5. Check for excessive accumulation of dust in the power modules.

3.2 SYSTEM MAINTENANCE (con't)

3.2.2 POWER MODULE EXCHANGE

When it is determined that a power module requires service, it can be exchanged simply by:

1. Turning the Module OUTPUT switch OFF.
2. Disconnecting the single connector at the front of the module.
3. Physically removing the power module from the cabinet.

The replacement power module can be installed by:

1. Sliding it into place and tightening the captive fasteners on the front of the power module.
2. Verifying that the Module OUTPUT switch is OFF and then make connecting the module connector.
3. Turning the Module OUTPUT switch ON and verifying hat the power module delivers proper its share of output current.

3.2 SYSTEM MAINTENANCE (con't)

3.2.3 SLAVE CABINET SHUTDOWN

If it is determined that a SLAVE cabinet must be electrically removed from the system, this can be done without system shutdown or interruption of power to the load as follows:

1. Turn OFF the OUTPUT toggle switch at EACH and EVERY power module of the SLAVE cabinet to be isolated.
2. Turn OFF the input circuit breaker of the SLAVE cabinet to be isolated.

The unit is now disconnected from the system load.

Cabinet repairs should not be attempted in this state since the cabinet still contains hazardous voltages applied by the signal paralleling cable.

3.2.4 MASTER CABINET SERVICE

Should it become necessary to shut down or repair the MASTER cabinet, the entire system must be de-energized, following the procedures outlined in paragraph 2.2.

Once de-energized, the paralleling cables at the back of the cabinets can be re-arranged to utilize a different cabinet as MASTER. The original MASTER can be left isolated from the grid by using the procedure in paragraph 3.2.3 above.