

## Field-Induced Conductivity Changes in Germanium

H. C. MONTGOMERY AND W. L. BROWN  
*Bell Telephone Laboratories, Murray Hill, New Jersey*  
 (Received April 26, 1956)

Variations in the conductance of a germanium filament due to an electric field normal to the surface were measured for fields up to  $10^6$  volts/cm. Observation of a minimum in the conductance curve makes it possible to calculate charge in surface states as a function of surface potential. Information of this sort obtained with several gaseous ambients is compared with the Brattain-Bardeen observations on contact potential. Measurements as a function of temperature down to 170°K give information about properties of "fast" surface states. Phase shift loops observed at frequencies around a kilocycle are interpreted in terms of minority carrier lifetime. Phase shift loops at low temperatures are believed to be due to traps.

WHEN a semiconductor is made one plate of a condenser, the electric field resulting from a voltage applied to the condenser will induce a net charge on the semiconductor. If this charge is provided by changes in the numbers of mobile holes or electrons in the material, then there will be a change in conductivity accompanying a change in the voltage on the condenser. This effect, often called the field effect, was studied by Shockley and Pearson<sup>1</sup> and more recently by others.<sup>2</sup> In practice one finds that the changes of conductivity are considerably smaller than would be expected if all the induced charge appeared as changes in the mobile carrier densities. One attributes the discrepancy principally to surface states: localized states in the forbidden energy gap at the surface.<sup>3</sup> A large part of the charge induced on the condenser appears more or less quickly in these states and does not contribute to the conductivity. The sensitivity of the measured conductivity change to these surface states has made this an attractive method for studying semiconductor surfaces.

With a sufficiently large induced charge, the surface region can be changed from *n* type to *p* type or vice versa. In the course of such a change the conductivity goes through a minimum value at a point where the changes due to holes and electrons just balance one another. One of the authors has shown that when such a minimum is observed, the electrostatic potential of the surface can be calculated for any point on the curve relating conductivity to applied voltage.<sup>4</sup> One is then in a position to determine certain properties of the energy distribution of the surface states. One advantage of the method of observing field effect to be described here is that it gives the conductivity curve for a large applied signal, so that the minimum can often be observed directly. We will show the results of several types of observations which we have made on germanium in this way.

<sup>1</sup> W. Shockley, *Electrons and Holes in Semiconductors* (D. Van Nostrand Company, Inc., New York, 1950), Sec. 2.1b.

<sup>2</sup> For extensive references see R. H. Kingston, *J. Appl. Phys.* **27**, 101 (1956).

<sup>3</sup> J. Bardeen, *Phys. Rev.* **71**, 717 (1947).

<sup>4</sup> W. L. Brown, *Phys. Rev.* **100**, 590 (1955).

The specimen is a rectangular bar of single crystal germanium about  $0.5 \times 1.5 \times 10$  mm, with contacts soldered to the ends. The surface is etched with CP-4 or a basic etch. Both *n*- and *p*-type material have been used, in the resistivity range from 10 to 40 ohm-cm.

An electric field is produced by making the germanium one plate of a condenser, whose dielectric is a slab of single crystal strontium titanate about 0.5 mm thick, having a dielectric constant of 300. This material is not ferroelectric, and is a well-behaved dielectric over a wide range of frequency and temperature.<sup>5</sup> The mating surfaces of the germanium and the dielectric are optically polished, and capacity measurements indicate a residual air gap of only a few microns.

A sinusoidal voltage of tens or hundreds of volts is applied to the condenser and to the horizontal axis of an oscilloscope (Fig. 1). Changes in conductance of the germanium due to the field effect are detected by passing a constant dc current of one or two milliamperes through the specimen, and displaying the resulting voltage changes on the vertical axis of the scope. The displacement current through the condenser produces a voltage drop across the germanium specimen which is not part of the field effect. This voltage is balanced against a similar voltage from an *R-C* circuit in a differential amplifier, and does not appear on the scope. Thus the pattern on the scope is a plot of conductance against electric field. The apparatus works over a frequency range from a fraction of a cycle to several

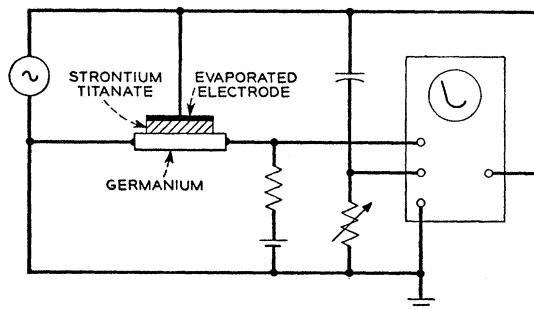

FIG. 1. Schematic of apparatus for measuring field effect.

<sup>5</sup> Arthur Linz, Jr., *Phys. Rev.* **91**, 753 (1953).

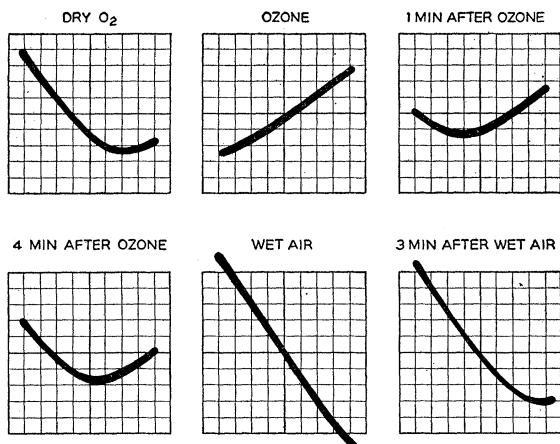

FIG. 2. Field-effect patterns in various gaseous ambients for *p*-type germanium at room temperature.

kilocycles per second, being limited by stability of the preamplifiers at low frequencies and the degree to which the displacement current can be balanced out at high frequencies.

#### FIELD EFFECT PATTERNS

Figure 2 shows some typical field effect patterns, photographed from the oscilloscope screen. The horizontal axis represents charge per unit area supplied to the specimen

$$\Sigma_T = VC/S,$$

where  $V$  is the voltage applied to the condenser of which the specimen forms one plate,  $C$  is the capacity, and  $S$  the area of the condenser. The vertical axis represents change in conductance of the specimen per unit square of surface

$$\Delta G_1 = \Delta v L / IR^2 W,$$

where  $I$  is the dc current through the specimen of resistance  $R$ , length  $L$ , and width  $W$ , and  $\Delta v$  is the voltage change across the specimen due to field effect. ( $R$ ,  $L$ , and  $W$  refer to that portion of the specimen which is within the condenser.)

The patterns of Fig. 2 are for a specimen of *p*-type germanium with a resistivity of 40 ohm-cm at room temperature,  $R=5700$  ohms. The surface was polished and etched with a sodium hydroxide-Superoxol etch. An applied voltage of  $\pm 14$  volts peak was used at 100 cycles per second. The condenser capacity was  $38 \times 10^{-12}$  farad, length 0.97 cm, width 0.15 cm. Consider the first pattern, marked "dry  $O_2$ ." At the left end of the curve an (algebraic) increase in charge results in a decrease in conductance, indicating that conduction is predominantly by electrons and that the behavior of the surface region is *n* type. At the right end of the curve, the opposite is true and the surface is *p* type. At the origin, with no applied voltage, the surface is *n* type, and since the specimen is *p* type we

conclude that the chemical conditions at the surface are such as to produce an inversion layer. This is rather common with *p*-type material of high resistivity in air or oxygen. This curve clearly shows the minimum, at which for a positive increment of charge the contributions to conductivity from increasing hole concentration and decreasing electron concentration just cancel one another.

The slope  $d(\Delta G_1)/d\Sigma_T$  has the dimensions of mobility ( $\text{cm}^2/\text{volt-second}$ ), and will be defined as the effective mobility. At the extremes of the conductance curve, where we are dealing with only one type of carrier, it gives the average mobility of the carriers induced on the semiconductor, including those in surface states. Generally the effective mobility is less than bulk mobility because (a) a large fraction of the carriers go into surface states where they have a very low mobility, and (b) there may be a reduction in mobility of the remaining carriers due to constraint at the surface.<sup>6</sup> Near the conductance minimum the effective mobility is further reduced by the competing effect of holes and electrons.

#### EFFECTS OF OZONE AND WATER VAPOR AMBIENTS

The specimen was subjected to an ambient atmosphere of oxygen containing ozone produced by ultraviolet irradiation. Within a second or two the minimum in the field effect pattern shifted well to the left, leaving a strongly *p*-type surface, as shown in the second pattern of Fig. 2. No further change was observed in a minute or so. Despite the close fit between the germanium surface and the dielectric material, the gas penetrated almost instantly. When ozone was removed, the pattern returned gradually to its original form, as shown in the next two pictures, taken one and four minutes after the ozone generator was turned off. Return to the initial form was substantially complete in 15 minutes.

The next pattern was produced by moist air. The minimum shifted far to the right, leaving a strongly *n*-type surface. As in the case of ozone, the change was complete in a second or two. Again, the pattern returned slowly to its initial condition when the specimen was exposed to dry oxygen, as shown in the last pattern taken 3 minutes after removal from wet air. The return was substantially complete in 15 minutes.

Since the preamplifier did not pass direct current, the vertical position of the various patterns is arbitrary. The appearance of these patterns strongly suggests that they are portions of a single larger pattern, and that the effect of the gaseous ambients is chiefly to shift the operating point along the master curve. With this in mind, the six curves of Fig. 2 have been superposed after suitable shifts horizontally and vertically, making the composite curve shown in Fig. 3. It will be noted that the individual curves superpose very satis-

<sup>6</sup> J. R. Schrieffer, Phys. Rev. **97**, 641 (1955).

factorily. Small arrows show the position of the origin with the various gaseous ambients. The horizontal and vertical scales are marked off in units of  $\Sigma_T$  and  $\Delta G_1$ , as defined in the preceding section. The total vertical excursion represents a conductance change of about 1%. The zero of the horizontal scale is arbitrarily taken appropriate to the oxygen ambient.

The total charge density  $\Sigma_T$  consists of a portion  $\Sigma_{sc}$  in the space charge layer, which contributes to the conductivity, and a portion  $\Sigma_{ss}$  immobilized in surface states. The experimental curve relates  $\Delta G_1$  to  $\Sigma_T$ . Included in Fig. 3 is a theoretical curve relating  $\Delta G_1$  to  $\Sigma_{sc}$  and a quantity  $\Delta$  which is related to the surface potential  $Y$  as shown in the inset in Fig. 4. Note that  $\Delta$  is expressed in electron volts, while  $Y$  is in units of  $kT/e$ ; aside from this difference in units, the two quantities differ by a constant in a given specimen at a fixed temperature. The method of calculating the  $\Sigma_{sc}$  curve and transferring the values of  $\Delta$  (or  $Y$ ) to the experimental curve are as described by one of the authors.<sup>4</sup>

From these curves it is seen that in the absence of any applied voltage, wet air increases the surface potential by about 0.04 volt, while ozone decreases it by about 0.10 volt. Brattain and Bardeen<sup>7</sup> reported changes in contact potential with similar ambients which were in the same direction as our changes in surface potential, but the over-all change was larger by a factor of three or so. Surface potential is the potential just inside of the surface layer, and differs from contact potential by any potential changes due to charges or dipoles in an external surface layer. Comparison of the two experiments indicates that the changes in such potentials due to ambient are by no means negligible.

From the horizontal displacements of the theoretical and experimental curves in Fig. 3, one can obtain a relation between  $\Sigma_{ss}$  and  $\Delta$ , as shown in Fig. 4. This may be compared with Fig. 2 of reference 4 which shows this relation for a different specimen, and over a

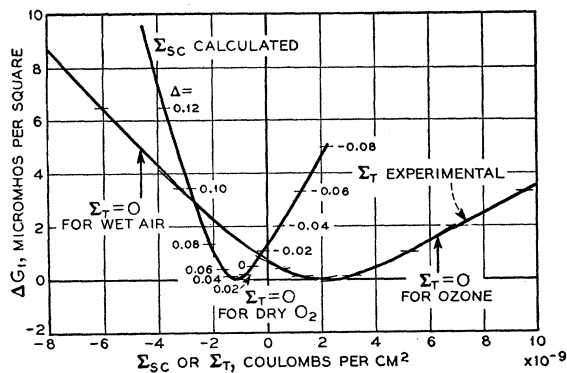

FIG. 3. Composite field-effect pattern compared with calculated changes of charge in the space-charge layer.

<sup>7</sup> W. H. Brattain and John Bardeen, Bell System Tech. J. 32, 1 (1953).

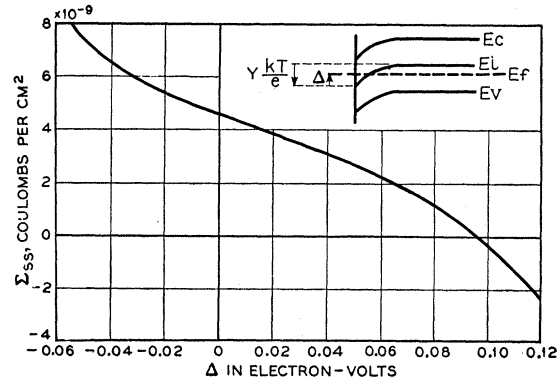

FIG. 4. Changes in charge in fast surface states plotted against  $\Delta$ . Inset shows relation between  $\Delta$  and surface potential,  $Y$ .

more restricted range. The two curves are similar in shape, but differ somewhat in detail, due presumably to differences in acceptor concentration and surface treatment of the two specimens. A curve of this sort can provide information concerning the energy distribution of the surface states if all the changes in  $\Sigma_{ss}$  during a cycle occur in states whose filling is completely described by  $\Delta$ . Physically, this requires that these states be located at a position in the surface layer where the potential is not substantially different from that of the semiconductor interface. A calculation of the surface state distribution is not affected by states more remote from the interface provided that they are too slow to follow the changes in external electric field. However, one also gets no information as to the energy of such states. Mathematically, a unique determination of the fast state distribution requires a knowledge of  $\Sigma_{ss}$  over an infinite range of  $\Delta$ , but useful information can be obtained from a more restricted range.

The curve of Fig. 4 is nearly symmetrical about  $\Delta=0.025$  ev. It can be fitted within experimental error by a pair of surface state groups of equal concentration at energy levels  $\Delta=0.025\pm 0.05$  ev and another pair 25 times as concentrated at  $\Delta=0.025\pm 0.175$  ev. This is the simplest distribution which will suffice. Many more complicated distributions will do as well, ranging all the way to a continuous distribution whose central part would be quite definite, but whose remote portions would be only loosely determined. It seems clear that the experimental curve cannot be fitted by any array of states lying wholly outside of the range  $\pm 0.2$  ev ( $\approx 7kT$ ) from the point of symmetry. Any such array gives very nearly a hyperbolic sine relation, which is too flat at the center to agree with the experimental curve.

FREQUENCY-DEPENDENT EFFECTS

The field-effect patterns change very little over the frequency range from a few cycles per second up to about a kilocycle per second. At frequencies much less than a cycle per second the field effect is often reduced

by an order of magnitude or more. This is believed to be due to surface states with relatively long time constants which immobilize a large fraction of the carriers when the cycle is slow, but which do not have time to act at higher frequencies. Properties of these slow surface states have been investigated by various workers.<sup>8,9</sup>

The constancy of the field effect from a few cycles/sec to a kilocycle/sec indicates that in our specimens there were practically no surface states having time constants in the corresponding range, say 50 milliseconds to 200 microseconds.

At higher frequencies, loops begin to appear in the field effect patterns of both *n*- and *p*-type material. These loops always occur on the side of the pattern corresponding to minority-carrier conduction. The frequency at which they are prominent is higher for short-lifetime (sandblasted) than for long-lifetime (etched) surfaces, and this frequency (with a factor of  $2\pi$ ) is of the order of the reciprocal of the lifetime of minority carriers in the specimen. It seems possible to explain this behavior along the following lines. When conduction in the space charge layer is chiefly by minority carriers, changes in charge must occur through the generation-

recombination process characterized by the lifetime  $\tau$ , since minority carriers cannot be supplied through the ohmic contacts at the ends of the specimen. At frequencies of the order of  $1/\tau$ , there is a delay in supplying minority carriers and again in recombining them on each cycle. This delay gives rise to a loop in the field-effect pattern. At still higher frequencies, the charge requirements would be met almost entirely by majority carriers, and the field-effect pattern should approach a straight line with slope having a sign appropriate to majority carriers. This region has not been seen experimentally because of phase shifts in the measuring circuits and the difficulty in balancing out the displacement current in the condenser.

To a large alternating voltage we have sometimes suddenly added a dc biasing voltage on the condenser. A few milliseconds after applying the bias, the ac field effect appears to be shifted to a new operating point along a master curve. However, with longer times the pattern always tends to drift as though the effect of the bias were slowly being lost, but often stops short of return to the initial condition. The drift is characterized by times which range from a fraction of a second to several minutes, depending upon the sample and its surface condition. This effect is another way of observing the presence of slow surface states.

A second type of drift has been observed in the absence of any dc voltage. If one increases the ac voltage applied to the condenser, starting with some small value, the pattern at first simply grows by extension at both ends without change in the portion traversed at lower voltages. However, when the voltage becomes quite large the pattern does not simply grow as the voltage is increased, but in addition shifts along the applied voltage axis much as though one were applying a dc voltage. The extent of this effect and even the direction of the drift vary from sample to sample, and in some cases the shape of the curve changes appreciably. We believe that the phenomenon is again the result of slow surface states, charging in this case, not because they are given a long time to do so, but rather because their filling times are shortened by the very high applied fields.

#### FIELD EFFECT AT REDUCED TEMPERATURES

Measurements of field effect were made at reduced temperatures on *n*- and *p*-type germanium. The specimens were housed in a glass tube in a vacuum  $10^{-3}$  mm Hg to reduce effects due to water vapor. Typical patterns showing field effect at several temperatures are shown in Fig. 5. This is for the same *p*-type sample used for the data of Fig. 2.

As the temperature was reduced, the position of the minimum moved to the left on the scale of  $\Sigma_T$ . It can be shown that the minimum occurs when the middle of the band is approximately as far below the Fermi level at the surface as it is above the Fermi level in the

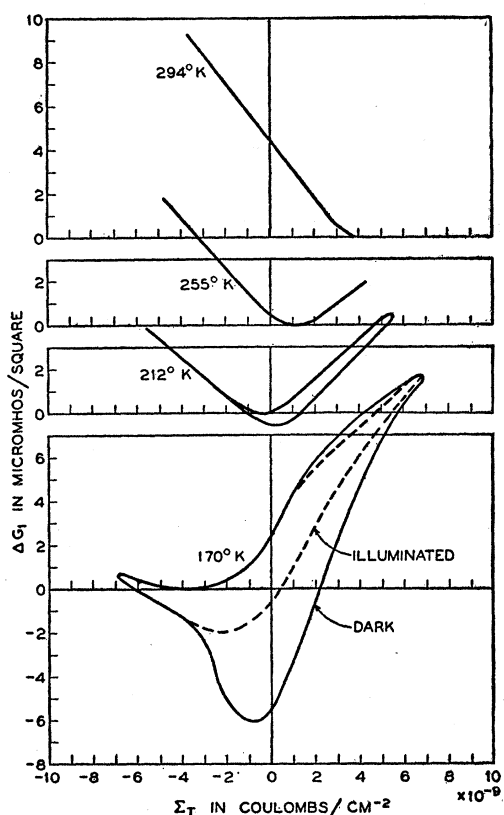

FIG. 5. Field-effect patterns for *p*-type germanium at various temperatures.

<sup>8</sup> Statz, de Mars, Davis, and Adams, Phys. Rev. **101**, 1272 (1956).

<sup>9</sup> R. H. Kingston and A. L. McWhorter, Phys. Rev. **98**, 1191 (A) (1955).

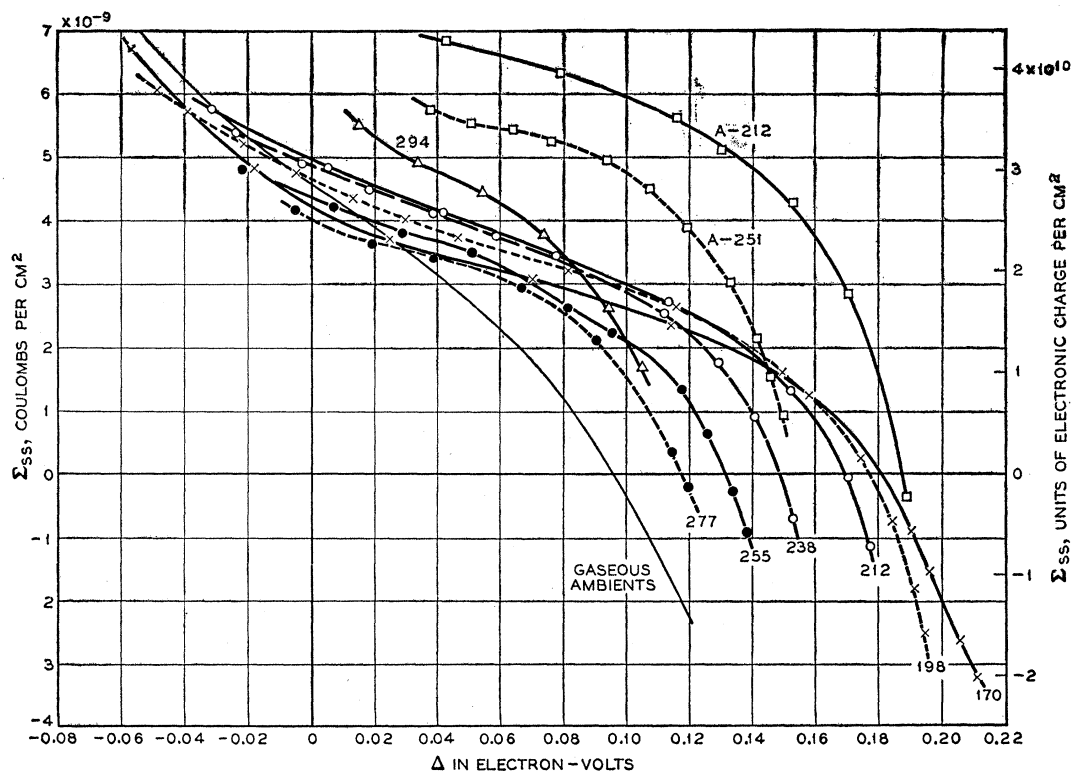

FIG. 6. Changes in charge in fast surface states as a function of temperature. Figures near curves give temperature in degrees Kelvin. Curves marked *A* were taken on the ascending branch of the temperature cycle. "Gaseous ambients" curve is a copy of Fig. 4.

interior.<sup>10</sup> As the temperature decreases, the Fermi level becomes nearer the valence band in the interior, hence nearer the conduction band at the surface. The observed behavior of the minimum as a function of temperature is thus qualitatively that to be expected both from the change in filling of the surface states and from the change in the space charge region. While the minimum always moved in a consistent direction with changes in temperature, the relation between the position of the minimum and temperature was only roughly the same on the downward and upward portions of the temperature cycle and on successive cycles.

From the slope of the field effect curves one deduces an effective mobility of 1050 cm<sup>2</sup>/volt-second at room temperature and 700 at 212°K, on the *n*-type branch of the curves. Bulk mobility for electrons is 3800 and 7000, respectively,<sup>11</sup> so the ratio of effective to bulk mobilities is 0.28 at room temperature and 0.10 at the lower temperature.

Field-effect patterns were obtained for an *n*-type specimen (10 ohm-cm at room temperature) at temperatures down to 186°K. These were not of great quantitative significance because none of the curves

included the minimum, although it appeared to be just beyond the end of the curve in many cases. There was no inversion layer; the surface was always *n* type. The effective mobility was smaller at the lower temperatures, by about the same factor as in the *p*-type specimen.

A prominent feature of the patterns in both *n*- and *p*-type material is a loop which appears at the lower temperatures. This loop is chiefly on the side of the pattern corresponding to hole conduction for either type of sample. Under illumination, the loop collapses toward its upper branch. It seems likely that these loops are due to traps of the sort described by Haynes and Hornbeck,<sup>12</sup> which are important only at low temperatures and which can be saturated with carriers generated by illumination.

From the field effect patterns at various temperatures, curves relating  $\Sigma_{ss}$  to  $\Delta$  were derived, as described in connection with Fig. 4. These are shown in Fig. 6. In deducing these curves we have neglected any reduction in mobility of the carriers near the surface. In the field effect curves at the lower temperatures where loops appear we have analyzed the upper branch of the loop.

In Fig. 6, the six curves which lie close together at  $\Delta=0.05$  were taken on a run during which the tem-

<sup>10</sup> C. G. B. Garrett and W. H. Brattain, Phys. Rev. **99**, 376 (1955).

<sup>11</sup> F. J. Morin and J. P. Maita, Phys. Rev. **94**, 1525 (1954).

<sup>12</sup> J. R. Haynes and J. A. Hornbeck, Phys. Rev. **90**, 152 (1953).

perature was decreasing. The consistency of their variation with temperature makes it credible that we are measuring a particular distribution of surface states as a function of temperature and not a change in the surface states themselves resulting, for example, from a change in surface chemistry. For values of  $\Delta$  around zero (the Fermi level near the middle of the band) there is remarkably little change in the slopes of the curves in this family. Since the contributions from remote states should be strongly temperature dependent, this implies a significant concentration of surface states more or less uniformly distributed near  $\Delta=0.05$  with a density of about  $10^{11}$  states/cm<sup>2</sup>-volt.

For large positive values of  $\Delta$ , there are sharp changes in slope, representing additional surface states coming into play. The lower the temperature, the larger is the value of  $\Delta$  at which the change in slope occurs. This is at least roughly what one would expect from a high density of states located beyond the extreme limit of observation. The lower the temperature, the closer one must get to these states before their influence is felt. The temperature variation of the field effect thus gives added support to the notion that there is an appreciable density of surface states within the range of our present observation and an even larger density somewhere beyond it.

The self-consistency of the curves taken with decreasing temperature is thought to be due to removal of residual water vapor by condensation on the walls of the tube, which in this situation are colder than the sample. The three stray curves of Fig. 6 were taken on the ascending part of the temperature cycle or with temperature stationary. They are very similar to the curves on the downward part of the cycle, except shifted along the  $\Sigma_{ss}$  axis. The direction of this shift is what one would expect from an increase in water vapor on the surface. This sort of consideration may account for the lack of reproducibility between different cycles that was mentioned earlier.

#### SUMMARY

From the field-effect measurements that have been described, we can make several fairly general statements about the fast surface states that exist on the type of etched germanium surface we have examined. From the lack of frequency dependence in the low audio range, we know that the fast surface states have time constants certainly shorter than 200 microseconds. From the changes in ambient which leave the shapes of the field effect curves essentially unchanged, simply shifting the operating point of the measurements, we can say that the fast surface states are at least approximately unchanged by the ambient and hence appear to be more intimately related with the germanium than the outside of the oxide layer. The dependence of the charge in the surface states on  $\Delta$ , at a single temperature and as a function of temperature, indicates that near the middle of the band gap there is an almost uniform distribution of states with a density approximately  $10^{11}$  states/ev cm<sup>2</sup>. The density increases as one departs from the middle of the band, but the measurements have not been extended sufficiently far, even in the direction of the conduction band, to determine whether this increase is due to single energy levels or to a distribution of levels with high density near the band edges.

Slow surface states with time constants longer than about 0.1 second play a dominant role in the experiments with changes in ambient. There are large changes in the charge of these slow surface states as one goes through a Bardeen-Brattain gas cycle. The resulting changes in surface potential have been determined to be of the same sign as, but smaller by as much as a factor of three, than the contact potential changes reported by those workers.

While we have not investigated them in detail, the nonequilibrium effects observed by going to low temperature or to high frequency probably can be associated with the kinetics of electron-hole transitions to the fast surface states.