

Liebert Deluxe System/3™

Technical Data Manual - Floor Mounted, 60 Hz, 6 - 30 Tons, Air, Water, Glycol and GLYCOOL Cooled



TABLE OF CONTENTS

DEDICATED, PRECISE ENVIRONMENTAL CONTROL—ESSENTIAL FOR SENSITIVE ELECTRONICS	1
LOCAL MONITORING SYSTEMS	4
STANDARD FEATURES—ALL SYSTEMS	6
STANDARD FEATURES—INDIVIDUAL SYSTEMS	8
OPTIONAL EQUIPMENT—ALL SYSTEMS	12
COMPREHENSIVE MONITORING SYSTEMS—OPTIONAL	14
COMPREHENSIVE MONITORING SOLUTIONS—OPTIONAL	15
AIR COOLED DATA	16
WATER COOLED DATA	18
GLYCOL COOLED DATA	20
GLYCOOL DATA	22
DIMENSIONAL DATA	24
ELECTRICAL SPECIFICATIONS	32
ELECTRICAL DATA—OUTDOOR AIR COOLED CONDENSERS	41
GUIDE SPECIFICATIONS	44
1.0 GENERAL	44
2.0 PRODUCT	44
3.0 EXECUTION	52
INSTALLATION AND APPLICATION GUIDELINES	53

FIGURES

Figure 1	Microprocessor control systems	5
Figure 2	Optional views with Advanced Graphics.	5

TABLES

Table 1	Comparison between comfort and precision systems	2
Table 2	Semi-hermetic compressor EER.	7
Table 3	Dimensional data—upflow models.	24
Table 4	Dimensional data—upflow models.	26
Table 5	Upflow blower / motor requirements*	26
Table 6	Dimensional data—downflow models	28
Table 7	Drycooler/condenser data	30
Table 8	Air, water, glycol cooled DH models; 3 phase, 60 cycle.	32
Table 9	Water cooled DH models with hot gas reheat	33
Table 10	Glycol cooled DH models with hot gas reheat	34
Table 11	Air, water, glycol cooled VH models; 3 phase, 60 cycle.	36
Table 12	GLYCOOL, dual cool VE models; 3 phase, 60 cycle	38
Table 13	GLYCOOL or dual cooling DE models.	40
Table 14	Outdoor air cooled condenser amperage	41
Table 15	Lee-Temp receiver heater pads	41
Table 16	Outdoor glycol pump and drycooler electrical requirements (glycol units).	42
Table 17	Glycol pump and drycooler electrical requirements (GLYCOOL units)	42
Table 18	Electrical requirements per compressor	43
Table 19	Indoor evaporator fan motor electrical requirements.	43
Table 20	Recommended free area (ft ²) for grilles or perforated panels.	54

DEDICATED, PRECISE ENVIRONMENTAL CONTROL—ESSENTIAL FOR SENSITIVE ELECTRONICS

For sensitive electronics, environmental control is more than simple cooling. “Comfort” air conditioning systems are designed for the comfort of people and simply cannot provide the kind of environment required by high performance computer or communication equipment.

Temperature Control

The high density heat load in a computer room or other similar application is beyond the capacity of ordinary air conditioning systems.

Sensitive electronics are best maintained in a stable environment of 72°F ±2°F (22.2°C ±1°C). Because computers and communications equipment generate large quantities of heat in small areas, six to 10 times the heat density of normal office space, the air conditioning system must have more than just enough cooling capacity. It must have the precision to react quickly to a drastic change in heat load and prevent wide temperature fluctuations—something a large building system cannot do.

Humidity Control

The electronic equipment must be protected from both internal condensation and static electricity discharges.

Maintaining the correct humidity level in the room is just as important as maintaining proper temperature. When humidity is too high, condensation may form inside electronic equipment and damage it. If humidity is too low, static electricity could disrupt operation or even shut down the electronic system. An ordinary building system cannot normally control the environment within these boundaries.

Air Volume

Computers and other sensitive electronics require greater air volumes than ordinary air conditioning can provide. Typical comfort systems are designed to provide between 300 and 400 CFM (cubic feet per minute), (500–700 CMH) per ton of cooling. Computer systems require between 500 and 600 CFM (850–1020 CMH) per ton. The high density heat load in a relatively small space requires more changes of air than a less dense “comfort” application.

While a normal office space requires only two air changes per hour, a room filled with electronic equipment requires up to 30 changes per hour. Without proper air volume, hot spots and temperature fluctuations could develop within the room. Also, greater air volumes provide the higher sensible heat ratios required by electronic computer equipment.

Air Filtration

A clean environment of properly filtered air is essential. Build-up of dust and fibers attracted by operating electronics can cause faults and impair the operation of electromechanical devices, such as switches and disk drives.

In short, today’s electronics need the same precision environmental control that mainframe computers need. The difference is that instead of one large computer room there are several small, often crowded rooms, widely dispersed throughout a building, plant or campus. Conditions and requirements can vary widely.

Year-Round Operation

Comfort conditioning systems cannot be relied upon 24 hours per day 365 days per year. They are typically designed to operate 10 hours per day, from spring to autumn. Many “comfort” systems have no provision for winter operation. A precision environmental control system is designed for operation at temperatures down to -30°F (-34.4°C).

Agency Listed

Standard 60 Hz units are UL listed and CSA (NRTL-C) certified. NRTL-C meets both U.S.

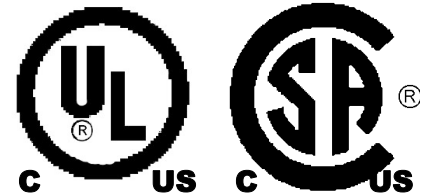

and Canadian government safety requirements, providing fast, hassle-free inspection and building code approvals. The units are also MEA listed for New York City applications.

Environmental Control—System Design Precision

The environmental control system must be able to sense and react to temperature and humidity fluctuations far too small for building HVAC systems to control.

The Deluxe System/3™ is capable of control to within ±1°F (°C) and ±1% RH. With Liebert microprocessor technology, it is possible to maintain predictive control over the environment. By analyzing the rate of change in temperature or the moisture content in the environment, the control system anticipates what is going to happen in the room, not simply respond to what has happened.

Reliability

Because electronic system availability is required 24 hours a day, 365 days a year, the environmental control system must meet the same demands.

The Deluxe System/3 is designed with the highest quality components selected for their proven reliability. Microprocessor technology adds automatic sequencing of components to even wear and extend service life. Automatic cleaning cycles can be programmed to match local water conditions. An alarm system and self-diagnostics provide rapid troubleshooting and can prevent a problem before it affects the electronic equipment room environment.

Energy Efficiency

Constant demand for precise environmental control makes energy efficiency all the more important. A well-designed environmental control system makes the most of the energy it uses.

The Deluxe System/3 is designed for maximum energy efficiency. Beginning with semi-hermetic compressors, the most reliable and energy efficient compressor available, Liebert adds an A-Frame coil that can provide 60% of total capacity with only one of the two compressors operating. Highly efficient fan motors pull air through the coil, providing not only better coil coverage, but reducing fan motor horsepower requirements.

A microprocessor control system ties all the key operational components together and responds to changes in the room environment in the most “intelligent” and energy conscious way.

Table 1 Comparison between comfort and precision systems

Desirable Feature	Building Systems	Deluxe System/3
Precision	Typically $\pm 5^{\circ}\text{F}$ (3°C)	$\pm 1^{\circ}\text{F}$ ($^{\circ}\text{C}$)/1% RH
Humidity Control	Usually None	Humidification and Dehumidification
Monitoring	None	Local and Remote
Year-Round Reliability	Not Designed for Winter Operation	Yes
Air Filtration	Negligible	20–95% based on ASHRAE 52.1
Factory Tested	No	Yes
In-the-Room Design	No. Centrally Located	Yes

Liebert Technology & Energy Efficiency

GLYCOOL

A conventional glycol system plus a second cooling coil to take advantage of colder outdoor temperatures to reduce or eliminate compressor operation. Down-flow units shown. Also available in upflow configuration.

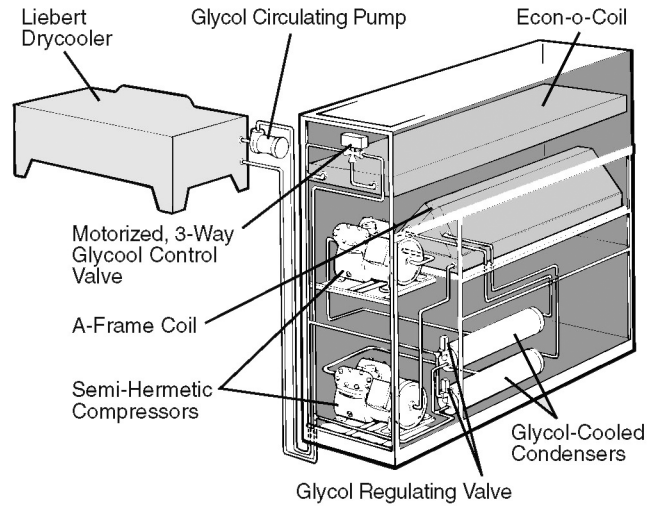

Liebert continues its world leadership in precision environmental systems by providing maximum energy efficiency without compromising the accuracy and reliability demanded by sensitive electronics. Liebert takes a no compromise approach to environmental control system design.

All enhancements to energy efficiency are designed to reduce operating time of key components and increase the Mean Time Between Failure. This is accomplished by taking advantage of alternate sources of cooling without being dependent on their availability, or by reducing compressor work load when heat load in the conditioned space is lower.

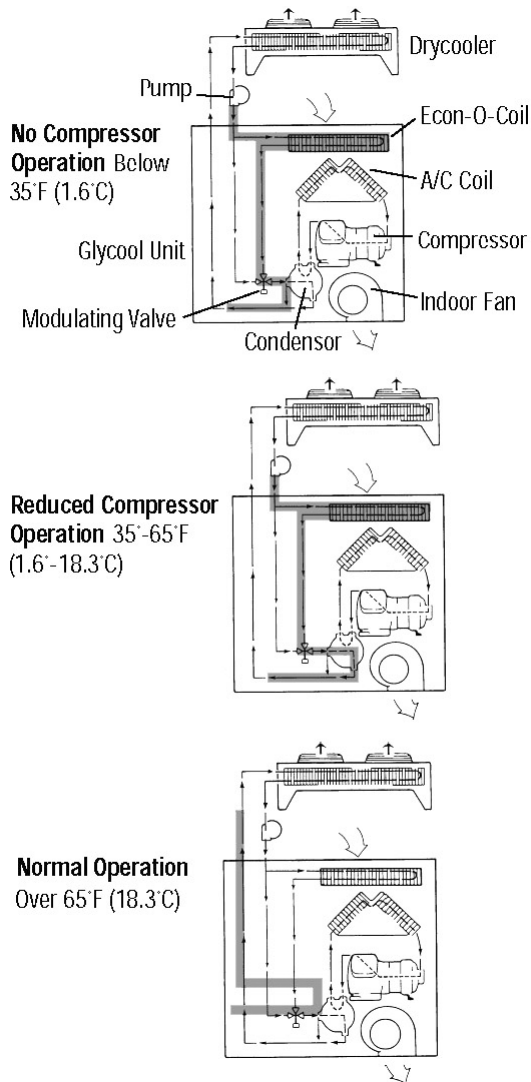

Four-Step Capacity Control Valves

Four-step capacity control valves on each compressor (air, water, glycol or GLYCOOL systems) and a specially designed microprocessor reduce compressor capacity and increase efficiency during low heat-load periods in the conditioned space.*

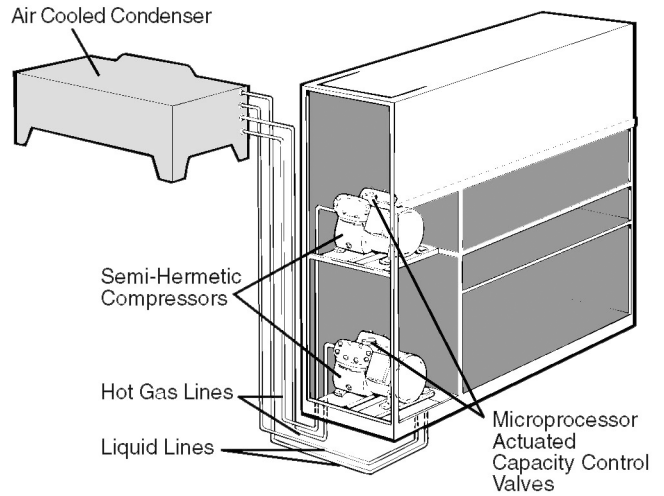

*Downflow unit shown. Also available in upflow configuration.

The Energy Efficient Dollar

Percent Room Load/Energy Consumption

95% of Maximum Room Heat Load

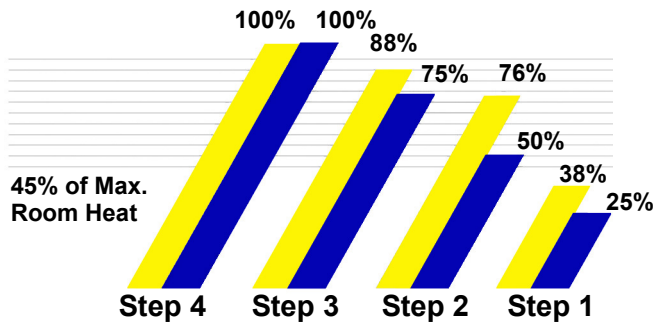

■ % of rated capacity achieved at each step
 ■ % of maximum compressor energy consumption required

Data based on DH 199 AU and outdoor ambient at 95°F (35°C)

Dual Cooling Source

A conventional air or water cooled system plus a second cooling coil to utilize a central building chiller and minimize compressor operation.*

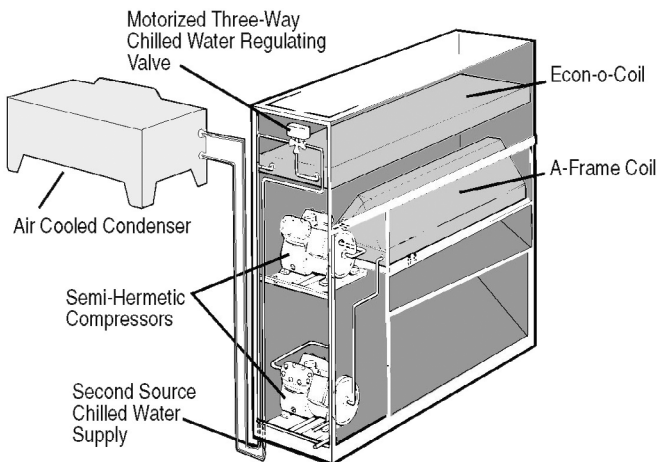

*Air cooled, downflow unit shown. Also available in upflow configuration.

LOCAL MONITORING SYSTEMS

Two levels of microprocessor control systems are available providing precise control and monitoring of the critical space.

The **Advanced Microprocessor** is standard, and the **Advanced Microprocessor with Graphics** is optional. The main control functions are similar for both controls.

Control

The user must enter a three-digit password before making changes.

- Temperature Setpoint 65-85°F (18-29°C)*
- Temperature Sensitivity +1-10°F (0.6-5.6°C)
- Humidity Setpoint 20-80% RH*
- Humidity Sensitivity 1-30% RH
- High Temperature Alarm 35-90°F (2-32°C)
- Low Temperature Alarm 35-90°F (2-32°C)
- High Humidity Alarm 15-85% RH
- Low Humidity Alarm 15-85% RH

* The microprocessor may be set within these ranges, however, the unit may not be able to control to extreme combinations of temperature and humidity.

Control Type

Factory set-up for Intelligent Control which uses “fuzzy logic” and “expert systems” methods. Proportional and Tunable PID are user selectable options.

Internal System Control

- **Compressor short cycle control:** Prevents compressor short-cycling and needless compressor wear.
- **System auto restart:** The auto restart feature will automatically restart the system after a power failure. Time delay is programmable.
- **Sequential Load Activation.** On initial start-up or restart after power failure, each operational load is sequenced to minimize total inrush current.
- **Hot Water / Econ-O-Coil Flush Cycles:** Hot water reheat coils and Econ-O-Coils are periodically flushed to prevent a build-up of contaminants.
- **Temperature/Humidity Sensor Calibration:** The sensors may be calibrated from the front monitor panel to insure that all units in the room are similarly calibrated, assuring greater precision.

Monitoring

- **Normal display:** Includes present room temperature and humidity, active functions (cooling, heating, dehumidifying), and any alarms.
- **Operating status:** Displays each control operation in percent.
- **Read analog inputs function:** Displays the present values of up to four analog inputs.

Diagnostics

- **Input diagnostics:** Reviews inputs to the control system.
- **Control board diagnostics:** Initiates a self-test of the control system.
- **Output diagnostics:** Tests major components by turning them on and off from the control panel. Includes: main fan, compressor, liquid line solenoid valve, hot gas bypass valve, chilled water or chilled GLYCOOL valve, R-5 relay, reheat, hot water reheat valve, humidifier, humidifier make-up valve, and common alarm.

Logging

- **Alarm history log:** The Advanced Microprocessor displays the 10 most recent alarms. The Advanced Microprocessor with Graphics displays the most recent 60 alarms. Both provide a time and date stamp for each event
- **Run time log:** Displays run time and hours for major components (also allows reset of run hours) including compressors, GLYCOOL, fan, humidifier, and reheat.

Alarms

- Humidifier problem
- High head pressure
- Change filter
- Loss of air flow
- High temperature
- Low temperature
- High humidity
- Low humidity
- Compressor overload (opt)
- Main fan overload (opt)
- Low suction pressure
- Short cycle
- Loss of power
- Custom alarm (choose up to 4)
 - Water under floor
 - Smoke detected
 - Standby GC pump on
 - Loss of water flow
 - Standby unit on
 - User customized text

Figure 1 Microprocessor control systems



Advanced Microprocessor Control System. Backlit 4 x 20 Liquid Crystal Display.

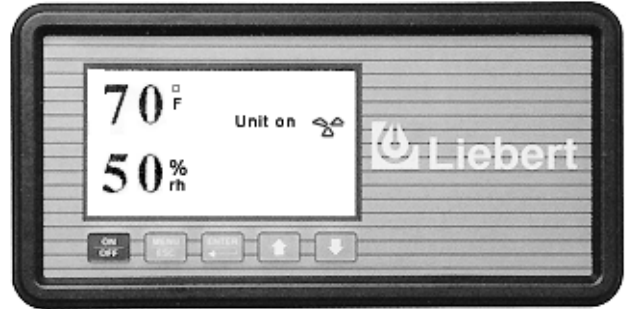

Advanced Microprocessor w/Graphics Control System—Optional. Backlit 240 x 128 dot matrix graphics display.



Graphical Displays (Advanced Graphic Control Only)

- Individual plots of temperature, humidity and the four analog inputs.
- Bar graph plots of individual component run history by hour.
- Floor plan of optional water detection system layout including on alarm.

Status indication of operating modes with current temperature and humidity.

Figure 2 Optional views with Advanced Graphics

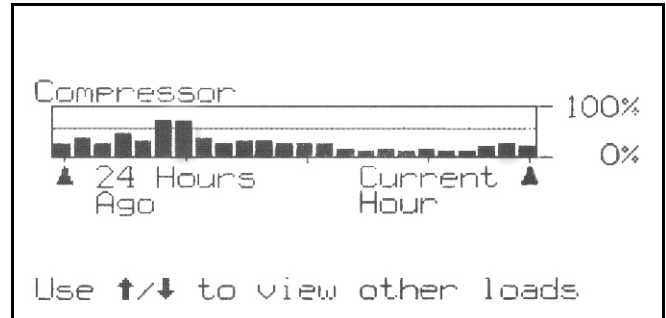

The runtime screen provides data in either tabular or easy-to-read graphic formats.

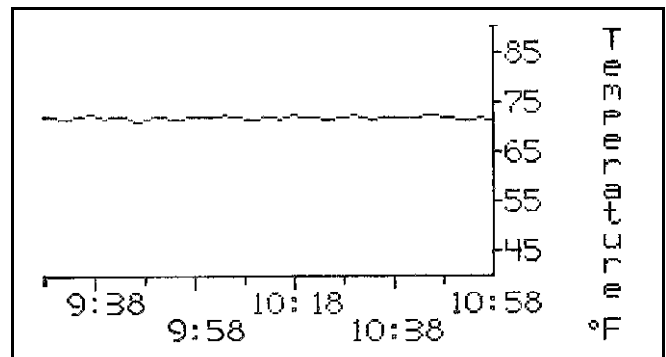

Histograms—historical depictions—of temperature or humidity can be displayed on the screen for analysis. This is especially helpful in tracking the environmental factors of an alarm.

STANDARD FEATURES—ALL SYSTEMS

Cabinet & Frame

The frame, 14 gauge, heliarc welded tubular steel, provides maximum support while steel panels with 1" (25.4mm), 1-1/2 lb. (.68 kg.) insulation protect and quiet the system. The captive, 1/4 turn fasteners allow controlled access for service and are positioned to enhance cabinet appearance.

The top accent panel and left end panel may be opened for service or system monitoring without turning off the unit.

The frame is coated using the autophoretic® process for corrosion protection. All exterior panels are powder coated for optimum durability.

Each panel is available in colors to coordinate with the decor of the space.

Fan Section

The system features quiet, low speed fan assemblies with double width, double inlet blowers, lifetime lubricated and self-aligning ball bearings and factory-certified dynamic balance. The fan motor features an exclusive manual reset internal line-break overload and is mounted on an industrial quality adjustable slide base. The two-belt variable pitch drive may be field adjusted to match this fan speed to the air flow requirements of the data center. Fans are mounted on a fan-deck weldment that can be removed for service. The draw-through design of the fan section supplies even air distribution across the A-Frame coil, controlled bypass-air humidification, static sealing of the filter section and low internal cabinet pressure losses. With the dual belt system, fan operation is ensured even if one of the belts breaks.

High Voltage Panel

The high voltage panel contains contactors, transformers, overloads, and all other exposed high voltage components. Each individual high voltage system component is protected by a separate overcurrent protective device. The entire high voltage panel is enclosed by a safety lock dead front panel. When the top accent panel is opened by operating personnel, these high voltage components remain enclosed by the dead front panel for operator safety.

Infrared Humidifier

High-intensity quartz lamps over the stainless steel humidifier pan permit clean, particle-free vapor to be added to the air within 5 to 6 seconds of the electronic call from the microprocessor control. The quartz lamps provide radiant energy that evaporates water in a pure state, without solids.

The Infrared Humidifier is equipped with an automatic water supply system that significantly reduces cleaning maintenance. This system has an adjustable water-over-feed to prevent mineral precipitation.

A drain valve is provided to easily empty the humidifier pan prior to inspection or servicing. A control valve regulates flow property at water pressures between 5 and 150 psig (34.5 and 1034 kPa) and includes a Y-strainer.

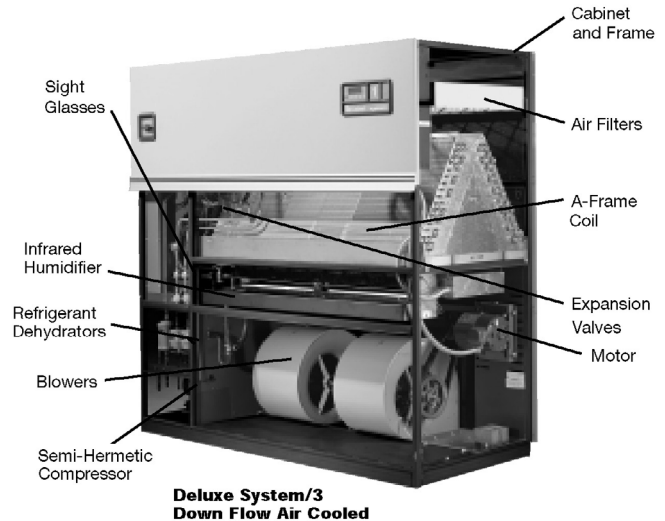

Electric Reheat

The three-stage stainless steel reheat elements are a rigid, fin tubular design that have extended operation life. The reheat has ample capacity to maintain room dry-bulb conditions during a system call for dehumidification.

Three equal stages give a more accurate, controlled response to the requirements of the computer room. The low-watt density, electrically enclosed elements are surrounded by 304 stainless steel tube and fins, reducing sheath temperatures (420°F/ 215.5°C) and eliminating ionization. The three stages of reheat create a noticeable lowering of energy use compared to one- or two-stage systems.

Filters

The standard deep-pleated filter with an efficiency of 20% (based on ASHRAE 52.1) can be changed quickly and easily. Removal is through either end of the system or the top of the unit on downflow models.

Semi-Hermetic Compressors

Two rugged cast-iron semi-hermetic compressors incorporate specific elements designed to maximize operating efficiency and facilitate field servicing. The compressors, mounted on vibration isolators, have built in overloads, oil sight glass, manual reset high pressure switches, pump down low pressure switch, suction line strainer, reversible oil pump for forced feed lubrication and pump down control. Located in a separate compartment, the compressors can be easily monitored in operation without having to interrupt the system. The semi-hermetic compressors stand on a reputation of dependability, and running at a maximum of 1750 rpm, the compressors are not only quiet, but also energy saving.

Table 2 Semi-hermetic compressor EER

Nominal Ton System	Compressor EER*
6 ton	11.7
8 ton	11.7
10 ton	11.7
15 ton	11.7
20 ton	11.6
22 ton	11.7
30 ton	11.0

*Based on ARI Rated Conditions: 130°F SCT, 45°F SST, 15°F Sub-Cooling.

A-Frame Coil

The interwoven arrangement of two direct expansion cooling circuits provides maximum coil area for more precise control of temperature and humidity. With this computer selected coil design, low velocity air passes through both circuits of the coil providing the most effective surface exposure with less turbulence and greater efficiency in the cooling and dehumidifi-

cation process. The Liebert manufactured A-Frame coil is designed for the high sensible heat ratio required for electronic cooling applications. Because of the interwoven circuitry, which has alternating portions of the coil circuited to each of the two compressors, the entire finned area is used for cooling by either compressor. A stainless steel corrosion free condensate drain pan is also provided with the A-Frame coil.

Sight Glasses

Refrigerant line sight glasses serve as a means of quick visual inspection to determine if there is moisture in the system and if the system is properly charged.

Refrigerant Dehydrators

Refrigerant dehydrators assure a moisture-free refrigerant system for extended component life.

Expansion Valves

The externally equalized expansion valves smoothly control refrigerant flow during indoor heat loads and outdoor ambients by controlling evaporator superheat.

Mufflers

Specially engineered mufflers afford a quiet pulsation free refrigeration system.

Safety Controls

Each compressor has a high pressure switch with a manual reset feature for high pressure protection, a low pressure switch for loss of refrigerant charge protection, and a high pressure alarm circuit to visually and audibly warn of high system pressures, allowing corrective action to be taken before a system failure.

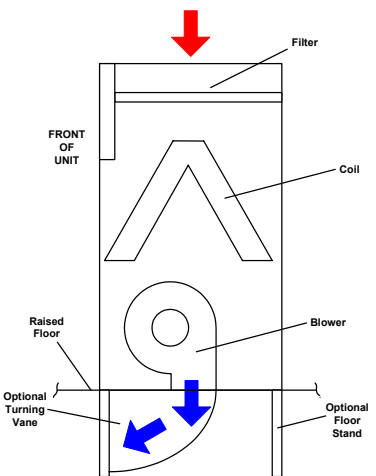

Downflow with optional floor stand and optional turning vane

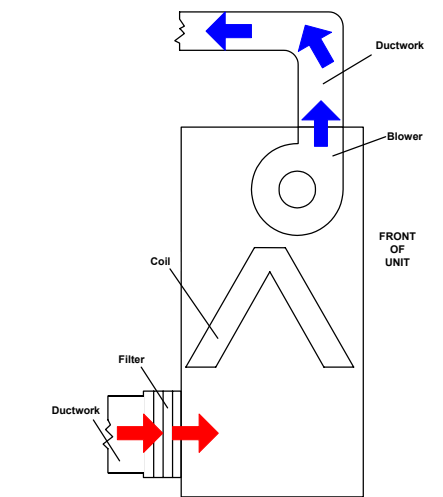

Upflow with rear return and top rear supply—Customer ducted supply and return

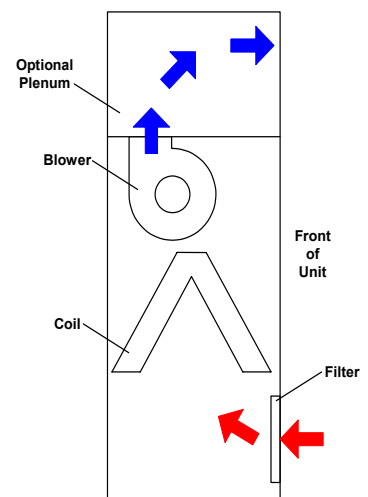

Upflow with front return and top front supply—optional plenum with front discharge grille

STANDARD FEATURES—INDIVIDUAL SYSTEMS

Air Cooled Condenser

The Liebert manufactured low-profile multiple direct drive propeller fan type air cooled condenser utilizes two separate refrigeration circuits.

Each balances the heat rejection of the corresponding compressor. Constructed of aluminum with a copper tube aluminum fin coil, the unit is quiet and corrosion resistant. An integral, factory wired and tested control panel reduces installation time.



Outdoor Air Cooled Condenser With Optional Lee-Temp

Fan Speed—Winter Control

The winter control system features a variable speed motor specifically designed to be used in conjunction with the solid state fan-speed control transducer. These transducers directly sense the head pressure of either of the compressors and varies the speed of the fan to maintain constant condensing temperature and system capacity. Auxiliary fan motors are controlled by ambient thermostats. This system allows for operation at ambient temperatures as low as -20°F (-28.9°C).

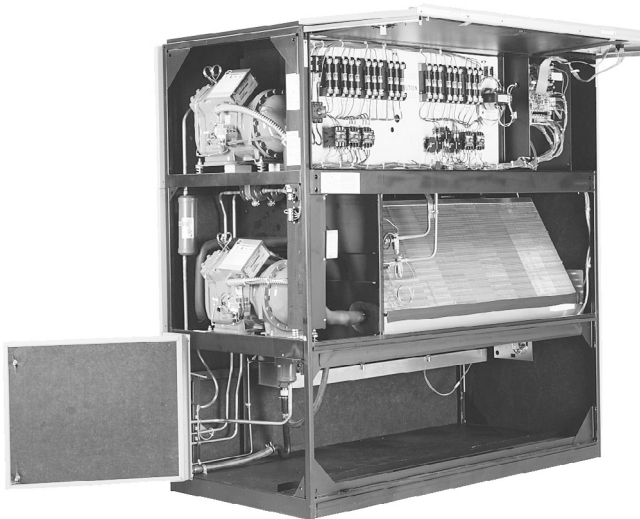

Air Cooled Upflow With Front Return (filters removed)

Water Cooled Condensers

The water cooled condensers are of the heavy duty, shell and tube, counter-flow type with removable heads. Constructed of copper tubes with cast iron heads, they are mechanically cleanable from either side. The shell side of the condensers acts as a receiver and holds refrigerant charge during pump-down.

Regulating Valves

Head pressure operated water regulating valves accurately control the condensing temperature for various entering water pressures and temperatures.

Glycol Cooled Condenser

The Glycol cooled condensers are of the heavy duty, shell and tube counterflow type with removable heads. Constructed of copper tubes with cast iron heads, they are mechanically cleanable from either side. The shell side of the condensers act as a receiver and hold refrigerant charge during pumpdown.

Regulating Valves

Head pressure operated Glycol regulating valves accurately control the condensing temperature for various entering Glycol pressures and temperatures. Each valve has a parallel factory-piped bypass valve.

Glycol Pump

The Glycol system includes a matching centrifugal glycol pump mounted in a weatherproof and vented enclosure.



Glycol Pump Package

Drycooler

The Liebert manufactured drycooler is constructed of aluminum with a copper tube, aluminum fin coil. The low profile design features multiple direct drive propeller type fans, balanced to the heat rejection load. An integral, factory wired and tested control panel reduces installation time.

GLYCOOL

E+E High Energy Efficiency

The Liebert GLYCOOL free cooling system is integrated with a glycol cooled Deluxe System/3. At outdoor temperatures below 35°F/1.6°C (40°F/4.4°C with 6-row Econ-O-Coil), the GLYCOOL System is capable of providing total system capacity.

At outdoor temperatures between 35° and 65°F (1.6° and 18.3°C), the unique modulating valve permits partial cooling of the room.

When cooling is required, the microprocessor activates the three-way modulating valve and circuits glycol (from the heat rejection loop) to the Econ-O-Coil located upstream of the evaporator coil.

The GLYCOOL System contains all the standard features of a glycol cooled system plus the following.

Comparative Temperature Monitor

A solid-state temperature monitor compares computer room air temperature and entering glycol temperature. When air temperature is higher than glycol temperature, the monitor communicates to the microprocessor control that “free-cooling” is available.

GLYCOOL Coil

The GLYCOOL coil is strategically located in the return air stream of the environmental control system. The air is first filtered before entering the coil, and then is either precooled or totally cooled before entering the refrigeration coil. The glycol flow to the coil is controlled by a pre-piped modulating three-way valve.

When supplied with a 45°F (7.2°C) glycol solution, the coil is sufficiently sized to offer the identical cooling capacity as is obtained during the refrigeration cycle of both compressors.

GLYCOOL Three-Way Control Valve

The GLYCOOL Three-Way Control Valve opens full any time the temperature of the glycol solution is below room temperature to take full advantage of all possible free cooling.

As the outdoor ambient drops, the three-way control valve modulates the flow to the GLYCOOL coil, as in a Chilled Water system. It maintains constant temperature in the room and includes operating linkage and electronic motor. Unlike other valves of this nature, there is no over travel linkage or end switches to be adjusted.

Glycol Regulating Valves

Head pressure operated glycol regulating valves accurately control the condensing temperature and system capacity for various entering glycol temperatures. Each valve has three-way action.

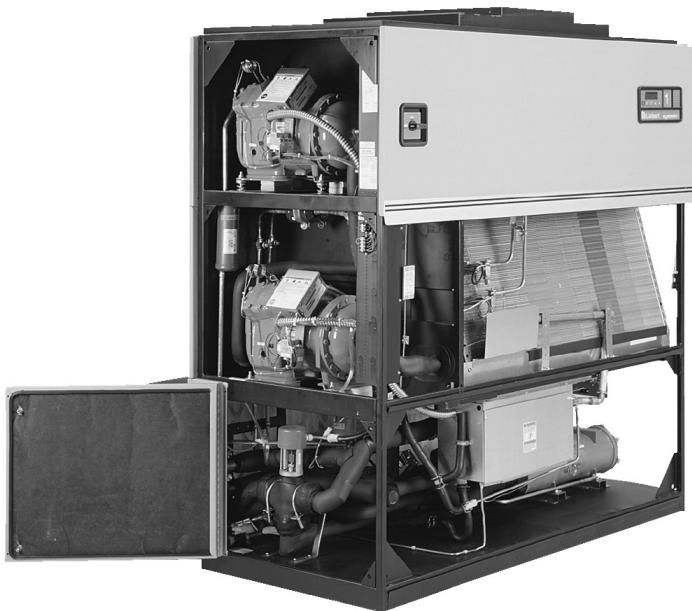

GLYCOOL Upflow With Rear Return



GLYCOOL Downflow

Air Cooled Lee-Temp

The Lee-Temp winter control system's heated receivers permit startup and positive head pressure control at ambient temperatures as low as -30°F (-34.4°C). The Lee-Temp package includes insulated receivers, a pressure relief valve, three-way head pressure control valves, check valves, and rotalock valves for each circuit.

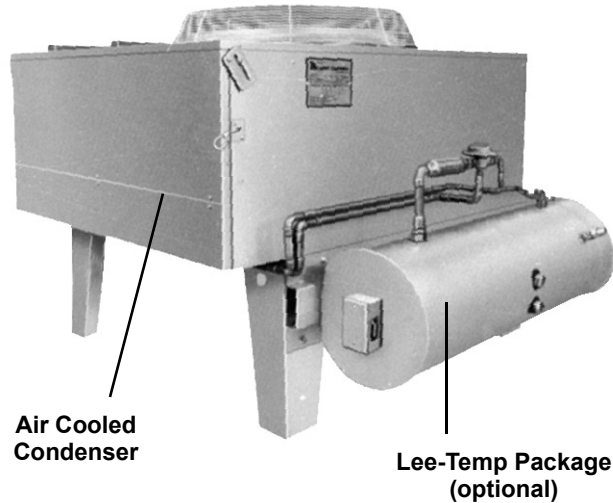

High Rise Building Systems

The Series PB is a line of condensers designed for installations where roof top condenser mounting is impractical. These condensers may be mounted indoors, adjacent to the cooling unit or remote, with ducted condenser air.

Quiet-Line Condensers

Quiet-Line condensers can help your facility meet the strictest noise codes, and do so at less cost than traditional condensers with acoustical shielding.

Complete engineering details are described in General Data Manual SL-10057.

Water Cooled Hot Gas Reheat

The hot gas reheat assembly consists of a three-way directional solenoid operated valve, check valve, and a hot gas heat reclaim coil. When the system is in the dehumidification mode, hot gas reheat will be the first step of heat when called for by the control system.

In addition to refrigerant reheat, the Liebert system is also provided with one stage of electric reheat in the same system. The use of hot gas reheat with electric reheat is economical as well as efficient. (Not available on upflow models.)

High Pressure

The high pressure option for the condenser water circuit consists of a water regulating valve and a shell and tube condenser rated at 300 PSIG (2068 kPa) water pressure. This option is required in applications with large static head pressures.

Regulating Valves

Two water regulating valve options are available: (a) two-way with bypass and (b) three-way.

- a. Two-way with bypass controls condensing temperature and prevents tower pumps from “dead-heading” by providing a bypass gate valve around the regulating valve.
- b. Three-way valves provide accurate control of condensing temperature and thus maintain constant system capacity while also keeping the condenser water flow rate constant.

Glycol & GLYCOOL Cooled

Hot Gas Reheat

The hot gas reheat assembly consists of a three-way directional solenoid operated valve, check valve, and a hot gas heat reclaim coil. When the system is in the dehumidification mode, hot gas reheat will be the first step when called for by the control system.

In addition to refrigerant reheat, the Liebert system can be optionally provided with up to two additional stages of electric heat in the same system. The use of hot gas reheat is economical as well as efficient. (**Note:** Not available on upflow models.)

Dual Pump Package

The dual pump package features two full size glycol pumps, each capable of providing sufficient flow for system operation. A flow switch will sense the loss of flow, should the lead pump fail, and automatically command the standby pump to start. A contact closure is provided to connect to the system alarm configuration.

The complete system includes dual pump housing, pumps, lead-lag switch, and flow switch (for field installation). The dual pump package provides redundancy protecting against costly downtime in the computer room.

High Pressure

The high pressure option for the condenser circuit consists of a 2-way water regulating valve with bypass and a shell and tube condenser rated at 300 PSIG (2068 kPa) water pressure. This option is required in applications with large static heads.

Regulating Valves

Two glycol regulating valve options are available: (a) two-way and (b) three-way.

- a. Two-way valves are head pressure activated to control condensing temperature.
- b. Three-way valves provide accurate control of condensing temperature and thus maintain constant system capacity while also keeping the condenser glycol flow rate constant.

70/30 Cu-Ni Econ-O-Coil

This coil replaces the standard copper tube coil to provide improved resistance to corrosion.

This option must be specified whenever a GLYCOOL or Dual Cooling Source system is applied to a cooling tower loop or other open water system.

High Rise Building Systems

Series PB is a line of drycoolers designed for installations where roof top drycooler mounting is impractical. These drycoolers may be mounted indoors, adjacent to the cooling unit or remote, with ducted drycooler air.

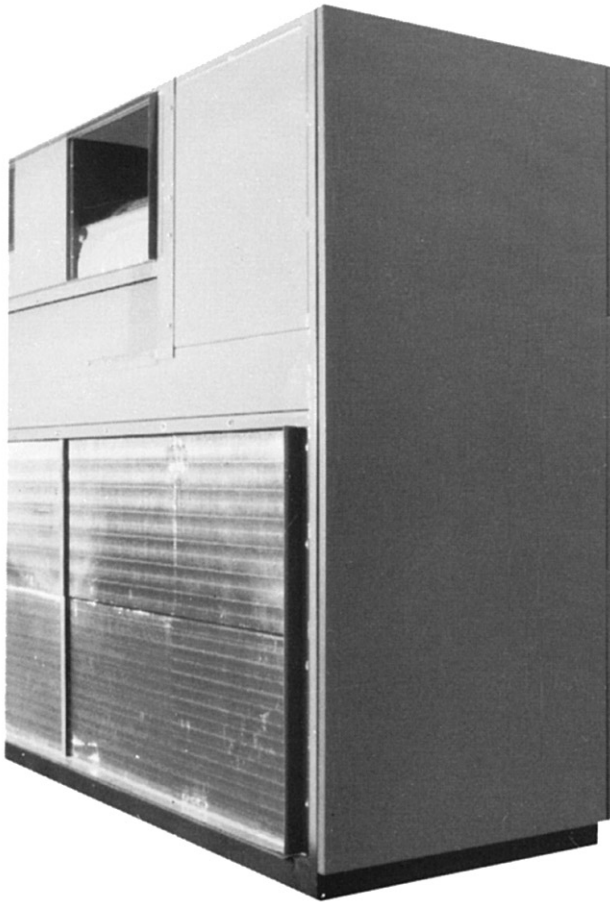

**High Rise Building Systems
(PB Condensers and Drycooler)**

Quiet-Line Drycoolers

Quiet-Line Drycoolers can help your facility meet the strictest noise codes, and do so at less cost than traditional drycoolers with acoustical shielding. Complete engineering details are described in General Data Manual SL-10058.

Four-Step System

E+E High Energy Efficiency

The Liebert four-step cooling system reduces compressor cooling capacity and energy consumption during periods of low room load conditions. This is accomplished by means of a specially designed control system and cylinder unloaders on one head of each of the two semi-hermetic compressors.

As a result, four distinct stages of cooling are activated to more closely respond to changing room conditions.

The first step, which uses the lead compressor with the unloader valve activated, provides 38% of the total unit capacity while using only 25% of the total energy. The second step, which uses both compressors with unloader valves activated, can provide 76% of total system capacity with 50% of the total compressor energy.

Because start-up of each compressor is with the unloader valve activated, initial current surge and wear on the compressor is reduced.

The four-step cooling system can be specified on air, water, and glycol cooled systems from 8 to 30 tons.

GLYCOOL and Dual Cooling Source systems may also be equipped with the four-step feature to achieve maximum energy efficiency.

Dual Cooling Source

E+E High Energy Efficiency

These systems convert an air or water cooled FH model to a dual source cooling system.

With the addition of an Econ-O-Coil, a modulating control valve and a comparative temperature sensor, the unit can function either as a modulating chilled water system or as a compressorized system, or a combination of both. Switchover between the two cooling modes is performed automatically by the microprocessor control and the comparative sensor. This can provide increased redundancy and flexibility to the environmental control system.

OPTIONAL EQUIPMENT—ALL SYSTEMS

High Efficiency Filters

Downflow systems have 4 optional filters available in lieu of the standard 4" 20% filters. 4" 30%, 4" 40-45%, 4" 60-65% or 6" 60-65% filters are available in most models (Efficiency based on

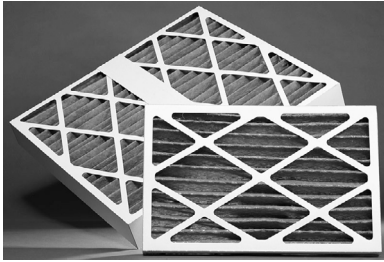

ASHRAE 52.1). 2" 20% pre-filters are also available with any of the above. Upflow systems have 5 optional filters available in lieu of the standard 4" 20% filters. 4" 30%, 4" 40-45%, 4" 60-65%, 4" 80-85% or 4" 90-95% filters are available in all models. 2" 20% pre-filters are also available with any of the above. Larger fan motors are required with many of the optional filter combinations. Consult the factory for specific applications.

High External Static Blower Systems for Upflow Units

Various blower/motor combinations are available to provide standard airflow and cooling capacity with up to 3" of external static pressure.

Heavy Gauge Panels

16 gauge external panels for use on higher esp systems. Extra 1/4 turn fasteners are provided on end panels.

Steam Grid Humidifier

The steam humidifier can be easily adapted into the building's steam system. Contains a stainless steel jacketed manifold to ensure dry steam.

Firestat

The firestat senses return air temperature of the system. Upon sensing high temperatures, the environmental control system is shut down. Required by codes in certain areas.

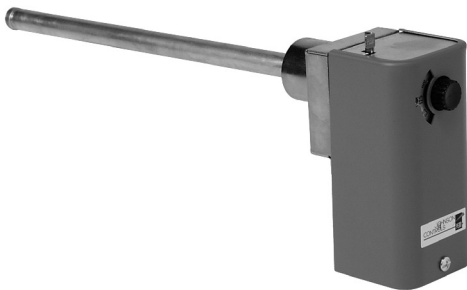

Steam Generating Humidifier

Clean, pure steam is generated in a disposable canister which is complete with supply and drain valves, electronic controls and steam distributor.

The humidifier is provided with an automatic flush cycle to lengthen service life. An indicator on the monitor panel is activated when the canister should be changed. Canister life and humidifier operation are functions of water conductivity.

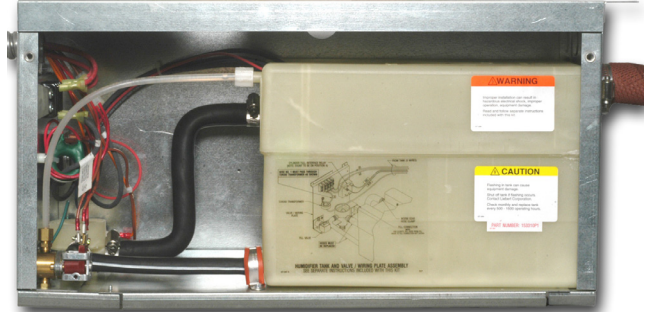

Floor Stand*

Available in heights from 9" to 24" in 3" increments, adjustable $\pm 1-1/2"$. Allows for installation and connection of the system prior to the installation of the raised floor. A modular, field installed turning vane may be specified.



Floor Stand With Turning Vane

Smoke Detector

The smoke detector senses the return air, shuts down the unit upon detection, and sends visual and audible alarm. Dry contacts are available for a remote customer alarm. This smoke detector is not intended to function as, or replace, any room smoke detection system that may be required by local or national codes.

Supervised smoke detectors are also available as an option. Consult factory.

Condensate Pump

The condensate pump is mounted in the bottom of the system and is complete with sump, motor, pump and automatic control. Carries a minimum capacity of 20 feet of head (58 kPa). An optional dual float pump is also available for remote alarm indication.



Hot Water/Steam Reheat*

Controlled by a modulating, two-way valve from the microprocessor control panel, these economical reheats have the capacity to maintain dry bulb conditions when the system is calling for dehumidification. The system is completely pre-piped and includes a modulating control valve and Y-strainer. The reheat coil is constructed of copper tubes and aluminum fins.

Disconnect Switch - Locking

The Locking disconnect switch interlocks with the dead-front panel which cannot be opened until the switch is in the OFF position.



Disconnect Switch: Locking and Non-Locking

Disconnect Switch - Non-Locking

The disconnect operating handle protrudes through the front of the system for easy access.

Plenums for Upflow Units*

Standard heights of 20", 22-3/4" and 34-3/4" (51, 58 and 88cm). They are available with a front discharge grille for air distribution within the installed space, and with a top opening for use as a decorative plenum to conceal ductwork off the blowers.

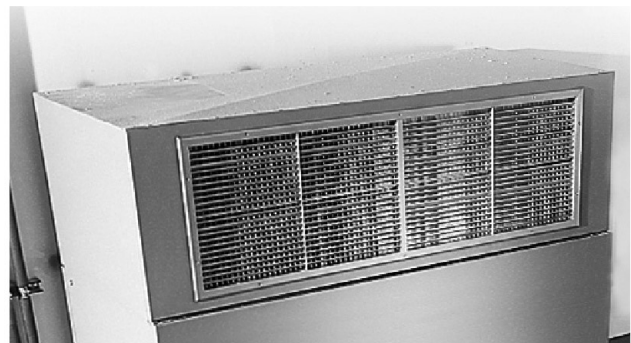

*NOTE

Some options or combinations of options may result in reduced air flow. Consult factory for recommendations.

COMPREHENSIVE MONITORING SYSTEMS—OPTIONAL

You will find a full range of monitoring and control systems, communications modules designed to interface Liebert equipment with a variety of building management systems, plus stand-alone monitoring, control and leak detection devices.

Enterprise Monitoring Systems

SiteScan Web is a comprehensive critical systems monitoring solution dedicated to ensuring reliability through graphics, event management and data extrapolation. The standard Web interface allows users easy access from anywhere at anytime.

- Single- and multi-site applications.
- Event management and unit control.
- Trend and historical data captures and reporting.
- Full ASHRAE BACnet compatibility.
- Java based.
- Windows 2000 and XP compatible.

SiteLink

- Connectivity to building management systems using Modbus and BACnet.

Site I/O

- Integrates sensors and contacts.

Site TPI

- Integrates non-Liebert equipment.

Network Monitoring Systems

The OpenComms™ family of products leverages one-to-one unit connections and your existing network for a comprehensive monitoring solution for distributed equipment.

OpenComms NIC

- Monitoring option available for Liebert precision air conditioning units.
- Web interface for viewing and control.
- Modbus interface for building management systems.
- SNMP interface for network management systems.

OpenComms Nform

- Centralized monitoring of all Liebert SNMP enabled devices.
- Event and alarm management.
- Adaptable and configurable graphical user interface.
- Integration of third-party SNMP enabled devices through custom Liebert services.
- Windows NT, 2000 and XP compatible.

Stand-Alone Monitoring and Leak Detection Solutions

Autonomous microprocessor controlled modules are available to provide supervision, control and remote notification of Liebert equipment. These stand-alone devices include:

Contact Closure Alarm Panels

- Continuously monitor critical support equipment and instantly notify on alarm condition.

Autochangeover Control Panels

- Sequence the operation of multiple environmental units.

Leak Detection Modules

- Provide quick detection and location of hazardous fluid leaks.

Discrete Output Interface Card

- Straightforward way to tie environmental units to a building management system or alarm panel..

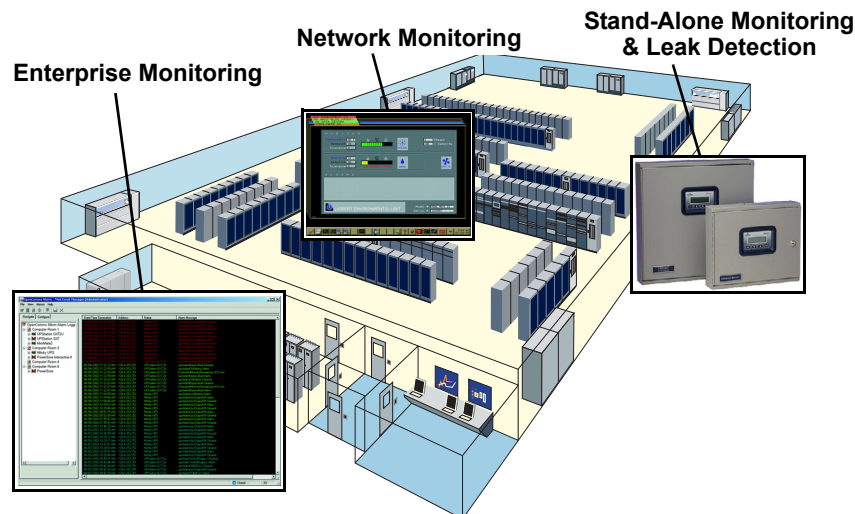

COMPREHENSIVE MONITORING SOLUTIONS—OPTIONAL

SiteScan Web

SiteScan Web is a monitoring solution for critical environments that utilize a facility-view approach. The system enables communications from Liebert environmental and power units—as well as many other pieces of analog or digital equipment to a front end software package that provides monitoring, control and alarm management.

SiteScan monitoring gives you decision making power to effectively manage the equipment that is critical to your business. Designed with flexibility for large, complex systems as well as smaller, single-site facilities, the Liebert SiteScan line of products can provide real-time status and alarms.

SiteLink

The microprocessor-based module provides two-way communication between an existing building management system and up to 12 Liebert units via MOD-Bus or BACnet.

OpenComms Nform

OpenComms Nform centralizes the management of your distributed Liebert network equipment. OpenComms Nform software solution combines full-scale monitoring with the use of the existing network infrastructure—so the cost of dedicated, out-of-band communications cabling is eliminated. It is both scalable and adaptable so it can grow as your systems expand and needs change. OpenComms Nform will monitor any Liebert SNMP device that supports a network interface, such as the OpenComms Web Card and the OpenComms Network Interface Card. Authenticated alarm management and event notification ensures that alarms are detected and acted upon, which allows problems to be quickly resolved.

OpenComms-NIC & OpenComms Web Card

The OpenComms Network Interface Card (OC-NIC) and OpenComms Web Card (OC-Web Card) provide Ethernet connectivity for Liebert equipment. Operating status and alarms are communicated via the network to external systems utilizing industry standard open protocols.

Environmental Discrete Outputs Card

The Environmental Discrete Outputs Card (ENV-DO) provides 16 discrete outputs, corresponding to status and major alarm conditions. These Form-C contact closures provide a straightforward means to connect Liebert Environmental units to Building Management Systems (BMS), I/O or alarm panels.

Remote Contact Monitor (RCM4)

LEDs display customized alarm indication for any dry contact input including alarms for Liebert environmental, power and UPS systems. The RCM4 monitors and displays four dry contact points.

Auto-Changeover Control



Auto-Changeover - RAC2-8

Up to eight environmental units can be automatically and centrally controlled for emergency switching and to balance unit runtime. The AC3 controls two or three units. The RAC2-8 controls two through eight units and has the ability to provide alarm notification to pagers.

Universal Monitor



Universal Monitor Large and Small Enclosures

The Universal Monitor keeps personnel on-site and at remote locations apprised of the status of equipment through local alarming and remote paging services. The panel will interface with anything that closes an electrical contact and any device

with a 4-20mA signal. To improve process efficiency and troubleshooting, the panel tracks data in an alarm log, an event log and a trend log. The Universal Monitor has a local LCD interface and a remote dial-up interface.

Leak Detection



Zone Leak Detection



Area Leak Detection

Zone detectors with cable or single point detectors provide fast and accurate indication of water in your critical space. These systems communicate with your unit or

with a separate monitoring system. Area water detection cable with distance measurement and monitoring protects your entire room. This system quickly and accurately calculates and displays the location of water on the cable, allowing you to promptly find and correct a leak.

Temperature and Humidity Recorder

A seven-day temperature and humidity recorder permits close examination of computer room environment condition and can be used as a permanent record of the environmental control system's operation efficiency. The system includes pens, 100 recording charts; two bottles of recording ink (1 red ink and 1 blue ink).

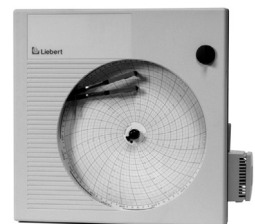

AIR COOLED DATA

Net Capacity Data BTU/HR (kW), Standard Air Volume and Evaporator Fan Motor ***					DH = Downflow; VH = Upflow		
	DH/VH75A	DH/VH114A	DH/VH125A	DH/VH199A	DH/VH245A	DH/VH290A	DH/VH380A
80°F DB, 67°F WB (26.7°C DB, 19.4°C WB) 50% RH							
Total	85,600 (25.1)	123,600 (36.2)	132,800 (38.9)	195,400 (57.2)	247,400 (72.4)	281,400 (82.4)	376,500 (110.2)
Sensible	70,100 (20.5)	96,200 (28.2)	115,000 (33.7)	172,100 (50.4)	209,200 (61.3)	238,700 (69.9)	311,500 (91.2)
75°F DB, 62.5°F WB (23.9°C DB, 16.9°C WB) 50% RH							
Total	79,700 (23.3)	114,500 (33.5)	123,800 (36.2)	182,300 (53.4)	229,800 (67.3)	262,200 (76.8)	350,900 (102.7)
Sensible	67,900 (19.9)	93,200 (27.3)	111,200 (32.6)	166,400 (48.7)	202,100 (59.2)	230,900 (67.6)	301,700 (88.3)
75°F DB, 61 °F WB (23.9°C DB, 16.1 °C WB) 45% RH							
Total	77,700 (22.8)	111,600 (32.7)	124,500 (36.5)	184,500 (54.0)	230,300 (67.4)	262,500 (76.9)	342,400 (100.3)
Sensible	72,600 (21.3)	99,300 (29.1)	124,500 (36.5)	184,500 (54.0)	230,300 (67.4)	262,500 (76.9)	322,600 (94.5)
72°F DB, 60°F WB (22.2°C DB, 15.5°C WB) 50% RH							
Total	76,400 (22.4)	109,700 (32.1)	118,300 (34.6)	174,500 (51.1)	219,700 (64.3)	251,100 (73.5)	336,400 (98.5)
Sensible	66,600 (19.5)	91,400 (26.8)	108,700 (31.8)	162,700 (47.6)	197,700 (57.9)	226,000 (66.2)	295,600 (86.5)
72°F DB, 58.6°F WB (22.2°C DB, 14.8°C WB) 45% RH							
Total	77,300 (22.6)	106,800 (31.3)	120,000 (35.1)	177,600 (52.0)	221,800 (65.0)	253,100 (74.0)	337,000 (98.7)
Sensible	77,300 (22.6)	97,000 (28.4)	120,000 (35.1)	177,600 (52.0)	221,800 (65.0)	253,100 (74.0)	337,000 (98.7)
Net Capacity Data BTU/HR (kW), Optional Air Volume and Evaporator Fan Motor							
75°F DB, 62.5°F WB (23.9°C DB, 16.9°C WB) 50% RH							
Total	86,300 (25.3)	117,800 (34.5)	125,500 (36.7)	188,500 (55.2)	234,400 (68.6)	N/A	N/A
Sensible	86,300 (25.3)	102,600 (30.1)	119,000 (34.8)	188,500 (55.2)	220,000 (64.4)	N/A	N/A
75°F DB, 61°F WB (23.9°C DB, 16.1°C WB) 45% RH							
Total	86,300 (25.3)	119,900 (35.1)	127,900 (37.5)	188,500 (55.2)	238,400 (69.8)	N/A	N/A
Sensible	86,300 (25.3)	119,900 (35.1)	127,900 (37.5)	188,500 (55.2)	238,400 (69.8)	N/A	N/A
72°F DB, 60°F WB (22.2°C DB, 15.5°C WB) 50% RH							
Total	83,100 (24.3)	112,700 (33.0)	123,300 (36.1)	181,800 (53.2)	229,600 (67.2)	N/A	N/A
Sensible	83,100 (24.3)	100,400 (29.4)	123,300 (36.1)	181,800 (53.2)	229,600 (67.2)	N/A	N/A
72°F DB, 58.6°F WB (22.2°C DB, 14.8°C WB) 45% RH							
Total	83,100 (24.3)	115,600 (33.8)	123,300 (36.1)	181,800 (53.2)	229,600 (67.2)	N/A	N/A
Sensible	83,100 (24.3)	115,600 (33.8)	123,300 (36.1)	181,800 (53.2)	229,600 (67.2)	N/A	N/A
Dual Cooling Source-Coil Capacity, Downflow Models ONLY							
75°F DB, 62.57 WB (23.9°C DB, 16.9°C WB) 50% RH, 45°F EWT							
Total	118,900 (34.8)	159,100 (46.6)	187,300 (54.8)	290,000 (84.9)	345,000 (101.0)	N/A	*359,100 (105.1)
Sensible	92,800 (27.2)	125,800 (36.8)	149,800 (43.9)	229,100 (67.8)	272,900 (79.9)	N/A	314,900 (92.2)
Flow Rate-GPM (l/s)	22 (1.4)	28.7 (1.8)	33.1 (2.1)	48.6 (3.1)	59.5 (3.8)	N/A	65.6 (4.1)
Pressure Drop-ft (kPa)	7.3 (21.8)	11.9 (35.5)	15.4 (45.9)	16.7 (49.8)	25.5 (75.8)	N/A	27.8 (82.9)
Fan Section-Downflow models-Variable Pitch, Two (2) Belt Drive Package**							
Standard Air Volume-CFM (CMH)	3350 (5,690)	4650 (7,900)	5650 (9,600)	8400 (14,270)	10,200 (17,330)	12,000 (20,390)	15,200 (25,830)
Standard Fan Motor HP	1.0	1.5	2.0	3.0	5.0	7.5	10
Optional Air Volume-CFM (CMH)	4650 (7,900)	5650 (9,600)	6400 (10,870)	9400 (15,970)	12,000 (20,390)	N/A	N/A
Optional Fan Motor HP	1.5	2.0	3.0	5.0	7.5	N/A	N/A
External Static Pressure inches of water (Pa)	.5 (125)	.5 (125)	.5 (125)	.5 (125)	.5 (125)	.5 (125)	.5 (125)
Number of Fans	2	2	2	2	2	2	3
Fan Section-Upflow models-Variable Pitch, Two (2) Belt Drive Package**							
Standard Air Volume-CFM (CMH)	3350 (5,690)	4650 (7,900)	5650 (9,600)	8400 (14,270)	10,200 (17,330)	12,000 (20,390)	15,200 (25,830)
Standard Fan Motor HP	1.0	2.0	3.0	5.0	7.5	10.0	10.0
Optional Air Volume-CFM (CMH)	4650 (7,900)	5650 (9,600)	6400 (10,870)	9400 (15,970)	12,000 (20,390)	N/A	N/A
Optional Fan Motor HP	2.0	3.0	5.0	5.0	10.0	N/A	N/A
External Static Pressure inches of water (Pa)	.5 (125)	.5 (125)	.5 (125)	.5 (125)	.5 (125)	.5 (125)	.5 (125)
Number of Fans	1	1	1	2	2	2	3
Compressor-Semi-Hermetic (Cast Iron Serviceable)-Refrigerant R-22							
Number of Compressors	2	2	2	2	2	2	2
RPM	1750	1750	1750	1750	1750	1750	1750

*The Econ-O-Coil option on this model will result in a 14,250 CFM (24,211 CMH) unit air flow and 3% sensible capacity reduction.

**Some options or combinations of options may result in reduced air flow-consult factory for recommendations.

***For optional fan motors deduct 2800 BTU/hr per hp over standard motor.

All capacities are nominal values; actual performance will be ±5%.

	DH/VH75A	DH/VH114A	DH/VH125A	DH/VH199A	DH/VH245A	DH/VH290A	DH/VH380A
Evaporator Coil-A-Frame-Copper Tube/Aluminum Fin							
Face Area-Sq. Ft. (m ²)	14.2 (1.32)	14.2 (1.32)	14.2 (1.32)	22.2 (2.06)	22.2 (2.06)	22.2 (2.06)	29.4 (2.73)
Rows of Coil	3	3	4	4	4	4	4
Face Velocity-FPM (m/s)-STD Air Vol.	222 (1.13)	313 (1.60)	384 (1.95)	369 (1.87)	450 (2.3)	531 (2.69)	510 (2.60)
Reheat Section							
Electric Reheat-three (3) Stage, Fin Tubular							
Capacity-BTU/HR (kW)*	36,700 (10)	55,000 (15)	56,300 (15)	93,000 (25)	115,000 (30)	121,500 (30)	126,900 (30)
Steam Reheat-218°F (103.3°C) Steam, 75°F (23.9°C) E.A.T., STD Air Volume-Modulating Control Valve 2-way***							
Capacity BTU/HR (kW)*	83,200 (24.4)	84,500 (24.8)	85,800 (25.1)	108,700 (31.9)	117,500 (34.4)	N/A	N/A
Hot Water Reheat - 180°F (82.2°C) E.W.T., STD CFM, 60°F (15.5°C) E.A.T. - Modulating Control Valve 2-W*** **							
Capacity-BTU (kW)*	58,145 (17.0)	66,435 (19.4)	73,520 (21.5)	121,660 (35.6)	36,815 (40.0)	N/A	N/A
Flow Rate-GPM (l/s)	5 (0.32)	5 (0.32)	5 (0.32)	5 (0.32)	8 (0.51)	N/A	N/A
Pressure Drop-ft (kPa)	10.7 (31.7)	10.7 (31.7)	10.7 (31.7)	6.1 (18.2)	6.1 (18.2)	N/A	N/A
* Includes Fan Motor *** 25 PSI (172.4 kPa) max operating pressure-consult factory for higher pressures operating pressures.							
** Optional 3-way available-consult factory **** 150 PSI (1034.3 kPa) max operating pressure-consult factory for higher pressures.							
Humidifier Section							
Infrared Humidifier							
Capacity lbs/hr. (kg/h)	17.4 (7.9)	17.4 (7.9)	17.4 (7.9)	17.4 (7.9)	22.1 (10.0)	22.1 (10.0)	22.1 (10.0)
kW	6.4	6.4	6.4	6.4	9.6	9.6	9.6
Pan	Stainless	Stainless	Stainless	Stainless	Stainless	Stainless	Stainless
Steam Grid Humidifier-All Models (Standard Selection, 5 PSIG. Steam 14 lbs/hr)							
Supply Steam Pressure-PSIG (kPa)	2 (13.8); 4 (27.6); 5 (34.5); 6 (41.4); 8 (55.2); 10 (68.9)						
Capacity, lbs/hr (kg/h) w/5/32" Orifice	8 (3.6); 12 (5.4); 14 (6.4); 16 (7.3); 19 (8.6); 21 (9.5)						
Steam Generating Humidifier-Water conductivity between 200-500 micromhos is required for ideal operation							
Capacity-lbs/hr (kg/h)	11 (5.0)	11 (5.0)	11 (5.0)	22 (10.0)	22 (10.0)	22 (10.0)	22 (10.0)
kW	3.6	3.6	3.6	7.2	7.2	7.2	7.2
Filter Section-Disposable Type-Nominal Sizes and Quantities							
Downflow Models							
Nominal Size	24x24	24x24	24x24	24x24	24x24	24x24	24x24
Quantity	3	3	3	4	4	4	5
Upflow Models (Front & Rear Return)							
Nominal Size	20x16/20x25	20x16/20x25	20x16/20x25	24x24	24x24	24x24	
Quantity	3/1	3/1	3/1	4	4	4	5
Upflow Models (Bottom Return)							
Nominal Size	24x24	24x24	24x24	24x24	24x24	24x24	24x24
Quantity	3	3	3	4	4	4	5
Condenser (Standard 95°F Ambient)*-Aluminum Cabinet (see Heat Rejection catalog for complete condenser data)							
Model No.	CD*-104	CD*-165	CD*-165	CD*-205	CD*-308	CD*-308	CD*-415
No. of Fans	1	2	2	2	3	3	4
Weight-lbs (kg)* (Net) Condenser only	315 (191)	425 (243)	425 (243)	495 (297)	670 (415)	670 (415)	1025 (530)
Liquid Line Connection Size (OD Copper) Condenser	1/2	5/8	5/8	7/8	1-1/8	1-1/8	1-1/8
Hot Gas Connection Size (OD Copper) Condenser	7/8	7/8	7/8	1-1/8	1-3/8	1-3/8	1-5/8
*Data shown applies to the standard factory manufactured condensers. These may vary in local areas and verification with the Liebert representative is strongly recommended.							
Safety Relief Valve—Lee-Temp Only							
ASME Code Symbol	UV	UV	UV	UV	UV	UV	UV
Setting-psi (kPa)	440 (3034)	440 (3034)	440 (3034)	440 (3034)	440 (3034)	440 (3034)	440 (3034)
Connection Sizes-Deluxe System/3							
Liquid Line-OD Copper* (2/unit)	1/2	1/2	1/2	1/2	5/8	5/8	5/8
Hot Gas Line-OD Copper* (2/unit)	5/8	5/8	5/8	7/8	1-1/8	1-1/8	1-1/8
Infrared Humidifier-OD Copper	1/4	1/4	1/4	1/4	1/4	1/4	1/4
Condensate Drain-FPT	3/4	3/4	3/4	3/4	3/4	3/4	3/4
Steam Reheat-MPT	1/2	1/4	1/2	3/4	3/4	3/4	
Hot Water Reheat-OD Copper	5/8	5/8	5/8	7/8	7/8	-	-
Steam Humidifier-MPT	1/2	1/2	1/2	1/2	1/2	1/2	1/2
Weight-lbs (kg)-Deluxe System/3	1205 (547)	1425 (646)	1440 (653)	1840 (835)	1960 (889)	2025 (919)	2160 (979)

WATER COOLED DATA

Net Capacity Data BTU/HR (kW), Standard Air Volume and Evaporator Fan Motor DH= Downflow VH= Upflow							
	DH/VH86W	DH/VH127W	DH/VH138W	DH/VH219W	DH/VH267W	DH/VH315W	DH/VH412W
80°F DB, 67°F WB (26.7°C DB, 19.4°C WB) 50 % RH							
Total	92,900 (27.2)	135,200 (39.6)	147,600 (43.2)	216,100 (63.3)	269,200 (78.9)	311,000 (91.1)	415,700(121.8)
Sensible	72,800 (21.3)	100,600 (29.5)	120,500 (35.3)	179,600 (52.6)	217,100 (63.6)	249,400 (73.1)	325,900 (95.5)
75°F DB, 62.5°F WB (23.9°C DB, 16.9°C WB) 50% RH							
Total	86,100 (25.2)	124,900 (36.6)	136,500 (40.0)	199,800 (58.5)	247,700 (72.6)	286,900 (84.1)	384,200(112.6)
Sensible	70,500 (20.6)	97,400 (28.5)	116,300 (34.1)	173,300 (50.8)	209,300 (61.3)	240,700 (70.5)	315,000 (92.3)
75°F DB, 61°F WB (23.9°C DB, 16.1°C WB) 45% RH							
Total	83,700 (24.5)	121,200 (35.5)	132,600 (38.9)	199,500 (58.5)	240,700 (70.5)	279,000 (81.7)	374,300(109.7)
Sensible	75,100 (22.0)	103,300 (30.2)	124,000 (36.3)	199,500 (58.5)	223,100 (65.4)	256,600 (75.2)	335,800 (98.4)
72°F DB, 60°F WB (22.2°C DB, 15.5°C WB) 50% RH							
Total	82,100 (24.0)	118,400 (34.7)	130,000 (38.1)	190,500 (55.8)	235,900 (69.1)	273,800 (80.2)	365,800(107.1)
Sensible	69,000 (20.2)	95,100 (27.8)	113,600 (33.3)	169,300 (49.6)	204,400 (59.9)	235,400 (69.0)	308,000 (90.2)
72°F DB, 58.6°F WB (22.2°C DB, 14.8°C WB) 45% RH							
Total	80,000 (23.4)	115,500 (33.8)	130,200 (38.1)	191,700 (56.2)	230,000 (67.4)	265,900 (77.9)	357,000(104.6)
Sensible	73,300 (21.5)	100,800 (29.5)	130,200 (38.1)	191,700 (56.2)	217,600 (63.8)	250,100 (73.3)	327,500 (96.0)
Net Capacity Data BTU/HR (kW), Optional Air Volume and Evaporator Fan Motor							
75°F DB, 62.5°F WB (23.9°C DB, 16.9°C WB) 50% RH							
Total	90,200 (26.4)	128,900 (37.7)	139,100 (40.8)	203,000 (59.5)	253,800 (74.4)	N/A	N/A
Sensible	83,500 (24.5)	107,000 (31.3)	124,300 (36.4)	184,100 (53.9)	227,600 (66.7)	N/A	N/A
75°F DB, 61°F WB (23.9°C DB, 16.1°C WB) 45% RH							
Total	92,900 (27.2)	125,200 (36.7)	140,000 (41.0)	205,200 (60.1)	255,400 (74.8)	N/A	N/A
Sensible	92,900 (27.2)	114,000 (33.4)	140,000 (41.0)	205,200 (60.1)	255,400 (74.8)	N/A	N/A
72°F DB, 60°F WB (22.2°C DB, 15.5°C WB) 50% RH							
Total	85,900 (25.2)	122,900 (36.0)	132,500 (38.8)	193,700 (56.8)	241,600 (70.8)	N/A	N/A
Sensible	81,500 (23.9)	104,600 (30.6)	121,400 (35.6)	179,800 (52.7)	222,000 (65.0)	N/A	N/A
72°F DB, 58.6°F WB (22.2°C DB, 14.8°C WB) 45% RH							
Total	89,300 (26.1)	119,300 (35.0)	134,500 (39.4)	197,200 (57.8)	245,200 (71.8)	N/A	N/A
Sensible	89,300 (26.1)	111,100 (32.5)	134,500 (39.4)	197,200 (57.8)	245,200 (71.8)	N/A	N/A
Dual Cooling Source-Coil Capacity, Downflow Models ONLY							
75°F DB, 62.5°F WB (23.9°C DB, 16.9°C WB) 50% RH. 45°F EWT							
Total	118,900 (34.8)	159,100 (46.6)	187,300 (54.8)	290,000(84.9)	345,000(101.0)	N/A	*359,100(105.1)
Sensible	92,800 (27.2)	125,800 (36.8)	149,800 (43.9)	229,100(67.8)	272,900(79.9)	N/A	314,900(92.2)
Flow Rate-GPM (l/s)	22 (1.4)	28.7 (1.8)	33.1 (2.1)	48.6 (3.1)	59.5 (3.8)	N/A	65.6 (4.1)
Pressure Drop-ft (kPa)	7.3 (21.8)	11.9 (35.5)	15.4 (45.9)	16.7 (49.8)	25.5 (75.8)	N/A	27.8 (82.9)
Fan Section-Downflow Models-Variable Pitch, Two (2) Belt Drive Package **							
Standard Air Volume-CFM (CMH)	3350 (5,690)	4650 (7,900)	5650 (9,600)	8400 (14,270)	10,200(17,330)	12,000(20,390)	15,200(25,830)
Standard Fan Motor HP	1.0	1.5	2.0	3.0	5.0	7.5	10
Optional Air Volume-CFM (CMH)	4650 (7,900)	5650 (9,600)	6400 (10,870)	9400 (15,970)	12,000(20,390)	N/A	N/A
Optional Fan Motor HP	1.5	2.0	3.0	5.0	7.5	N/A	N/A
External Static Pressure inches of water (Pa)	.5 (125)	.5 (125)	.5 (125)	.5 (125)	.5 (125)	.5 (125)	.5 (125)
Number of Fans	2	2	2	2	2	2	3
Fan Section-Upflow Models-Variable Pitch, Two (2) Belt Drive Package **							
Standard Air Volume-CFM (CMH)	3350 (5,690)	4650 (7,900)	5650 (9,600)	8400 (14,270)	10,200(17,330)	12,000(20,390)	15,200 (25,830)
Standard Fan Motor HP	1.0	2.0	3.0	5.0	7.5	10.0	10.0
Optional Air Volume-CFM (CMH)	4650 (7,900)	5650 (9,600)	6400 (10,870)	9400 (15,970)	12,000 (20,390)	N/A	N/A
Optional Fan Motor HP	2.0	3.0	5.0	5.0	10.0	N/A	N/A
External Static Pressure inches of water (Pa)	.5 (125)	.5 (125)	.5 (125)	.5 (125)	.5 (125)	.5 (125)	.5 (125)
Number of Fans	1	1	1	2	2	2	3
Compressor-Semi-Hermetic (Cast Iron Serviceable)-Refrigerant R-22							
Number of Compressors	2	2	2	2	2	2	2
RPM	1750	1750	1750	1750	1750	1750	1750
Evaporator Coil-A-Frame-Copper Tube/Aluminum Fin							
Face Area-Sq. ft. (m ²)	14.2 (1.32)	14.2 (1.32)	14.2 (1.32)	22.2 (2.06)	22.2 (2.06)	22.2 (2.06)	29.38 (2.73)
Rows of Coil	3	3	4	4	4	4	4
Face Velocity-FPM (m/s)-STD Air Vol.	222 (1.13)	313 (1.60)	384 (1.95)	369 (1.87)	450 (2.30)	531 (2.69)	510 (2.60)

*The Econ-O-Coil option on this model will result in a 14250 CFM (24,211 CMH) unit air flow and 3% sensible capacity reduction.

**Some options or combinations of options may result in reduced air flow-consult factory for recommendations.

***For optional fan motors, deduct 2800 BTU/hr per HP over standard motor.

All capacities are nominal values; actual performance will be ±5%.

	DH/VH86W	DH/VH127W	DH/VH138W	DH/VH219W	DH/VH267W	DH/VH315W	DH/VH412W
Reheat Section							
Electric Reheat-three (3) Stage, Fin Tubular							
Capacity-BTU/HR (kW)*	36,700 (10)	55,000 (15)	56,300 (15)	93,000 (25)	115,000 (30)	121,500 (30)	126,900 (30)
Steam Reheat-218°F (103.3°C) Steam, 75°F (23.9°C) E.A.T., STD Air Volume-Modulating Control Valve 2-way****							
Capacity BTU/HR (kW)*	83,200 (24.4)	84,500 (24.8)	85,800(25.1)	108,700 (31.9)	117,500 (34.4)	N/A	N/A
Hot Water Reheat-180°F (82.2°C) E.W.T., 60°F (15.5°C) E.A.T., STD Air Volume-Modulating Control Valve 2-way****							
Capacity-BTU (kW)*	58,145 (17.0)	66,435 (19.4)	73,520 (21.5)	121,660 (35.6)	36,815 (40.0)	N/A	N/A
Flow Rate-GPM (l/s)	5 (0.32)	5 (0.32)	5 (0.32)	5 (0.32)	8 (0.51)	N/A	N/A
Pressure Drop-ft (kPa)	10.7 (31.7)	10.7 (31.7)	10.7 (31.7)	6.1 (18.2)	6.1 (18.2)	N/A	N/A
Hot Gas Reheat/electric Reheat Combination-2 Stage (1 Stage Hot Gas Reheat, 1 Stage Electric)-not Available On Upflow Models							
Hot Gas Capacity-BTU/HR (kW)*	33,500 (9.8)	38,400 (11.2)	39,700 (11.6)	60,100 (17.6)	63,200 (18.5)	69,700 (20.4)	N/A
Electric Capacity-BTU/HR (kW)	11,375 (3.3)	17,065 (5)	17,065 (5)	28,440 (8.3)	34,130 (10)	34,130 (10)	N/A
Total Capacity-BTU/HR (kcal/h)*	44,875 (13.1)	55,465 (16.3)	56,765 (16.6)	88,540 (25.9)	97,330 (28.5)	103,830 (30.4)	N/A
Humidifier Section							
Infrared Humidifier							
Capacity, lbs/hr (kg/h)	17.4 (7.9)	17.4 (7.9)	17.4 (7.9)	17.4 (7.9)	22.1 (10.0)	22.1 (10.0)	22.1 (10.0)
kW	6.4	6.4	6.4	6.4	9.6	9.6	9.6
Pan	Stainless	Stainless	Stainless	Stainless	Stainless	Stainless	Stainless
Steam Grid Humidifier-All Models (Standard Selection, 5 PSIG. Steam 14 lbs./hr.)							
Supply Steam Pressure-PSIG (kPa)	2 (13.8); 4 (27.6); 5 (34.5); 6 (41.4); 8 (55.2); 10 (68.9)						
Capacity, lbs/hr (kg/h) w/5/32" Orifice	8 (3.6); 12 (5.4); 14 (6.4); 16 (7.3); 19 (8.6); 21 (9.5)						
Steam Generating Humidifier-Water conductivity between 200-500 micromhos is required for ideal operation							
Capacity-lbs/hr (kg/h)	11 (5.0)	11 (5.0)	11 (5.0)	22 (10.0)	22 (10.0)	22 (10.0)	22 (10.0)
-kW	3.6	3.6	3.6	7.2	7.2	7.2	7.2
Filter Section-Disposable Type-Nominal Sizes and Quantities							
Downflow Models							
Nominal Size	24x24	24x24	24x24	24x24	24x24	24x24	24x24
Quantity	3	3	3	4	4	4	5
Upflow Models (Front & Rear Return)							
Nominal Size	20x16/20x25	20x16/20x25	20x16/20x25	24x24	24x24	24x24	24x24
Quantity	3/1	3/1	3/1	4	4	4	5
Water Regulating Valves-Single Seated, Head Pressure Controlled							
Size-inches	1	1	1	1	1-1/4	1-1/4	1-1/4
Condenser Water Requirements (Maximum design water pressure 346 ft (1034 kPa) High pressure available as an option.) Based on 2-way WRV w/105° SCT							
THR-BTU/HR (kw) @ 75°F 50% RH	104,500 (30.0)	154,100 (44.4)	165,800(48.6)	240,100 (70.4)	302,000 (88.5)	351,500(103.0)	477,800(140.0)
65°F (18.3°C) EWT-GPM (l/s)	5.9 (0.8)	10.5 (1.03)	11.6 (0.73)	18.8 (1.19)	18.9 (1.19)	25.1 (1.58)	31.4 (2.0)
Pressure Drop-ft (kPa)	.9 (3.0)	2.7 (8.3)	3.3 (9.9)	6.4 (19.1)	3.5 (10.4)	6.0 (17.9)	9.1 (27.1)
75°F (23.9°C) EWT-GPM (l/s)	9.0 (0.6)	15.9 (1.0)	17.8 (1.1)	29.4 (1.9)	31.3 (2.0)	39.7 (2.5)	45.3 (2.9)
Pressure Drop- ft (kPa)	2.1 (6.3)	5.9 (17.6)	7.2 (21.5)	39.4 (2.5)	9.1 (27.2)	14.2 (42.4)	18.1 (54.0)
85° (29.4°C) EWT-GPM (l/s) Based on Single-Seated 2-Way Water Regulating Valve with Bypass & 110°F (43.3°C) SCT	11.6 (0.7)	20.7 (1.3)	23.3 (1.5)	39.4 (2.5)	40.7 (2.6)	52.4 (3.3)	58.7 (3.7)
Pressure Drop- ft (kPa)	3.2 (9.5)	9.5 (28.1)	11.8 (35.2)	25.4 (75.8)	14.9 (44.5)	23.9 (71.3)	29.6 (88.3)
Safety Relief Valve - Lee Temp Only							
ASME Code Symbol	UV	UV	UV	UV	UV	UV	UV
Setting-psi (kPa)	440 (3034)	440 (3034)	440 (3034)	440 (3034)	440 (3034)	440 (3034)	440 (3034)
Connection Sizes-Deluxe System/3							
Condenser Water-OD Copper (2/unit)	1-5/8	1-5/8	1-5/8	2-1/8	2-1/8	2-1/8	2-1/8
Infrared Humidifier-OD Copper	1/4	1/4	1/4	1/4	1/4	1/4	1/4
Condensate Drain-FPT	3/4	3/4	3/4	3/4	3/4	3/4	3/4
Steam Reheat-MPT	1/2	1/2	1/2	3/4	3/4	-	-
Hot Water Reheat-OD Copper	5/8	5/8	5/8	7/8	7/8	-	-
Steam Humidifier-MPT	1/2	1/2	1/2	1/2	1/2	1/2	1/2
Weight-lbs (kg)-Deluxe System/3	1455 (660)	1675 (760)	1690 (767)	2110 (957)	2280 (1034)	2345 (1064)	2500 (1134)

GLYCOL COOLED DATA

Net Capacity Data BTU/HR (KW), Standard Air Volume and Evaporator Fan Motor ***** DH= Downflow VH= Upflow							
	DH/VH72G	DH/VH110G	DH/VH116G	DH/VH192G	DH/VH240G	DH/VH265G	DH/VH363G
80°F DB, 67°F WB (26.7°C DB, 19.4°C WB) 50% RH							
Total	81,300 (23.8)	116,100 (34.0)	124,100 (36.4)	186,100 (54.5)	231,900 (67.9)	267,900 (78.5)	364,400 (106.8)
Sensible	68,600 (20.1)	93,500 (27.4)	108,700 (31.8)	168,800 (49.5)	203,600 (59.7)	233,800 (68.5)	307,100 (90.0)
75°F DB, 62.5°F WB (23.9°C DB, 16.9°C WB) 50% RH							
Total	76,100 (22.3)	108,200 (31.7)	115,900 (34.0)	173,800 (50.9)	216,100 (63.3)	250,200 (73.3)	340,700 (99.8)
Sensible	66,500 (19.5)	90,600 (26.5)	105,100 (30.8)	163,000 (47.8)	196,700 (57.6)	226,200 (66.3)	297,700 (87.2)
75°F DB, 61°F WB (23.9°C DB, 16.1°C WB) 45% RH							
Total	76,800(22.5)	105,500 (30.9)	117,400 (34.4)	176,700 (51.8)	218,400 (64.0)	252,000 (73.8)	340,600 (99.8)
Sensible	76,800(22.5)	96,700 (28.3)	117,400 (34.4)	176,700 (51.8)	218,400 (64.0)	252,000 (73.8)	340,600 (99.8)
72°F DB, 60°F WB (22.2°C DB, 15.5°C WB) 50% RH							
Total	72,800 (21.3)	103,600 (30.3)	110,900 (32.5)	170,600 (50.0)	207,100 (60.7)	240,000 (70.3)	327,000 (95.8)
Sensible	65,100 (19.1)	88,800 (26.0)	102,800 (30.1)	170,600 (50.0)	192,500 (56.4)	221,400 (64.9)	291,700 (85.5)
72°F DB, 58.6°F WB (22.2°C DB, 14.8°C WB) 45% RH							
Total	74,100 (21.7)	101,400 (29.7)	113,300 (33.2)	170,600 (50.0)	210,600 (61.7)	243,300 (71.3)	328,900 (96.4)
Sensible	74,100 (21.7)	94,700 (27.7)	113,300 (33.2)	170,600 (50.0)	210,600 (61.7)	243,300 (71.3)	328,900 (96.4)
Net Capacity Data BTU/HR (kW), Optional Air Volume and Evaporator Fan Motor							
75°F DB, 62.5°F WB (23.9°C DB, 16.9°C WB) 50% RH							
Total	82,300 (24.1)	111,000 (32.5)	120,400 (35.3)	180,600 (52.9)	225,300 (66.0)	N/A	N/A
Sensible	82,300 (24.1)	100,000 (29.3)	120,400 (35.3)	180,600 (52.9)	225,300 (66.0)	N/A	N/A
75°F DB, 61°F WB (23.9°C DB, 16.1°C WB) 45% RH							
Total	82,300 (24.1)	113,800 (33.3)	120,400 (35.3)	180,600 (52.9)	225,300 (66.0)	N/A	N/A
Sensible	82,300 (24.1)	113,800 (33.3)	120,400 (35.3)	180,600 (52.9)	225,300 (66.0)	N/A	N/A
72°F DB, 60°F WB (22.2°C DB, 15.5°C WB) 50% RH							
Total	79,200 (23.2)	106,400 (31.2)	116,200 (34.0)	174,400 (51.1)	217,400 (63.7)	N/A	N/A
Sensible	79,200 (23.2)	97,800 (28.6)	116,200 (34.0)	174,400 (51.1)	217,400 (63.7)	N/A	N/A
72°F DB, 58.6°F WB (22.2°C DB, 14.8°C WB) 45% RH							
Total	79,200 (23.2)	109,700 (32.1)	116,200 (34.0)	174,400 (51.1)	217,400 (63.7)	N/A	N/A
Sensible	79,200 (23.2)	109,700 (32.1)	116,200 (34.0)	174,400 (51.1)	217,400 (63.7)	N/A	N/A
Fan Section-Downflow Models-Variable Pitch, Two (2) Belt Drive Package*****							
Air Volume-CFM (CMH)	3350 (5,690)	4650 (7,900)	5650 (9,600)	8400 (14,270)	10,200 (17,330)	12,000 (20,390)	15,200 (25,830)
Fan Motor HP	1.0	1.5	2.0	3.0	5.0	7.5	10
Optional Air Volume-CFM (CMH)	4650 (7,900)	5650 (9,600)	6400 (10,870)	9400 (15,970)	12,000 (20,390)	N/A	N/A
Optional Fan Motor HP	1.5	2.0	3.0	5.0	7.5	N/A	N/A
Ext. Static Press-inches of water (Pa)	.5 (125)	.5 (125)	.5 (125)	.5 (125)	.5 (125)	.5 (125)	.5 (125)
Number of Fans	2	2	2	2	2	2	3
Fan Section-Upflow Models-Variable Pitch, Two (2) Belt Drive Package **							
Standard Air Volume-CFM (CMH)	3350 (5,690)	4650 (7,900)	5650 (9,600)	8400 (14,270)	10,200(17,330)	12,000(20,390)	15,200 (25.830)
Standard Fan Motor HP	1.0	2.0	3.0	5.0	7.5	10.0	10.0
Optional Air Volume-CFM (CMH)	4650 (7,900)	5650 (9,600)	6400 (10,870)	9400 (15,970)	12,000 (20,390)	N/A	N/A
Optional Fan Motor HP	2.0	3.0	5.0	5.0	10.0	N/A	N/A
External Static Pressure inches of water (Pa)	.5 (125)	.5 (125)	.5 (125)	.5 (125)	.5 (125)	.5 (125)	.5 (125)
Number of Fans	1	1	1	2	2	2	3
Compressor-Semi-Hermetic (Cast Iron Serviceable)-Refrigerant R-22							
Number of Compressors	2	2	2	2	2	2	2
RPM	1750	1750	1750	1750	1750	1750	1750
Evaporator Coil-A-Frame-Copper Tube/Aluminum Fin							
Face Area-Sq. Ft. (m ²)	14.2 (1.32)	14.2 (1.32)	14.2 (1.32)	22.2 (2.06)	22.2 (2.06)	22.2 (2.06)	29.4 (2.73)
Rows of Coil	3	3	4	4	4	4	4
Face Velocity-FPM (m/s)-STD Air Vol.	222 (1.13)	313 (1.60)	383 (1.95)	369 (1.87)	455 (2.32)	540 (2.75)	510 (2.60)
Reheat Section							
Electric Reheat-3 Stage, Fin Tubular							
Capacity-BTU/HR (kW)*	36,700 (10)	55,000 (15)	56,300 (15)	93,000 (25)	115,000 (30)	121,500 (30)	126,900 (30)
Steam Reheat-218°F (103.3°C) Steam, 75°F (23.9°C) E.A.T., STD Air Volume-Modulating Control Valve 2-way***							
Capacity-BTU/HR (kW)*	83,200 (24.4)	84,500 (24.8)	85,800 (25.1)	108,700 (31.9)	117,500 (34.4)	N/A	N/A

* Includes Fan Motor

** Optional 3-way valve available.

*** 25 PSI (172.4 kPa) max operating pressure-consult factory for higher pressures.

**** 150 PSI (1034.3 kPa) max operating pressure-consult factory for higher pressures.

All capacities are nominal values; actual performance will be ±5%.

***** Some options or combinations of options may result in reduced air flow-consult factory for recommendations.

***** For optional fan motors deduct 2800 BTU/hr per hp over standard motor.

Reheat Section (Continued)	DH/VH72G	DH/VH110G	DH/VH116G	DH/VH192G	DH/VH240G	DH/VH265G	DH/VH363G
Hot Water Reheat-180°F (82.2°C) E.W.T., 60°F (15.5°C) E.A.T., STD Air Volume-Modulating Control Valve 2-way****							
Capacity-BTU (kW)*	58,145 (17.0)	66,435 (19.4)	73,520 (21.5)	121,660 (35.6)	36,815 (40.0)	N/A	N/A
Flow Rate-GPM (l/s)	5 (0.32)	5 (0.32)	5 (0.32)	5 (0.32)	8 (0.51)	N/A	N/A
Pressure Drop-ft (kPa)	10.7 (31.7)	10.7 (31.7)	10.7 (31.7)	6.1 (18.2)	6.1 (18.2)	N/A	N/A
Hot Gas Reheat-Not Available on Upflow Models							
Hot Gas Capacity-BTU/HR (kW)*	39,100 (11.5)	59,000 (17.3)	61,300 (18.0)	92,900 (27.2)	98,000 (28.7)	104,500 (30.6)	N/A
Humidifier Section							
Infrared Humidifier-Stainless Pan							
Capacity Lbs. Per Hr. (kg/h)	17.4 (7.9)	17.4 (7.9)	17.4 (7.9)	17.4 (7.9)	22.1 (10.0)	22.1 (10.0)	22.1 (10.0)
kW	6.4	6.4	6.4	6.4	9.6	9.6	9.6
Steam Grid Humidifier-All Models (Standard Selection, 5 PSIG. Steam 14 lbs./hr.)							
Supply Steam Pressure-PSIG (kPa)	2 (13.8); 4 (27.6); 5 (34.5); 6 (41.4); 8 (55.2); 10 (68.9)						
Capacity, lbs/hr (kg/h) w/5/32" orifice	8 (3.6); 12 (5.4); 14 (6.4); 16 (7.3); 19 (8.6); 21 (9.5)						
Steam Generating Humidifier-Water conductivity between 200-500 micromhos is required for ideal operation							
Capacity-lbs/hr (kg/h)	11 (5.0)	11 (5.0)	11 (5.0)	22 (10.0)	22 (10.0)	22 (10.0)	22 (10.0)
Capacity-lbs/hr (kg/h)	3.6	3.6	3.6	7.2	7.2	7.2	7.2
Filter Section-Disposable Type-Nominal Sizes and Quantities							
Downflow Models							
Nominal Size	24x24	24x24	24x24	24x24	24x24	24x24	24x24
Quantity	3	3	3	4	4	4	5
Upflow Models (Front & Rear Return)							
Nominal Size	20x16/20x25	20x16/20x25	20x16/20x25	24x24	24x24	24x24	24x24
Quantity	3/1	3/1	3/1	4	4	4	5
Safety Relief Valve - Lee Temp Only							
ASME Code Symbol	UV	UV	UV	UV	UV	UV	UV
Setting-psi (kPa)	440 (3034)	440 (3034)	440 (3034)	440 (3034)	440 (3034)	440 (3034)	440 (3034)
Drycooler Aluminum Cabinet (Standard Selection 95°F Ambient)* See Heat Rejection Catalog for complete drycooler data.							
Model No.	D_-112	D_-174	D_-174	D_-260	D_-310	D_-350	D_-466
No. of Fans	1	2	2	3	3	3	4
Approx. Weight-lbs. (kg)	470 (213)	605 (274)	605 (274)	826 (375)	886 (402)	946 (429)	1250 (567)
Expansion Tank-gal (l)	8.8 (33)	8.8 (33)	8.8 (33)	8.8 (33)	8.8 (33)	8.8 (33)	8.8 (331)
Pipe Connection Size (in.) (FPT)	2	2	2	2	2	2	2-1/2
Specifications are those of Liebert manufactured systems. These may vary in local areas and verification with the Liebert representative is strongly recommended.							
Glycol Pumps-Standard Selection (1 per unit, standard)							
Horsepower	1-1/2	1-1/2	1-1/2	2	3	3	5
Flow Rate-G.P.M. (l/s)	28 (1.76)	32 (2.00)	38 (2.40)	54 (3.40)	67 (4.22)	67 (4.22)	78 (4.92)
Total Head Pressure-Ft. of water (kPa)	80 (239.2)	77 (230.2)	72 (215.3)	71 (212.3)	95 (284.0)	95 (284.0)	115 (343.8)
Suction Size-FPT*	1-1/4	1-1/4	1-1/4	1-1/4	1-1/2	1-1/2	1-1/2
Discharge Size-FPT*	3/4	3/4	3/4	3/4	1	1	1-1/4
Sizes for primary vendor will vary according to source of supply.							
Connection Sizes-Deluxe System/3							
Glycol Condenser-OD Copper	1-5/8	1-5/8	1-5/8	2-1/8	2-1/8	2-1/8	2-1/8
Infrared Humidifier-OD Copper	1/4	1/4	1/4	1/4	1/4	1/4	1/4
Condensate Drain-FPT	3/4	3/4	3/4	3/4	3/4	3/4	3/4
Steam Reheat-MPT	1/2	1/2	1/2	3/4	3/4	-	-
Hot Water Reheat-OD Copper	5/8	5/8	5/8	7/8	7/8	-	-
Steam Humidifier-MPT	1/2	1/2	1/2	1/2	1/2	1/2	1/2
Pressure Drops (Based on 40% Ethylene Glycol)							
Internal Glycol Volume-gal.* (l)	2.0 (7.5)	2.0 (7.5)	2.5 (9.5)	4.5 (17.0)	5.5 (21.0)	5.5 (21.0)	6.3 (24.1)
Unit Pressure Drop-Ft. of water (kPa)	11.6 (34.6)	12.7 (37.9)	17.3 (51.6)	18.6 (55.5)	25.5 (76.1)	25.5 (76.1)	33.0 (98.5)
Drycooler Pressure Drop-Ft. of water (kPa)	8.2 (24.5)	10.7 (31.9)	14.7 (43.9)	12.1 (36.1)	11.2 (33.4)	16.2 (48.3)	12.9 (38.5)
Weight-lbs. (kg)-Deluxe System/3	1455 (660)	1685 (764)	1700 (771)	2130 (966)	2300 (1043)	2365 (1073)	2530 (1148)

*Approximate

GLYCOOL DATA

Net Capacity Data BTU/HR (kW) Downflow Models DE = Downflow VE = Upflow						
	DE/VE72G	DE/VE110G	DE/VE116G	DE/VE192G	DE/VE240G	DE/VE363G
80°F DB, 67°F WB (26.7°C DB, 19.4°C WB) 50% RH						
Total	81,300 (23.8)	116,100 (34.0)	124,100 (36.4)	186,100 (54.5)	231,900 (67.9)	364,400 (106.8)
Sensible	68,600 (20.1)	93,500 (27.4)	108,700 (31.8)	168,800 (49.5)	203,600 (59.7)	307,100 (90.0)
75°F DB, 62.5°F WB (23.9°C DB, 16.9°C WB) 50% RH						
Total	76,100 (22.3)	108,200 (31.7)	115,900 (34.0)	173,800 (50.9)	216,100 (63.3)	340,700 (99.8)
Sensible	66,500 (19.5)	90,600 (26.5)	105,100 (30.8)	163,000 (47.8)	196,700 (57.6)	297,700 (87.2)
75°F DB, 61°F WB (23.9°C DB, 16.1°C WB) 45% RH						
Total	76,800(22.5)	105,500 (30.9)	117,400 (34.4)	176,700 (51.8)	218,400 (64.0)	340,600 (99.8)
Sensible	76,800(22.5)	96,700 (28.3)	117,400 (34.4)	176,700 (51.8)	218,400 (64.0)	340,600 (99.8)
72°F DB, 60°F WB (22.2°C DB, 15.5°C WB) 50% RH						
Total	72,800 (21.3)	103,600 (30.3)	110,900 (32.5)	170,600 (50.0)	207,100 (60.7)	327,000 (95.8)
Sensible	65,100 (19.1)	88,800 (26.0)	102,800 (30.1)	170,600 (50.0)	192,500 (56.4)	291,700 (85.5)
72°F DB, 58.6°F WB (22.2°C DB, 14.8°C WB) 45% RH						
Total	74,100 (21.7)	101,400 (29.7)	113,300 (33.2)	170,600 (50.0)	210,600 (61.7)	328,900 (96.4)
Sensible	74,100 (21.7)	94,700 (27.7)	113,300 (33.2)	170,600 (50.0)	210,600 (61.7)	328,900 (96.4)
Standard Econ-O-Coil Sensible Cooling Capacity Data-BTU/HR (kW) DE Models (Based on 40% Ethylene glycol)						
75°F DB, 62.5°F WB (23.9°C DB, 16.9°C WB) 45°F (7.2°C) EGT	68,500 (20.1) (3 rows)	87,300 (25.6) (3 rows)	104,000 (30.5) (4 rows)	172,900 (50.6) (4 rows)	214,700 (62.9) (4 rows)	296,900 (86.9) (4 rows)
Six (6) Row Econ-O-Coil Sensible Cooling Capacity Data-BTU/HR (kW) DE Models Only (Based on 40% Ethylene Glycol)						
75°F DB, 62.5°F WB (23.9°C DB, 16.9°C WB) 50°F (10°C) EGT	82,800 (24.2)	110,700 (32.4)	133,600 (39.1)	205,400 (60.1)	253,900 (74.3)	N/A
Evaporator Coil-A-Frame Copper Tube/Aluminum Fin-Downflow Models (DE)						
Face Area-Sq. Ft. (m ²)	14.2 (1.32)	14.2 (1.32)	14.2 (1.32)	22.2 (2.06)	22.2 (2.06)	29.4 (2.73)
Rows of Coil	3	3	4	4	4	4
Face Velocity-FPM (m/s)	222 (1.13)	313 (1.60)	384 (1.95)	369 (1.87)	450 (2.30)	478 (2.42)
Fan Section-Downflow Models-Variable Pitch, Two (2) Belt Drive Package*						
Air Volume-CFM (CMH)	3350 (5,690)	4650 (7,900)	5650 (9,600)	8400 (14,270)	10,200 (17,330)	14,250 (24,210)
Ext. Static Press-inches of water (Pa)	.5 (125)	.5 (125)	.5 (125)	.5 (125)	.5 (125)	.5 (125)
Fan Motor HP	1.5	2.0	3.0	5.0	7.5	10
Number of Fans	2	2	2	2	2	3
Net Capacity Data BTU/HR (kW)-Upflow Models (VE) **						
80°F DB, 67°F WB (26.7°C DB, 19.4°C WB) 50% RH						
Total	84,400 (24.7)	122,100 (35.8)	126,300 (37.0)	186,100 (54.5)	231,900 (67.9)	361,900 (106.0)
Sensible	72,000 (21.1)	101,000 (29.6)	113,500 (33.2)	168,800 (49.5)	203,600 (59.7)	297,200 (87.0)
75°F DB, 62.57 WB (23.9°C DB, 16.9°C WB) 50% RH						
Total	78,800 (23.1)	114,100 (33.4)	117,800 (34.5)	173,800 (50.9)	216,100 (63.3)	337,900 (99.0)
Sensible	69,700 (20.4)	98,000 (28.7)	109,600 (32.1)	163,000 (47.8)	196,700 (57.6)	288,200 (84.4)
75°F DB, 61°F WB (23.9°C DB, 16.1°C WB) 45% RH						
Total	79,100 (23.2)	111,100 (32.5)	119,700 (35.1)	176,700 (51.8)	218,400 (64.0)	329,900 (96.6)
Sensible	79,100 (23.2)	104,600 (30.6)	119,700 (35.1)	176,700 (51.8)	218,400 (64.0)	308,100 (90.2)
72°F DB, 60°F WB (22.2°C DB, 15.5°C WB) 50% RH						
Total	75,600 (22.1)	109,200 (32.0)	115,500 (33.8)	170,600 (50.0)	207,100 (60.7)	324,300 (95.0)
Sensible	68,300 (20.0)	95,900 (28.1)	115,500 (33.8)	170,600 (50.0)	192,500 (56.4)	282,600 (82.7)
72°F DB, 58.6°F WB (22.2°C DB, 14.8°C WB) 45% RH						
Total	76,300 (22.3)	109,400 (32.0)	115,500 (33.8)	170,600 (50.0)	210,600 (61.7)	324,400 (95.0)
Sensible	76,300 (22.3)	109,400 (32.0)	115,500 (33.8)	170,600 (50.0)	210,600 (61.7)	324,400 (95.0)
Standard Econ-O-Coil Sensible Cooling Capacity Data-BTU/HR (kW) VE Models Only (Based on 40% Ethylene glycol)						
75°F DB, 62.57 WB (23.9°C DB, 16.9°C WB) 45°F (7.2°C) EGT	69,800 (20.4)	90,900 (26.6)	109,200 (32.0)	159,600 (46.7)	193,900 (56.8)	280,800 (82.2)
Evaporator Coil-A-Frame Copper Tube/Aluminum Fin-Upflow Models (VE)						
Face Area-Sq. Ft. (m ²)	15.25 (1.42)	15.25 (1.42)	15.25 (1.42)	22.2 (2.06)	22.2 (2.06)	29.4 (2.73)
Rows of Coil	4	4	4	4	4	4
Face Velocity-FPM (m/s)	207 (1.05)	292 (1.49)	357 (1.82)	369 (1.88)	450 (2.30)	478 (2.42)
Fan Section-Upflow Models-Variable Pitch, Two (2) Belt Drive Package*						
Air Volume-CFM (CMH)	3350 (5,690)	4650 (7,900)	5650 (9,600)	8400 (14,270)	10,200 (17,330)	14,250 (24,210)
Ext. Static Press-inches of water (Pa)	.5 (125)	.5 (125)	.5 (125)	.5 (125)	.5 (125)	.5 (125)
Fan Motor HP	1.0	2.0	5.0	5.0	7.5	10.0
Number of Fans	1	1	1	2	2	3

* Some options or combinations of options may result in reduced air flow-consult factory for recommendations.

** For optional fan motors deduct 2800 BTU/hr per hp over standard motor.

All capacities are nominal values; actual performance will be ±5%.

	DE/VE72G	DE/VE110G	DE/VE116G	DE/VE192G	DE/VE240G	DE/VE363G
Compressor Section						
Compressor-Semi-Hermetic (Cast Iron Serviceable)						
Number of Compressors	2	2	2	2	2	2
Refrigerant	R-22	R-22	R-22	R-22	R-22	R-22
RPM	1750	1750	1750	1750	1750	1750
Electric Reheat-Three (3) Stage, Fin Tubular						
Capacity-BTU/HR (kW) (Includes Fan Motor)	38,000 (11.1)	56,300 (16.5)	58,800 (17.2)	98,100 (28.7)	121,500 (35.6)	126,900 (30)
Capacity-kW	10	15	15	25	30	30
No. of Stages	3	3	3	3	3	3
Humidifier Section						
Infrared Humidifier-Stainless Pan						
Capacity-lbs/hr (kg/h)	17.4 (7.9)	17.4 (7.9)	17.4 (7.9)	17.4 (7.9)	22.1 (10.0)	22.1 (10.0)
kW	6.4	6.4	6.4	6.4	9.6	9.6
Steam Generating Humidifier-Water conductivity between 200-500 micromhos is required for ideal operation						
Capacity-lbs/hr (kg/h)	11 (5.0)	11 (5.0)	11 (5.0)	22 (10.0)	22 (10.0)	22 (10.0)
-kW	3.6	3.6	3.6	7.2	7.2	7.2
Filter Section -Disposable Type (Nominal Sizes and Quantities)						
Downflow Models						
Nominal Size	24x24/18x24	24x24/18x24	24x24/18x24	24x24/18x24	24x24/18x24	24x24/18x24
Quantity	2/1	2/1	2/1	3/1	3/1	4/1
Upflow Models (Front & Rear Return)						
Nominal Size	20x16/20x25	20x16/20x25	20x16/20x25	24x24	24x24	24x24
Quantity	3/1	3/1	3/1	4	4	5
Modulating Three Way Econ-O-Valve (Maximum design water pressure 150 PSI. Higher pressure available as an option. Consult factory.)						
Valve Cv	28.9	28.9	28.9	46.2	46.2	46.2
Valve Size (Inches)	1-1/2	1-1/2	1-1/2	2	2	2
Safety Relief Valve - Lee Temp Only						
ASME Code Symbol	UV	UV	UV	UV	UV	UV
Setting-psi (kPa)	440 (3034)	440 (3034)	440 (3034)	440 (3034)	440 (3034)	440 (3034)
Drycooler (Standard Selection 95°F Amb.)*						
Model No.	D_-112	D_-174	D_-174	D_-260	D_-310	D_-466
No. of Fans	1	2	2	3	3	4
Approx. Weight lbs. (kg)	470 (213)	605 (274)	605 (274)	826 (375)	886 (402)	1250 (567)
Expansion Tank gallons (liters)	8.8 (33)	8.8 (33)	8.8 (33)	8.8 (33)	8.8 (33)	8.8 (33)
Pipe Connection Size (in.) FPT	2	2	2	2	2	2 1/2
*Specifications are those of Liebert manufactured systems. These may vary in local areas and verification with the Liebert representative is strongly recommended.						
Glycol Pumps-Standard Selection (1 per unit, standard) (4 Row Coil)						
Horsepower	1-1/2	1-1/2	2	3	3	5
Flow Rate-gpm (l/s)	28 (1.76)	32 (2.00)	38 (2.40)	54 (3.40)	67 (4.22)	78 (4.91)
Total Head Pressure-Ft. of water (kPa)	80 (239.2)	77 (230.2)	90 (269.1)	103 (308)	95 (284)	115 (343.8)
Suction Size-FPT*	1-1/4	1-1/4	1-1/4	1-1/2	1-1/2	1-1/2
Discharge Size-FPT*	3/4	3/4	3/4	1	1	1-1/4
*Sizes for primary vendor, will vary according to source of supply.						
Connection Sizes-Deluxe System/3						
Glycol Condenser-O.D. Copper	1-5/8	1-5/8	1-5/8	2-1/8	2-1/8	2-1/8
Infrared Humidifier-O.D. Copper	1/4	1/4	1/4	1/4	1/4	1/4
Condensate Drain-FPT	3/4	3/4	3/4	3/4	3/4	3/4
Pressure Drops at 40% Ethylene Glycol, 40°F (4.4°C) Avg. Temp.-Downflow Models (DE)						
Unit Internal Volume-gal. (liters)-max.	8.5 (32.0)	8.5 (32.0)	10.0 (38.0)	13.5 (51.0)	15.0 (57.0)	15.8 (60.0)
Unit Pressure Drop (Maximum)-4 row Ft. of water (kPa)-6 row	28.2 (84.3) 28.2 (84.3)	25.0 (74.7) 25.0 (74.7)	40.1 (119.9) 40.1 (119.9)	31.3 (93.6) 36.8 (110.0)	46.4 (138.7) 53.5 (160.0)	61.9 (185.0) ----
Drycooler Pressure Drop (Maximum) Ft. of water (kPa)	7.0 (20.9)	9.0 (26.9)	12.5 (37.3)	10.3 (30.7)	9.1 (27.2)	10.4 (31.0)
Pressure Drops at 40% Ethylene Glycol, 40°F (4.4°C) Avg. Temp.-Upflow Models (VE)						
Unit Internal Volume-gal. (liters)-max.	9.0 (34.0)	9.0 (34.0)	10.0 (38.0)	14.0 (53.0)	15.0 (57.0)	16.7 (63.2)
Unit Pressure Drop (Maximum) Ft. of water (kPa)	24.5 (73.3)	20.1 (60.1)	35.7 (106.7)	34.2 (102.3)	44.9 (134.3)	69.1 (206.2)
Drycooler Pressure Drop (Maximum) Ft. of water (kPa)	7.0 (20.9)	9.0 (26.9)	12.5 (37.3)	10.3 (30.7)	9.1 (27.2)	10.4 (31.0)
Weight-lbs. (kg)-Deluxe System/3	1615 (733)	1845 (837)	1860 (844)	2385 (1082)	2555 (1159)	2750 (1247)

DIMENSIONAL DATA

Table 3 Dimensional data—upflow models

Air Cooled	Water Cooled	Glycol Cooled/ GLYCOOL	# of Blowers	Std Motor HP*	Air Supply	Dimensional Data In. (mm)									
						H	J	K	L	M	N	P	R	S	
VH/VE 75A	VH/VE 86W	VH/VE 72G	1	1	Top Front	74 (1880)	70 (1778)	72 (1829)	72 (1829)	69-3/4 (1772)	72 (1829)	2-1/8 (54)	69-3/4 (1772)	20-1/4 (514)	
					Top Rear	74 (1880)	70 (1778)	72 (1829)	72 (1829)	69-3/4 (1772)	72 (1829)	2-1/8 (54)	69-3/4 (1772)	20-1/4 (514)	
VH/VE 114A	VH/VE 127W	VH/VE 110G	1	2	Top Front	74 (1880)	70 (1778)	72 (1829)	72 (1829)	69-3/4 (1772)	72 (1829)	2-1/8 (54)	69-3/4 (1772)	20-1/4 (514)	
					Top Rear	74 (1880)	70 (1778)	72 (1829)	72 (1829)	69-3/4 (1772)	72 (1829)	2-1/8 (54)	69-3/4 (1772)	20-1/4 (514)	
VH/VE 125A	VH/VE 138W	VH/VE 116G	1	3 or 5(VE)	Top Front	74 (1880)	70 (1778)	72 (1829)	72 (1829)	69-3/4 (1772)	72 (1829)	2-1/8 (54)	69-3/4 (1772)	20-1/4 (514)	
					Top Rear	74 (1880)	70 (1778)	72 (1829)	72 (1829)	69-3/4 (1772)	72 (1829)	2-1/8 (54)	69-3/4 (1772)	20-1/4 (514)	
VH/VE 199A	VH/VE 219W	VH/VE 192G	2	5	Top Front	99 (2515)	95 (2413)	76 (1930)	97 (2464)	94-3/4 (2407)	97 (2464)	2-1/8 (54)	94-3/4 (2407)	24-1/4 (616)	
					Top Rear	99 (2515)	95 (2413)	76 (1930)	97 (2464)	94-3/4 (2407)	97 (2464)	2-1/8 (54)	94-3/4 (2407)	24-1/4 (616)	
VH/VE 245A	VH/VE 267W	VH/VE 240G	2	7.5	Top Front	99 (2515)	95 (2413)	76 (1930)	97 (2464)	94-3/4 (2407)	97 (2464)	2-1/8 (54)	94-3/4 (2407)	24-1/4 (616)	
					Top Rear	99 (2515)	95 (2413)	76 (1930)	97 (2464)	94-3/4 (2407)	97 (2464)	2-1/8 (54)	94-3/4 (2407)	24-1/4 (616)	
VH 290A	VH 315W	VH 265G	2	10	Top Front	99 (2515)	95 (2413)	76 (1930)	97 (2464)	94-3/4 (2407)	97 (2464)	2-1/8 (54)	94-3/4 (2407)	24-1/4 (616)	
					Top Rear	99 (2515)	95 (2413)	76 (1930)	97 (2464)	94-3/4 (2407)	97 (2464)	2-1/8 (54)	94-3/4 (2407)	24-1/4 (616)	
VH/VE 380A	VH/VE 412W	VH/VE 363G	3	10	Top Front	122 (3099)	118 (2997)	76 (1930)	120 (3048)	113-1/2 (2883)	120 (3048)	4-1/4 (108)	117-1/2 (2985)	24-1/4 (616)	
					Top Rear	122 (3099)	118 (2997)	76 (1930)	120 (3048)	113-1/2 (2883)	120 (3048)	4-1/4 (108)	117-1/2 (2985)	24-1/4 (616)	

* For dimensions with optional HP motors consult Submittal Drawings or Installation Manual

Flange provided on blower outlet for supply air ducting. See Dimension F for flange height.

Minimum space required, in. (mm)

	Upflow
Front	24 (610)
Left	24 (610)
Right	24 (610)
Rear	0

This space is necessary to perform routine service such as:

1. Replacing 4" filters
2. Adjusting the fan speed, and
3. Cleaning the humidifier.

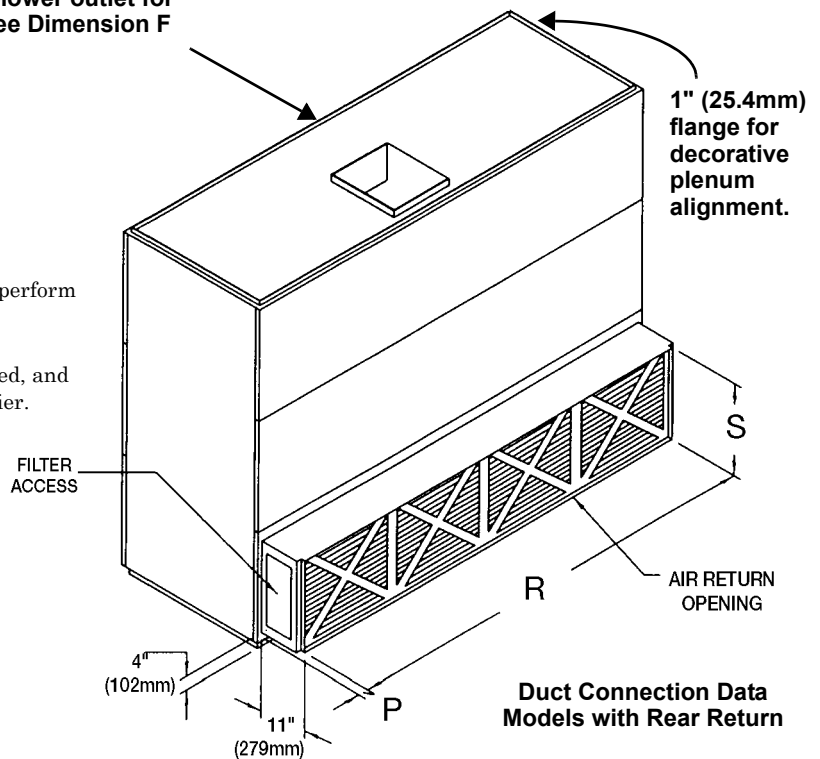

**Duct Connection Data
Models with Rear Return**

DPN000527 Rev0

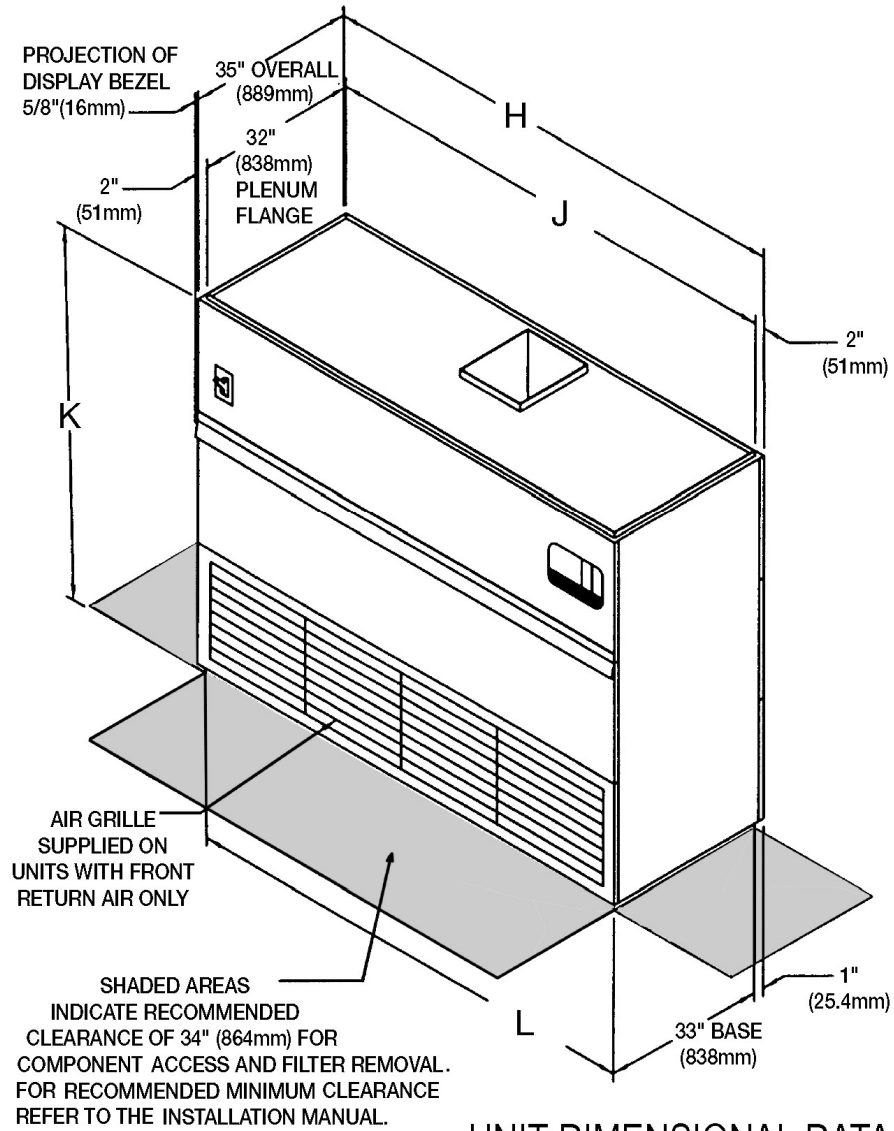

UNIT DIMENSIONAL DATA

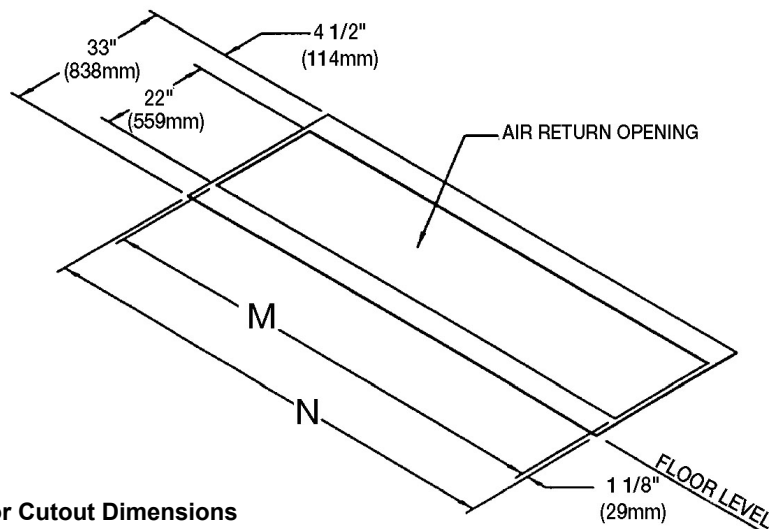

Floor Cutout Dimensions
Models with Bottom Return (Air Cooled Only)

DPN000527 Rev0

Table 4 Dimensional data—upflow models

Air Cooled	Water Cooled	Glycol Cooled/ GLYCOOL	# of Blowers	Std Motor HP*	Air Supply	Dimensional Data In. (mm)							
						A	B	C	D	E	F	G	K
VH/VE75A	VH/VE86W	VH/VE72G	1	1	Top Front	22-7/8 (581)	3-1/2 (89)	18-13/16 (478)	16-13/16 (411)	---	1-1/2 (38)	---	72 (1829)
					Top Rear	22-7/8 (581)	12-5/16 (313)	18-13/16 (478)	16-13/16 (411)	---	1-1/2 (38)	---	72 (1829)
VH/VE114A	VH/VE127W	VH/VE110G	1	2	Top Front	22-7/8 (581)	3-1/2 (89)	18-13/16 (478)	16-13/16 (411)	---	1-1/2 (38)	---	72 (1829)
					Top Rear	22-7/8 (581)	12-5/16 (313)	18-13/16 (478)	16-13/16 (411)	---	1-1/2 (38)	---	72 (1829)
VH/VE125A	VH/VE138W	VH/VE116G	1	3 or 5(VE)	Top Front	22-7/8 (581)	3-1/2 (89)	18-13/16 (478)	16-13/16 (411)	---	1-1/2 (38)	---	72 (1829)
					Top Rear	22-7/8 (581)	12-5/16 (313)	18-13/16 (478)	16-13/16 (411)	---	1-1/2 (38)	---	72 (1829)
VH/VE199A	VH/VE219W	VH/VE192G	2	5	Top Front	20-3/8 (518)	3-1/2 (89)	18-13/16 (478)	16-13/16 (411)	12-11/16 (322)	1-1/2 (38)	---	76 (1930)
					Top Rear	20-3/8 (518)	12-5/16 (313)	18-13/16 (478)	16-13/16 (411)	12-11/16 (322)	1-1/2 (38)	---	76 (1930)
VH/VE245A	VH/VE267W	VH/VE240G	2	7.5	Top Front	20-3/8 (518)	3-1/2 (89)	18-13/16 (478)	16-13/16 (411)	12-11/16 (322)	1-1/2 (38)	---	76 (1930)
					Top Rear	25-3/8 (645)	12-5/16 (313)	18-13/16 (478)	16-13/16 (411)	10 (254)	4-1/2 (114)	---	76 (1930)
VH290A	VH315W	VH265G	2	10	Top Front	20-3/8 (518)	3-1/2 (89)	18-13/16 (478)	16-13/16 (411)	12-11/16 (322)	1-1/2 (38)	---	76 (1930)
					Top Rear	25-3/8 (645)	12-5/16 (313)	18-13/16 (478)	16-13/16 (411)	10 (254)	4-1/2 (114)	---	76 (1930)
VH/VE380A	VH/VE412W	VH/VE363G	3	10	Top Front	22-7/8 (581)	3-1/2 (89)	18-13/16 (478)	16-13/16 (411)	10 (254)	1-1/2 (38)	18-5/8 (473)	76 (1930)
					Top Rear	22-7/8 (581)	12-5/16 (313)	18-13/16 (478)	16-13/16 (411)	10 (254)	4-1/2 (114)	18-5/8 (473)	76 (1930)

* For dimensions with optional HP motors consult Submittal Drawings or Installation Manual

Table 5 Upflow blower / motor requirements*

Air Cooled	Water Cooled	Glycol Cooled	CFM	External Static Pressure					
				0.50 Nom HP	1.00 Nom HP	1.50 Nom HP	2.00 Nom HP	2.50 Nom HP	3.00 Nom HP
VH75A	VH86W	VH72G	3350	1.0	1.5	2.0	2.0	3.0	5.0
			4650	2.0	3.0	3.0	5.0	5.0	5.0
VH114A	VH127W	VH110G	4650	2.0	3.0	3.0	5.0	5.0	5.0
			5650	3.0	5.0	5.0	7.5	7.5	7.5
VH125A	VH138W	VH116G	5650	3.0	5.0	5.0	7.5	7.5	7.5
			6400	5.0	5.0	7.5	7.5	10.0	10.0
VH199A	VH219W	VH192G	8400	5.0	5.0	7.5	7.5	7.5	15.0
			9400	5.0	7.5	7.5	10.0	10.0	15.0
VH245A	VH267W	VH240G	10200	7.5	7.5	10.0	10.0	15.0	15.0
			12000	10.0	10.0	15.0	15.0	15.0	20.0
VH290A	VH315W	VH265G	12000	10.0	10.0	15.0	15.0	15.0	20.0
VH380A	VH412W	VH363G	15200	10.0	15.0	15.0	20.0	20.0	20.0
Blower Size									
			15 x 15 Standard						
			15 x 11 Optional						
			12 x 9 Optional						

Vertical Front Return Unit (VH) with 4"-20% Filters and Ducted Blowers.

*For GLYCOOL units & units with nonstandard CFMs or other options that affect blower performance, contact your sales office or the factory.

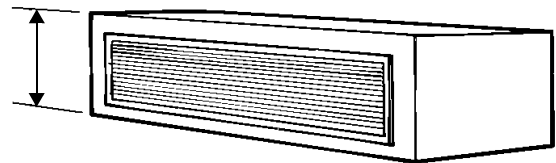
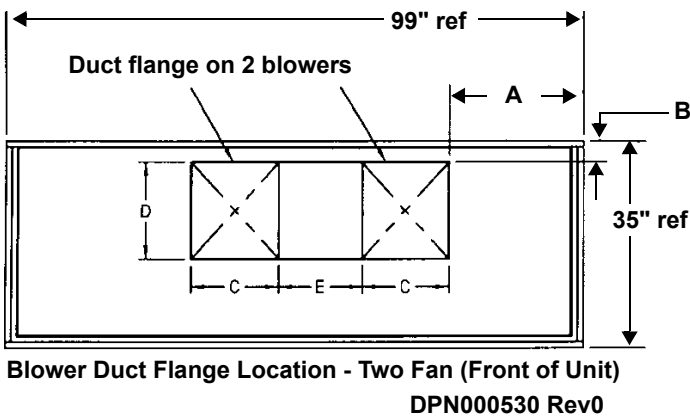
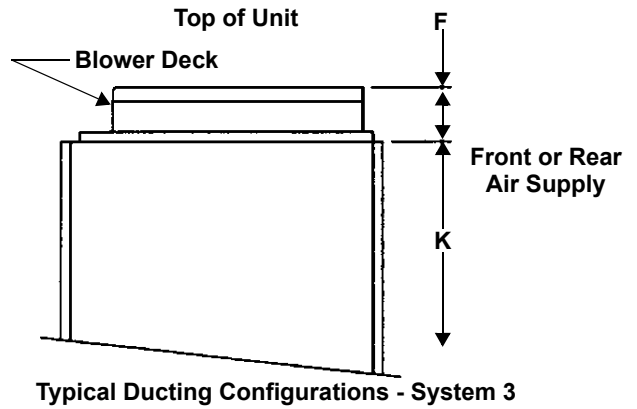
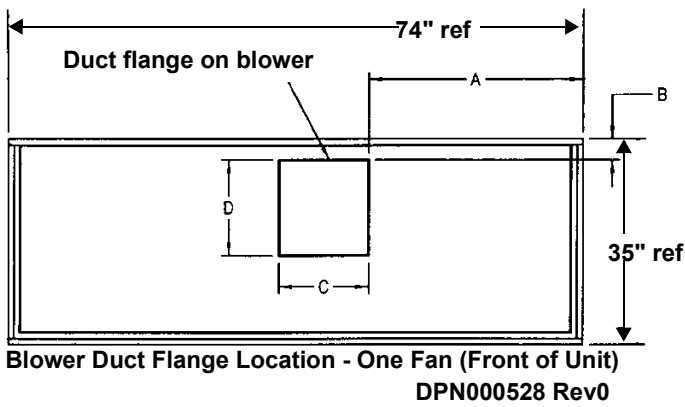

Decorative Plenum With or Without Grille for Upflow Units

Standard Plenum Heights

- 20" (510mm)
- 22-3/4" (578mm)
- 34-3/4" (883)

Plenums are the same width as unit
Depth is 1" (25.7mm) less than unit

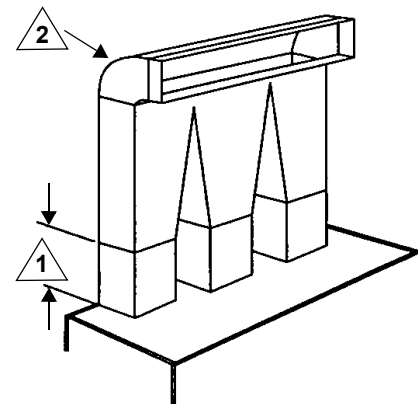
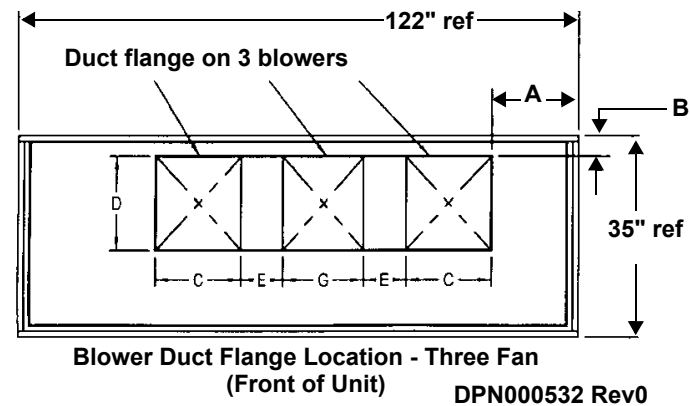

- 1 Straight section of duct off of unit to be 1.5 to 2.5 times the longest blower dimension.
- 2 Typical ducting shown, may run to either side.

DPN000533 Rev0

Table 6 Dimensional data—downflow models

Air Cooled	Water Cooled	Glycol or GLYCOOL Cooled	Dimensional Data In. (mm)									
			A	B	C	D	E	F	G	H	J	M
DH/DE75A	DH/DE86W	DH/DE72G	74 (1880)	70 (1178)	35 (889)	32 (813)	72 (1829)	33 (838)	13-1/4 (337)	61 (1549)	8 (203)	355/8 (905)
DH/DE114A	DH/DE127W	DH/DE110G	74 (1880)	70 (1178)	35 (889)	32 (813)	72 (1829)	33 (838)	13-1/4 (337)	61 (1549)	8 (203)	355/8 (905)
DH/DE125A	DH/DE138W	DH/DE116G	74 (1880)	70 (1178)	35 (889)	32 (813)	72 (1829)	33 (838)	13-1/4 (337)	61 (1549)	8 (203)	355/8 (905)
DH/DE199A	DH/DE219W	DH/DE192G	99 (2515)	95 (2413)	35 (889)	32 (813)	97 (2464)	33 (838)	15-1/4 (387)	783/4 (2000)	15-1/4 (387)	355/8 (905)
DH/DE245A	DH/DE267W	DH/DE240G	99 (2515)	95 (2413)	35 (889)	32 (813)	97 (2464)	33 (838)	15-1/4 (387)	783/4 (2000)	15-1/4 (387)	355/8 (905)
DH290A	DH315W	DH265G	99 (2515)	95 (2413)	35 (889)	32 (813)	97 (2464)	33 (838)	15-1/4 (387)	783/4 (2000)	15-1/4 (387)	355/8 (905)
DH/DE380A	DH/DE412W	DH/DE363G	122 (3099)	95 (2413)	35 (889)	32 (813)	120 (3048)	33 (838)	15-1/4 (387)	783/4 (2000)	15-1/4 (387)	355/8 (905)

Provide approximately 34" (864 mm) service clearance on the left, right and in front of the unit whenever possible.

Minimum space required, in. (mm)

	Downflow	
	Air	W/G/GLYCOOL
Front	24 (610)	24 (610)
Left	24 (610)	24 (610)
Right	0*	24 (610)
Rear	0	0

This space is necessary to perform routine service such as:

1. Replacing 4" filters
2. Adjusting the fan speed, and
3. Cleaning the humidifier.

* 24" (210mm) is required if unit has a return air plenum

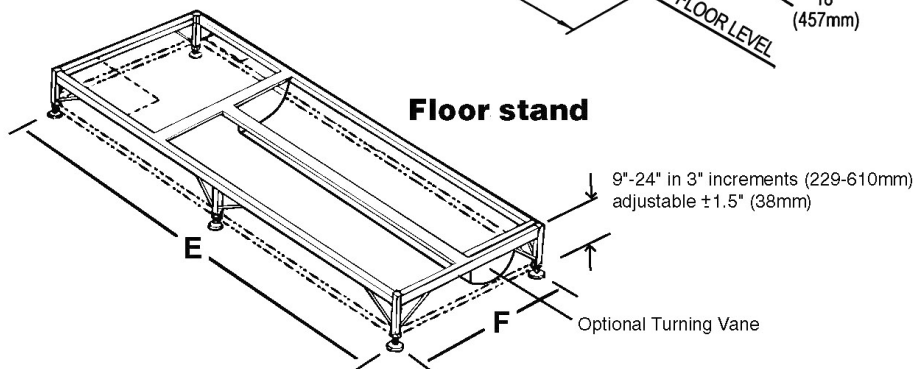
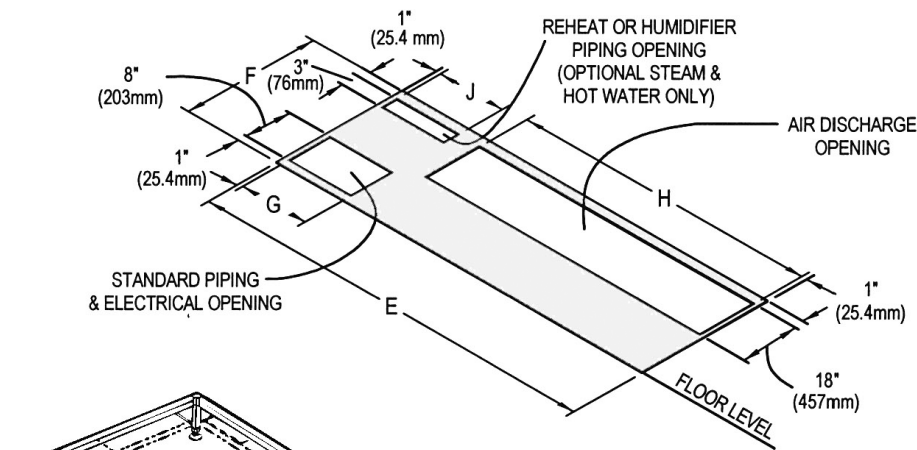
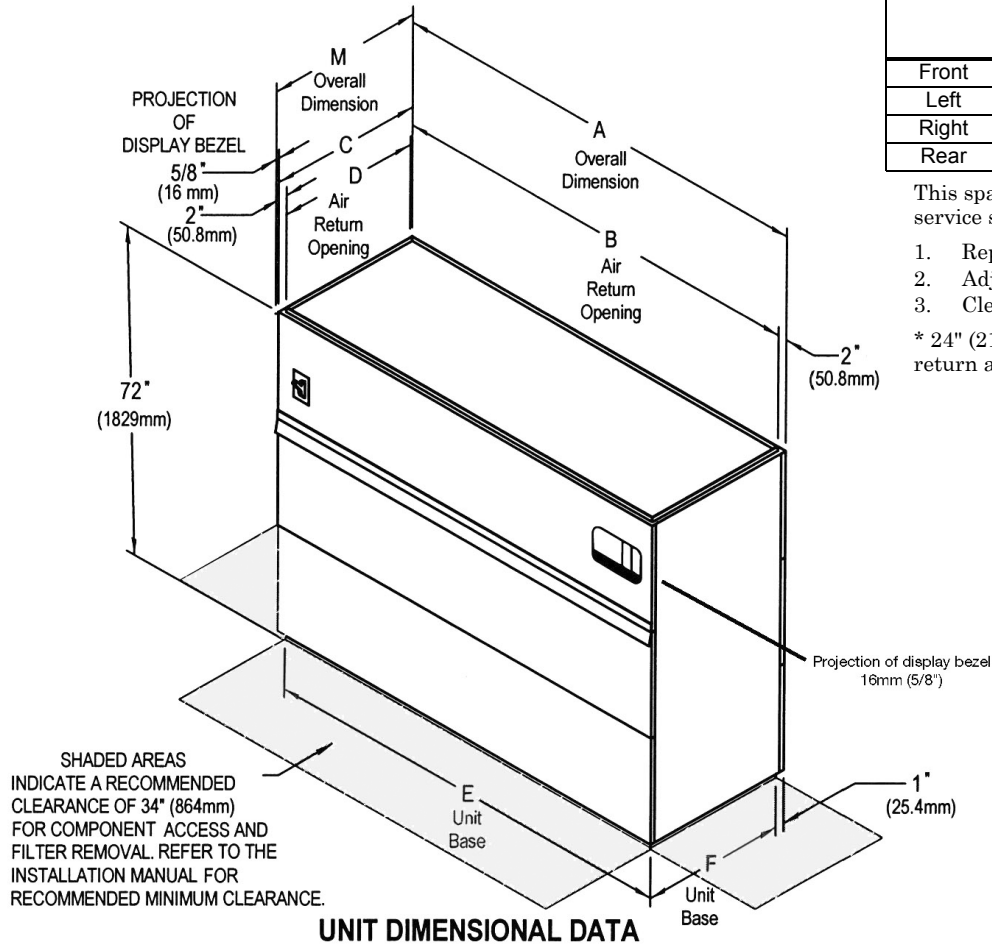

DPN000526 Rev0

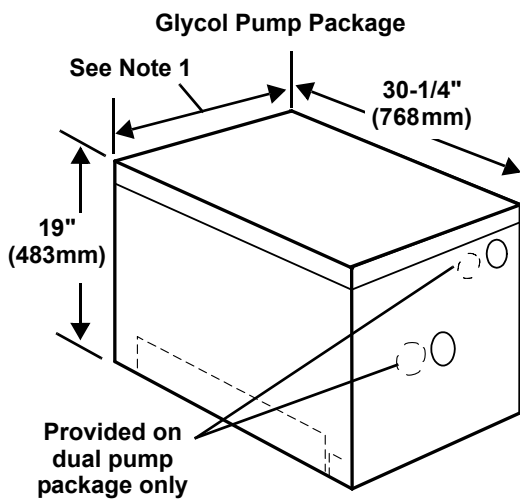
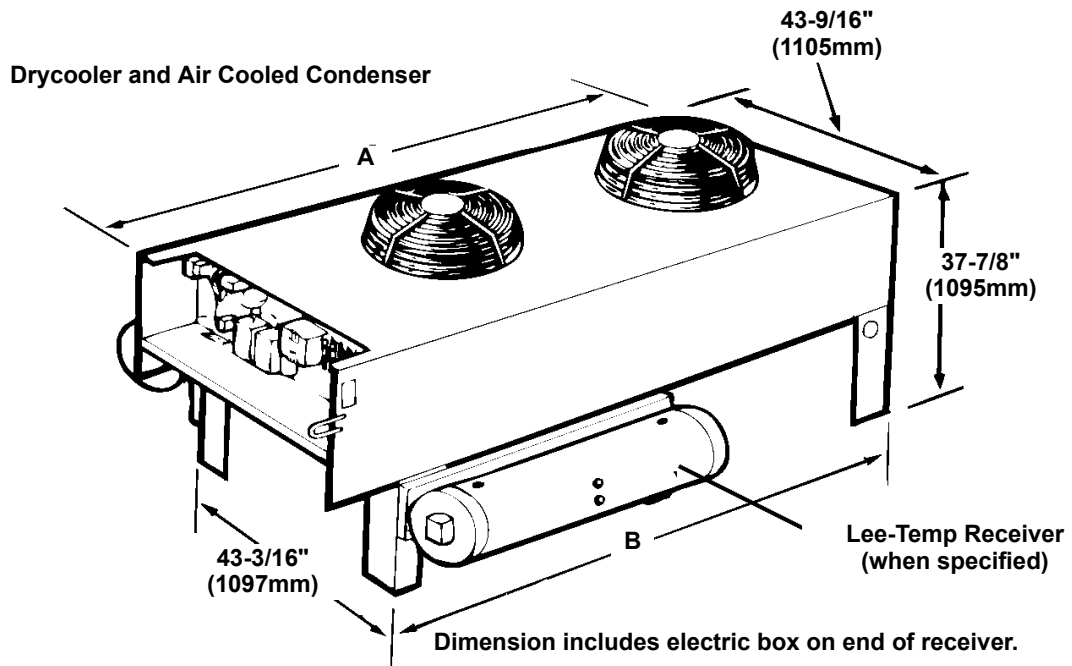

Notes

1. Single pump packages are 17-1/4" (438 mm) wide. Dual pump packages are 32-1/4" (819 mm) wide.

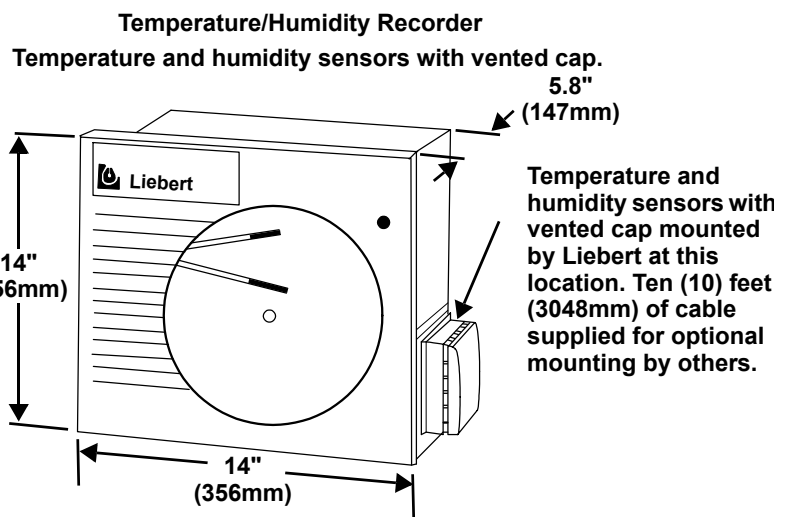

Table 7 Drycooler/condenser data

Model	A in. (mm)	B in. (mm)
1-Fan	51-7/16 (1308)	44 (1117.6)
2-Fan	91-7/16 (2324)	84 (2133.6)
3-Fan	131-7/16 (3340)	124 (3149.6)
4-Fan	171-1/2 (4356)	164 (4165.6)

ELECTRICAL SPECIFICATIONS

Downflow Models—Maximum Electrical Load Amperage

Table 8 Air, water, glycol cooled DH models; 3 phase, 60 cycle

Reheat Options		Electric				None, Steam or Hot Water				Electric				None, Steam or Hot Water			
Humidifier Options		Infrared or Steam Generating*				Infrared or Steam Generating*				Steam or None				Steam or None			
Models/ Motor hp	Volts	208	230	460	575	208	230	460	575	208	230	460	575	208	230	460	575
DH 1.0 hp	75A FLA	58.4	52.0	27.9	24.9	55.8	51.0	26.3	23.9	44.4	42.4	20.8	15.9	29.2	28.8	13.4	10.4
	86W WSA	73.0	65.0	34.9	31.1	59.0	54.2	27.7	25.0	54.5	52.1	25.5	19.5	32.4	32.0	14.9	11.5
	72G MFCB	80	60	35	35	70	60	30	25	60	50	25	20	40	40	20	15
DH 1.5 hp	75A FLA	60.1	53.6	28.7	25.6	57.5	52.6	27.1	24.6	46.1	44.0	21.6	16.6	30.9	30.4	14.2	11.1
	86W WSA	75.1	67.0	35.9	32.0	60.7	55.7	28.5	25.7	56.2	53.7	26.4	20.2	34.0	33.5	15.7	12.2
	72G MFCB	80	60	40	35	70	60	30	30	60	50	25	20	45	45	20	15
DH 1.5 hp	114A FLA	73.9	66.6	35.7	30.7	71.5	66.6	35.7	29.4	66.9	63.9	32.4	24.1	44.9	44.4	22.8	15.9
	127W WSA	92.4	83.1	44.0	38.4	76.4	71.5	38.2	31.1	82.2	78.6	39.9	29.6	49.8	49.3	25.3	17.6
	110G MFCB	90	90	45	40	90	90	45	35	90	80	45	30	60	60	35	20
DH 2.0 hp	114A FLA	75.7	68.2	36.5	31.3	73.3	68.2	36.5	30.0	68.7	65.5	33.2	24.7	46.7	46.0	23.6	16.5
	127W WSA	94.6	85.1	45.0	39.1	78.2	73.1	39.0	31.7	84.0	80.2	40.7	30.2	51.6	50.9	26.1	18.2
	110G MFCB	90	90	45	40	90	90	45	35	90	90	45	30	70	70	35	25
DH 2.0 hp	125A FLA	75.7	68.2	36.5	31.3	73.3	68.2	36.5	30.0	68.7	65.5	33.2	24.7	46.7	46.0	23.6	16.5
	138W WSA	94.6	85.1	45.0	39.1	78.2	73.1	39.0	31.7	84.0	80.2	40.7	30.2	51.6	50.9	26.1	18.2
	116G MFCB	90	90	45	40	90	90	45	35	90	90	45	30	70	70	35	25
DH 3.0 hp	125A FLA	78.8	71.0	37.9	32.5	76.4	71.0	37.9	31.2	71.8	68.3	34.6	25.9	49.8	48.8	25.0	17.7
	138W WSA	98.5	88.6	46.7	40.6	81.3	75.9	40.4	32.9	87.1	83.0	42.1	31.4	54.7	53.7	27.5	19.4
	116G MFCB	100	90	50	45	100	90	50	35	90	90	45	30	70	70	35	25
DH 3.0 hp	199A FLA	108.2	103.3	51.6	42.5	93.6	88.2	45.9	40.0	108.2	103.3	51.6	40.3	67.0	66.0	33.0	26.5
	219W WSA	133.2	126.7	63.3	53.1	100.7	95.2	49.4	42.8	132.6	126.7	63.3	49.4	74.1	73.1	36.5	29.3
	192G MFCB	125	125	60	50	125	110	60	50	125	125	60	50	100	100	50	40
DH 5.0 hp	199A FLA	114.3	108.9	54.4	44.7	99.7	93.8	48.7	42.2	114.3	108.9	54.4	42.5	73.1	71.6	35.8	28.7
	219W WSA	140.9	132.3	66.5	55.9	106.7	100.9	52.2	45.0	138.7	132.3	66.1	51.6	80.2	78.7	39.3	31.5
	192G MFCB	125	125	70	50	125	125	60	50	125	125	70	50	100	100	50	40
DH 5.0 hp	245A FLA	131.8	129.8	64.5	50.4	115.3	109.4	54.8	46.1	131.8	129.8	64.5	50.4	88.7	87.2	43.2	34.5
	267W WSA	160.6	158.4	78.7	61.5	124.3	118.4	59.2	49.7	160.6	158.4	78.7	61.5	97.7	96.2	47.6	38.0
	240G MFCB	175	150	80	60	150	150	70	60	175	150	80	60	125	125	60	50
DH 7.5 hp	245A FLA	139.3	136.6	67.9	53.3	122.8	116.2	58.2	49.0	139.3	136.6	67.9	53.3	96.2	94.0	46.6	37.4
	267W WSA	168.1	165.2	82.1	64.4	131.8	125.2	62.6	52.5	168.1	165.2	82.1	64.4	105.2	103.0	51.0	41.0
	240G MFCB	175	175	90	70	150	150	80	60	175	175	90	70	125	125	60	50
DH 7.5 hp	290A FLA	144.3	141.6	70.0	55.1	132.8	126.2	62.4	52.6	144.3	141.6	70.0	55.1	106.2	104.0	50.8	41.0
	315W WSA	174.3	171.5	84.7	66.6	143.1	136.4	67.4	56.6	174.3	171.5	84.7	66.6	116.4	114.2	55.8	45.0
	265G MFCB	175	175	90	70	175	175	80	70	175	175	90	70	150	150	70	60
DH 10.0 hp	380A FLA	171.6	164.4	78.7	63.6	171.6	164.4	76.8	63.6	167.0	163.7	78.7	61.6	145.0	142.2	65.2	52.0
	412W WSA	201.0	197.6	94.9	74.2	185.9	178.7	83.2	68.7	201.0	197.6	94.9	74.2	159.3	156.5	71.6	57.1
	363G MFCB	225	225	110	80	225	225	100	80	225	225	110	80	200	200	90	70

Standard unit with 0.5" external static pressure and standard cfm

1. FLA = Full Load Amps; WSA = Wire Sizing Amps; (Minimum supply circuit ampacity); MFCB = Maximum Fuse or Circuit Breaker Size
2. Amperage requirements are based on the rated max FLA. current of each component in the unit. The rated max FLA. current of the unit is not the sum total of all components, but is the total of the components which operate during maximum electrical load conditions.
3. The values in the chart are for power of the DH unit only. The only electrical connection between the outside heat rejection equipment and the DH unit is low voltage control wires. An electrical source is required for the air cooled condenser (**Table 14**) or glycol pump and drycooler (**Tables 16 and 17**).
4. For water cooled models with hot gas reheat, the above columns include amp values for one stage of electric reheat.

*When using steam generating humidifier on 6, 8, & 10 ton units, the electrical data is lower. Please consult Liebert for values.

**Units with Steam or Hot Water Reheat require optional fan motor (larger). Not available on 290A, 315W, 265G. Optional CFM ratings do not apply for units with steam or hot water reheat.

Table 9 Water cooled DH models with hot gas reheat

Reheat Options		Hot Gas/1 Electric				Hot Gas/1 Electric				
Humidifier Options		Infra-Red or Steam Generating*				Steam or None				
Models/Motor HP	Volts	208	230	460	575	208	230	460	575	
DH 1.0 hp	86W	FLA	55.8	51.0	26.3	23.9	32.6	31.3	15.2	11.7
		WSA	59.0	54.2	27.9	25.9	39.8	38.2	18.6	14.3
		MFCB	70	60	30	25	45	45	20	15
DH 1.5 hp	86W	FLA	57.5	52.6	27.1	24.6	34.3	32.9	16.0	12.4
		WSA	60.7	55.8	28.9	26.8	41.5	39.8	19.4	15.0
		MFCB	70	60	30	30	50	45	20	15
DH 1.5 hp	127W	FLA	71.5	66.6	35.7	29.4	49.4	47.4	24.1	17.7
		WSA	76.4	71.5	38.2	31.1	60.3	58.0	29.5	21.6
		MFCB	90	90	45	35	70	70	35	25
DH 2.0 hp	127W	FLA	73.3	68.2	36.5	30.0	51.2	49.0	24.9	18.3
		WSA	78.2	73.1	39.0	31.7	62.1	59.6	30.3	22.2
		MFCB	90	90	45	35	70	70	35	25
DH 2.0 hp	138W	FLA	73.3	68.2	36.5	30.0	51.2	49.0	24.9	18.3
		WSA	78.2	73.1	39.0	31.7	62.1	59.6	30.3	22.2
		MFCB	90	90	45	35	70	70	35	25
DH 3.0 hp	138W	FLA	76.4	71.0	37.9	31.2	54.3	51.8	26.3	19.5
		WSA	81.3	75.9	40.4	32.9	65.2	62.4	31.7	23.4
		MFCB	100	90	50	35	70	70	35	25
DH 3.0 hp	219W	FLA	93.6	88.2	45.9	40.0	78.9	75.6	37.8	29.7
		WSA	100.7	95.2	49.4	42.8	96.0	92.1	46.1	36.2
		MFCB	125	110	60	50	110	110	50	40
DH 5.0 hp	219W	FLA	99.7	93.8	48.7	42.2	85.0	81.2	40.6	31.9
		WSA	106.8	100.9	52.2	45.0	102.1	97.7	48.9	38.4
		MFCB	125	125	60	50	110	110	50	45
DH 5.0 hp	267W	FLA	115.3	109.4	54.8	46.1	98.4	96.6	48.0	37.7
		WSA	124.3	118.4	59.3	49.7	118.8	117.0	58.1	45.6
		MFCB	150	150	70	60	125	125	70	50
DH 7.5 hp	267W	FLA	122.8	116.2	58.2	49.0	105.9	103.4	51.4	40.6
		WSA	131.8	125.2	62.7	52.6	126.3	123.8	61.5	48.5
		MFCB	150	150	80	60	150	125	70	50
DH 7.5 hp	315W	FLA	132.8	126.2	62.4	52.6	110.9	108.4	53.5	42.4
		WSA	143.1	136.4	67.4	56.6	132.6	130.0	64.1	50.8
		MFCB	175	175	80	70	150	150	70	60

Standard unit with 0.5" external static pressure and standard cfm

1. FLA = Full Load Amps; WSA = Wire Sizing Amps (Minimum supply circuit ampacity); MFCB = Maximum Fuse or Circuit Breaker size
2. Amperage requirements are based on the rated max FLA. current of each component in the unit. The rated max FLA. current of the unit is not the sum total of all components, but is the total of the components which operate during maximum electrical load conditions.
3. The values in the chart are for power of the DH unit only. The only electrical connection between the outside heat rejection equipment and the DH unit is low voltage control wires. An electrical source is required for the air cooled condenser (**Table 14**) or glycol pump and drycooler (**Tables 16** and **17**).
4. For water cooled models with hot gas reheat, the above columns include amp values for one stage of electric reheat.

* When using steam generating humidifier on 6, 8, & 10 ton units, the electrical data is lower. Please consult Liebert for values.

**Units with Steam or Hot Water Reheat require optional fan motor (larger). Not available on 290A, 315W, 265G. Optional CFM ratings do not apply for units with steam or hot water reheat.

Table 10 Glycol cooled DH models with hot gas reheat

Reheat Options		Hot Gas					Hot Gas			
Humidifier Options		Infrared or Steam Generating*					Steam or None			
Models/Motor HP		Volts	208	230	460	575	208	230	460	575
DH 1.0 hp	72G	FLA	55.8	51.0	26.3	23.9	29.2	28.8	13.4	10.4
		WSA	59.0	54.2	27.8	25.0	32.4	32.0	14.9	11.5
		MFCB	70	60	30	25	40	40	20	15
DH 1.5 hp	72G	FLA	57.5	52.6	27.1	24.6	30.9	30.4	14.2	11.1
		WSA	60.7	55.8	28.6	25.7	34.1	33.6	15.7	12.2
		MFCB	70	60	30	30	45	45	20	15
DH 1.5 hp	110G	FLA	71.5	66.6	35.7	29.4	44.9	44.4	22.8	15.9
		WSA	76.4	71.5	38.2	31.1	49.8	49.3	25.3	17.6
		MFCB	90	90	45	35	60	60	35	20
DH 2.0 hp	110G	FLA	73.3	68.2	36.5	30.0	46.7	46.0	23.6	16.5
		WSA	78.2	73.1	39.0	31.7	51.6	50.9	26.1	18.2
		MFCB	90	90	45	35	70	70	35	25
DH 2.0 hp	116G	FLA	73.3	68.2	36.5	30.0	46.7	46.0	23.6	16.5
		WSA	78.2	73.1	39.0	31.7	51.6	50.9	26.1	18.2
		MFCB	90	90	45	35	70	70	35	25
DH 3.0 hp	116G	FLA	76.4	71.0	37.9	31.2	49.8	48.8	25.0	17.7
		WSA	81.3	75.9	40.4	32.9	54.7	53.7	27.5	19.4
		MFCB	100	90	50	35	70	70	35	25
DH 3.0 hp	192G	FLA	93.6	88.2	45.9	40.0	67.0	66.0	33.0	26.5
		WSA	100.7	95.3	49.4	42.8	74.1	73.1	36.5	29.3
		MFCB	125	110	60	50	100	100	50	40
DH 5.0 hp	192G	FLA	99.7	93.8	48.7	42.2	73.1	71.6	35.8	28.7
		WSA	106.8	100.9	52.2	45.0	80.2	78.7	39.3	31.5
		MFCB	125	125	60	50	100	100	50	40
DH 5.0 hp	240G	FLA	115.3	109.4	54.8	46.1	88.7	87.2	43.2	34.5
		WSA	124.3	118.4	59.3	49.7	97.7	96.2	47.7	38.1
		MFCB	150	150	70	60	125	125	60	50
DH 7.5 hp	240G	FLA	122.8	116.2	58.2	49.0	96.2	94.0	46.6	37.4
		WSA	131.8	125.2	62.7	52.6	105.2	103.0	51.1	41.0
		MFCB	150	150	80	60	125	125	60	50
DH 7.5 hp	265G	FLA	132.8	126.2	62.4	52.6	106.2	104.0	50.8	41.0
		WSA	143.1	136.5	67.4	56.6	116.5	114.3	55.8	45.0
		MFCB	175	175	80	70	150	150	70	60

Standard unit with 0.5" external static pressure and standard cfm

1. FLA = Full Load Amps; WSA = Wire Sizing Amps (Minimum supply circuit ampacity); MFCB = Maximum Fuse or Circuit Breaker Size
2. Amperage requirements are based on the rated max FLA. current of each component in the unit. The rated max FLA. current of the unit is not the sum total of all components, but is the total of the components which operate during maximum electrical load conditions.
3. The values in the chart are for power of the DH unit only. The only electrical connection between the outside heat rejection equipment and the DH unit is low voltage control wires. An electrical source is required for the air cooled condenser (Table 14) or glycol pump and drycooler (Tables 16 and 17).
4. Optional CFM ratings do not apply for units with steam or hot water reheat.

*When using steam generating humidifier on 6, 8, & 10 ton units, the electrical data is lower. Please consult Liebert for values.

Upflow Models—Maximum Electrical Load Amperage

Table 11 Air, water, glycol cooled VH models; 3 phase, 60 cycle

Reheat Options		Electric					None, Steam or Hot Water				Electric				None, Steam or Hot Water			
Humidifier Options		Infrared or Steam Generating*					Infrared or Steam Generating*				Steam or None				Steam or None			
Models / Motor HP	Volts	208	230	460	575	208	230	460	575	208	230	460	575	208	230	460	575	
VH 1.0 hp	75A FLA	58.4	52.0	27.9	24.9	55.8	51.0	26.3	23.9	44.4	42.4	20.8	15.9	29.2	28.8	13.4	10.4	
	86W WSA	73.0	65.0	34.9	31.1	59.0	54.2	27.7	25.0	54.5	52.1	25.5	19.5	32.4	32.0	14.9	11.5	
	72G MFCB	80	60	35	35	70	60	30	25	60	50	25	20	40	40	20	15	
VH 1.5 hp	75A FLA	60.1	53.6	28.7	25.6	57.5	52.6	27.1	24.6	46.1	44.0	21.6	16.6	30.9	30.4	14.2	11.1	
	86W WSA	75.1	67.0	35.9	32.0	60.7	55.7	28.5	25.7	56.2	53.7	26.4	20.2	34.0	33.5	15.7	12.2	
	72G MFCB	80	60	40	35	70	60	30	30	60	50	25	20	45	45	20	15	
VH 2.0 hp	75A FLA	61.9	55.2	29.5	26.2	59.3	54.2	27.9	25.2	47.9	45.6	22.4	17.2	32.7	32.0	15.0	11.7	
	86W WSA	77.4	69.0	36.9	32.7	62.5	57.4	29.4	26.3	58.0	55.3	27.1	20.8	35.9	35.2	16.5	12.8	
	72G MFCB	80	60	40	35	70	60	35	30	60	60	25	20	45	45	20	15	
VH 3.0 hp	75A FLA	65.0	58.0	30.9	27.4	62.4	57.0	29.3	26.4	51.0	48.4	23.8	18.4	35.8	34.8	16.4	12.9	
	86W WSA	81.3	72.5	38.6	34.2	65.6	60.2	30.7	27.5	61.1	58.1	28.5	22.0	39.0	38.0	17.9	14.0	
	72G MFCB	90	70	40	35	70	70	35	30	60	60	30	20	50	50	20	15	
VH 5.0 hp	75A FLA	71.1	63.6	33.7	29.6	68.5	62.6	32.1	28.6	57.1	54.0	26.6	20.6	41.9	40.4	19.2	15.1	
	86W WSA	88.9	79.5	42.1	37.0	72.7	66.4	34.0	30.1	68.2	64.3	31.8	24.6	46.1	44.2	21.1	16.6	
	72G MFCB	90	80	40	35	80	80	40	35	70	70	35	25	60	50	25	20	
VH 1.5 hp	114A FLA	73.9	66.6	35.7	30.7	71.5	66.6	35.7	29.4	66.9	63.9	32.4	24.1	44.9	44.4	22.8	15.9	
	127W WSA	92.4	83.1	44.0	38.4	76.4	71.5	38.2	31.1	82.2	78.6	39.9	29.6	49.8	49.3	25.3	17.6	
	110G MFCB	90	90	45	40	90	90	45	35	90	80	45	30	60	60	35	20	
VH 2.0 hp	114A FLA	75.7	68.2	36.5	31.3	73.3	68.2	36.5	30.0	68.7	65.5	33.2	24.7	46.7	46.0	23.6	16.5	
	127W WSA	94.6	85.1	45.0	39.1	78.2	73.1	39.0	31.7	84.0	80.2	40.7	30.2	51.6	50.9	26.1	18.2	
	110G MFCB	90	90	45	40	90	90	45	35	90	90	45	30	70	70	35	25	
VH 3.0 hp	114A FLA	78.8	71.0	37.9	32.5	76.4	71.0	37.9	31.2	71.8	68.3	34.6	25.9	49.8	48.8	25.0	17.7	
	127W WSA	98.5	88.6	46.7	40.6	81.3	75.9	40.4	32.9	87.1	83.0	42.1	31.4	54.7	53.7	27.5	19.4	
	110G MFCB	100	90	50	45	100	90	50	35	90	90	45	30	70	70	35	25	
VH 5.0 hp	114A FLA	84.9	76.6	40.7	34.7	82.5	76.6	40.7	33.4	77.9	73.9	37.4	28.1	55.9	54.4	27.8	19.9	
	127W WSA	106.1	95.6	50.2	43.4	87.4	81.5	43.2	35.1	93.2	88.6	44.9	33.6	60.8	59.3	30.3	21.6	
	110G MFCB	100	100	50	45	100	100	50	40	100	90	50	35	80	70	40	25	
VH 7.5 hp	114A FLA	92.4	83.4	44.1	37.6	90.0	83.4	44.1	36.3	85.4	80.7	40.8	31.0	63.4	61.2	31.2	22.8	
	127W WSA	115.5	104.1	54.5	47.0	96.1	88.9	46.8	38.5	101.8	96.0	48.5	37.0	69.5	66.7	34.0	25.0	
	110G MFCB	110	110	50	45	110	110	50	45	110	100	50	40	90	80	40	30	
VH 2.0 hp	125A FLA	75.7	68.2	36.5	31.3	73.3	68.2	36.5	30.0	68.7	65.5	33.2	24.7	46.7	46.0	23.6	16.5	
	138W WSA	94.6	85.1	45.0	39.1	78.2	73.1	39.0	31.7	84.0	80.2	40.7	30.2	51.6	50.9	26.1	18.2	
	116G MFCB	90	90	45	40	90	90	45	35	90	90	45	30	70	70	35	25	
VH 3.0 hp	125A FLA	78.8	71.0	37.9	32.5	76.4	71.0	37.9	31.2	71.8	68.3	34.6	25.9	49.8	48.8	25.0	17.7	
	138W WSA	98.5	88.6	46.7	40.6	81.3	75.9	40.4	32.9	87.1	83.0	42.1	31.4	54.7	53.7	27.5	19.4	
	116G MFCB	100	90	50	45	100	90	50	35	90	90	45	30	70	70	35	25	
VH 5.0 hp	125A FLA	84.9	76.6	40.7	34.7	82.5	76.6	40.7	33.4	77.9	73.9	37.4	28.1	55.9	54.4	27.8	19.9	
	138W WSA	106.1	95.6	50.2	43.4	87.4	81.5	43.2	35.1	93.2	88.6	44.9	33.6	60.8	59.3	30.3	21.6	
	116G MFCB	100	100	50	45	100	100	50	40	100	90	50	35	80	70	40	25	
VH 7.5 hp	125A FLA	92.4	83.4	44.1	37.6	90.0	83.4	44.1	36.3	85.4	80.7	40.8	31.0	63.4	61.2	31.2	22.8	
	138W WSA	115.5	104.1	54.5	47.0	96.1	88.9	46.8	38.5	101.8	96.0	48.5	37.0	69.5	66.7	34.0	25.0	
	116G MFCB	110	110	50	45	110	110	50	45	110	100	50	40	90	80	40	30	
VH 10.0 hp	125A FLA	99.0	89.4	47.1	39.6	96.6	89.4	47.1	38.3	92.0	86.7	43.8	33.0	70.0	67.2	34.2	24.8	
	138W WSA	123.7	111.6	58.2	49.5	104.3	96.4	50.6	41.0	110.1	103.5	52.2	39.5	77.7	74.2	37.7	27.5	
	116G MFCB	125	110	60	50	125	110	60	50	125	110	60	45	100	100	50	35	

*When using steam generating humidifier on 6, 8, & 10 ton units, the electrical data is lower. Please consult Liebert for values.

Standard unit with 0.5" external static pressure and standard CFM

Table 11 Air, water, glycol cooled VH models; 3 phase, 60 cycle (continued)

Reheat Options		Electric				None, Steam or Hot Water				Electric				None, Steam or Hot Water			
Humidifier Options		Infrared or Steam Generating*				Infrared or Steam Generating*				Steam or None				Steam or None			
Models / Motor HP	Volts	208	230	460	575	208	230	460	575	208	230	460	575	208	230	460	575
VH 3.0 hp	199A FLA	108.2	103.3	51.6	42.5	93.6	88.2	45.9	40.0	108.2	103.3	51.6	40.3	67.0	66.0	33.0	26.5
	219W WSA	133.2	126.7	63.3	53.1	100.7	95.2	49.4	42.8	132.6	126.7	63.3	49.4	74.1	73.1	36.5	29.3
	192G MFCB	125	125	60	50	125	110	60	50	125	125	60	50	100	100	50	40
VH 5.0 hp	199A FLA	114.3	108.9	54.4	44.7	99.7	93.8	48.7	42.2	114.3	108.9	54.4	42.5	73.1	71.6	35.8	28.7
	219W WSA	140.9	132.3	66.5	55.9	106.7	100.9	52.2	45.0	138.7	132.3	66.1	51.6	80.2	78.7	39.3	31.5
	192G MFCB	125	125	70	50	125	125	60	50	125	125	70	50	100	100	50	40
VH 7.5 hp	199A FLA	121.8	115.7	57.8	47.6	107.2	100.6	52.1	45.1	121.8	115.7	57.8	45.4	80.6	78.4	39.2	31.6
	219W WSA	150.2	139.1	70.7	59.5	114.2	107.7	55.6	47.9	146.2	139.1	69.5	54.5	87.7	85.5	42.7	34.4
	192G MFCB	150	150	70	50	125	125	60	50	150	150	70	50	110	110	50	45
VH 10.0 hp	199A FLA	128.4	121.7	60.8	49.6	113.8	106.6	55.1	47.1	128.4	121.7	60.8	47.4	87.2	84.4	42.2	33.6
	219W WSA	158.5	145.1	74.5	62.0	121.5	113.7	58.6	49.9	153.4	145.1	72.5	56.5	94.9	91.5	45.7	36.4
	192G MFCB	150	150	70	60	150	125	70	60	150	150	70	60	125	110	50	45
VH 15.0 hp	199A FLA	143.8	135.7	67.8	55.6	129.2	120.6	62.1	53.1	143.8	135.7	67.8	53.4	102.6	98.4	49.2	39.6
	219W WSA	177.7	162.6	83.2	69.5	140.7	131.1	67.3	57.3	172.7	162.6	81.2	63.9	114.2	108.9	54.5	43.8
	192G MFCB	200	175	90	70	175	150	80	70	200	175	90	70	150	150	70	60
VH 5.0 hp	245A FLA	131.8	129.8	64.5	50.4	115.3	109.4	54.8	46.1	131.8	129.8	64.5	50.4	88.7	87.2	43.2	34.5
	267W WSA	160.6	158.4	78.7	61.5	124.3	118.4	59.2	49.7	160.6	158.4	78.7	61.5	97.7	96.2	47.6	38.0
	240G MFCB	175	150	80	60	150	150	70	60	175	150	80	60	125	125	60	50
VH 7.5 hp	245A FLA	139.3	136.6	67.9	53.3	122.8	116.2	58.2	49.0	139.3	136.6	67.9	53.3	96.2	94.0	46.6	37.4
	267W WSA	168.1	165.2	82.1	64.4	131.8	125.2	62.6	52.5	168.1	165.2	82.1	64.4	105.2	103.0	51.0	41.0
	240G MFCB	175	175	90	70	150	150	80	60	175	175	90	70	125	125	60	50
VH 10.0 hp	245A FLA	145.9	142.6	70.9	55.3	129.4	122.2	61.2	51.0	145.9	142.6	70.9	55.3	102.8	100.0	49.6	39.4
	267W WSA	174.7	171.2	85.1	66.4	138.4	131.2	65.7	54.5	174.7	171.2	85.1	66.4	111.8	109.0	54.0	43.0
	240G MFCB	175	175	90	70	150	150	80	60	175	175	90	70	125	125	70	50
VH 15.0 hp	245A FLA	161.3	156.6	77.9	61.3	144.8	136.2	68.2	57.0	161.3	156.6	77.9	61.3	118.2	114.0	56.6	45.4
	267W WSA	192.6	186.7	92.9	73.4	156.4	146.7	73.4	61.2	192.6	186.7	92.9	73.1	129.7	124.5	61.8	49.7
	240G MFCB	200	200	100	80	200	175	90	70	200	200	100	80	175	150	80	60
VH 20.0 hp	245A FLA	174.5	168.6	83.9	66.3	158.0	148.2	74.2	62.0	174.5	168.6	83.9	66.3	131.4	126.0	62.6	50.4
	267W WSA	209.1	201.7	100.4	79.6	172.9	161.7	80.9	67.5	209.1	201.7	100.4	79.3	146.2	139.5	69.3	55.9
	240G MFCB	225	225	110	90	225	200	100	80	225	225	110	90	200	175	90	70
VH 5.0 hp	290A FLA	136.8	134.8	66.6	52.2	125.3	119.4	59.0	49.7	136.8	134.8	66.6	52.2	98.7	97.2	47.4	38.1
	315W WSA	166.8	164.7	81.3	63.7	135.6	129.6	64.0	53.7	166.8	164.7	81.3	63.7	108.9	107.4	52.4	42.1
	265G MFCB	175	175	90	70	175	150	80	60	175	175	90	70	125	125	70	50
VH 7.5 hp	290A FLA	144.3	141.6	70.0	55.1	132.8	126.2	62.4	52.6	144.3	141.6	70.0	55.1	106.2	104.0	50.8	41.0
	315W WSA	174.3	171.5	84.7	66.6	143.1	136.4	67.4	56.6	174.3	171.5	84.7	66.6	116.4	114.2	55.8	45.0
	265G MFCB	175	175	90	70	175	175	80	70	175	175	90	70	150	150	70	60
VH 10.0 hp	290A FLA	150.9	147.6	73.0	57.1	139.4	132.2	65.4	54.6	150.9	147.6	73.0	57.1	112.8	110.0	53.8	43.0
	315W WSA	180.9	177.5	87.7	68.6	149.6	142.4	70.4	58.6	180.9	177.5	87.7	68.6	123.1	120.2	58.8	47.0
	265G MFCB	200	175	90	70	175	175	90	70	200	175	90	70	150	150	70	60
VH 15.0 hp	290A FLA	166.3	161.6	80.0	63.1	154.8	146.2	72.4	60.6	166.3	161.6	80.0	63.1	128.2	124.0	60.8	49.0
	315W WSA	197.6	191.7	95.0	74.9	166.4	156.7	77.7	64.8	197.6	191.7	95.0	74.9	139.7	134.5	66.1	53.2
	265G MFCB	200	200	100	80	200	175	90	80	200	200	100	80	175	175	80	70
VH 20.0 hp	290A FLA	179.5	173.6	86.0	68.1	168.0	158.2	78.4	65.6	179.5	173.6	86.0	68.1	141.5	136.0	66.8	54.0
	315W WSA	214.1	206.7	102.5	81.1	182.9	171.7	85.2	71.1	214.1	206.7	102.5	81.1	156.3	149.5	73.6	59.5
	265G MFCB	250	225	110	90	225	225	110	90	250	225	110	90	200	200	100	80
VH 10.0 hp	380A FLA	171.6	164.4	78.7	63.6	171.6	164.4	76.8	63.6	167.0	163.7	78.7	61.6	145.0	142.2	65.2	52.0
	412W WSA	201.0	197.6	94.9	74.2	185.9	178.7	83.2	68.7	201.0	197.6	94.9	74.2	159.3	156.5	71.6	57.1
	363G MFCB	225	225	110	80	225	225	100	80	225	225	110	80	200	200	90	70
VH 15.0 hp	380A FLA	187.0	178.4	85.7	69.6	187.0	178.4	83.8	69.6	182.4	177.7	85.7	67.6	160.4	156.2	72.2	58.0
	412W WSA	216.4	211.6	101.9	80.2	201.3	192.7	90.2	74.7	216.4	211.6	101.9	80.2	174.7	170.5	78.6	63.1
	363G MFCB	250	225	110	90	250	225	110	90	250	225	110	90	225	225	100	80
VH 20.0 hp	380A FLA	200.2	190.4	91.7	74.6	200.2	190.4	89.8	74.6	195.6	189.7	91.7	72.6	173.6	168.2	78.2	63.0
	412W WSA	230.2	223.6	108.2	85.6	215.1	204.7	96.6	80.1	230.2	223.6	108.2	85.6	188.4	182.5	84.9	68.5
	363G MFCB	250	250	125	100	250	250	110	100	250	250	125	100	225	225	110	90

*When using steam generating humidifier on 6, 8, & 10 ton units, the electrical data is lower. Please consult Liebert for values.

Standard unit with 0.5" external static pressure and standard CFM

1. FLA = Full Load Amps; WSA = Wire Sizing Amps (minimum supply circuit ampacity); MFCB = Maximum Fuse or Circuit Breaker Size
2. Amperage requirements are based on the rated max F.L.A. current of each component in the unit. The rated max F.L.A. current of the unit is not the sum total of all components, but is the total of the components which operate during maximum electrical load conditions.
3. The values in the chart are for power of the VH unit only. The only electrical connection between the outside heat rejection equipment and the VH unit is low voltage control wires. An electrical source is required for the air cooled condenser (Table 14) or glycol pump and drycooler (Tables 16 and 17).

* When using steam generating humidifier on 6, 8, & 10 ton units, the electrical data is lower. Please consult Liebert for values.

Table 12 GLYCOOL, dual cool VE models; 3 phase, 60 cycle

Reheat Options			Electric				None, Steam or Hot Water				Electric				None, Steam or Hot Water			
Humidifier Options			Infrared or Steam Generating*				Infrared or Steam Generating*				None				None			
Models / Motor HP	Volts		208	230	460	575	208	230	460	575	208	230	460	575	208	230	460	575
VE 1.0 hp	75A	FLA	58.4	52.0	27.9	24.9	55.8	51.0	26.3	23.9	44.4	42.4	20.8	15.9	29.2	28.8	13.4	10.4
	86W	WSA	73.0	65.0	34.9	31.1	59.0	54.2	27.7	25.0	54.5	52.1	25.5	19.5	32.4	32.0	14.9	11.5
	72G	MFCB	80	60	35	35	70	60	30	25	60	50	25	20	40	40	20	15
VE 1.5 hp	75A	FLA	60.1	53.6	28.7	25.6	57.5	52.6	27.1	24.6	46.1	44.0	21.6	16.6	30.9	30.4	14.2	11.1
	86W	WSA	75.1	67.0	35.9	32.0	60.7	55.7	28.5	25.7	56.2	53.7	26.4	20.2	34.0	33.5	15.7	12.2
	72G	MFCB	80	60	40	35	70	60	30	30	60	50	25	20	45	45	20	15
VE 2.0 hp	75A	FLA	61.9	55.2	29.5	26.2	59.3	54.2	27.9	25.2	47.9	45.6	22.4	17.2	32.7	32.0	15.0	11.7
	86W	WSA	77.4	69.0	36.9	32.7	62.5	57.4	29.4	26.3	58.0	55.3	27.1	20.8	35.9	35.2	16.5	12.8
	72G	MFCB	80	60	40	35	70	60	35	30	60	60	25	20	45	45	20	15
VE 3.0 hp	75A	FLA	65.0	58.0	30.9	27.4	62.4	57.0	29.3	26.4	51.0	48.4	23.8	18.4	35.8	34.8	16.4	12.9
	86W	WSA	81.3	72.5	38.6	34.2	65.6	60.2	30.7	27.5	61.1	58.1	28.5	22.0	39.0	38.0	17.9	14.0
	72G	MFCB	90	70	40	35	70	70	35	30	60	60	30	20	50	50	20	15
VE 5.0 hp	75A	FLA	71.1	63.6	33.7	29.6	68.5	62.6	32.1	28.6	57.1	54.0	26.6	20.6	41.9	40.4	19.2	15.1
	86W	WSA	88.9	79.5	42.1	37.0	72.7	66.4	34.0	30.1	68.2	64.3	31.8	24.6	46.1	44.2	21.1	16.6
	72G	MFCB	90	80	40	35	80	80	40	35	70	70	35	25	60	50	25	20
VE 2.0 hp	114A	FLA	75.7	68.2	36.5	31.3	73.3	68.2	36.5	30.0	68.7	65.5	33.2	24.7	46.7	46.0	23.6	16.5
	127W	WSA	94.6	85.1	45.0	39.1	78.2	73.1	39.0	31.7	84.0	80.2	40.7	30.2	51.6	50.9	26.1	18.2
	110G	MFCB	90	90	45	40	90	90	45	35	90	90	45	30	70	70	35	25
VE 3.0 hp	114A	FLA	78.8	71.0	37.9	32.5	76.4	71.0	37.9	31.2	71.8	68.3	34.6	25.9	49.8	48.8	25.0	17.7
	127W	WSA	98.5	88.6	46.7	40.6	81.3	75.9	40.4	32.9	87.1	83.0	42.1	31.4	54.7	53.7	27.5	19.4
	110G	MFCB	100	90	50	45	100	90	50	35	90	90	45	30	70	70	35	25
VE 5.0 hp	114A	FLA	84.9	76.6	40.7	34.7	82.5	76.6	40.7	33.4	77.9	73.9	37.4	28.1	55.9	54.4	27.8	19.9
	127W	WSA	106.1	95.6	50.2	43.4	87.4	81.5	43.2	35.1	93.2	88.6	44.9	33.6	60.8	59.3	30.3	21.6
	110G	MFCB	100	100	50	45	100	100	50	40	100	90	50	35	80	70	40	25
VE 7.5 hp	114A	FLA	92.4	83.4	44.1	37.6	90.0	83.4	44.1	36.3	85.4	80.7	40.8	31.0	63.4	61.2	31.2	22.8
	127W	WSA	115.5	104.1	54.5	47.0	96.1	88.9	46.8	38.5	101.8	96.0	48.5	37.0	69.5	66.7	34.0	25.0
	110G	MFCB	110	110	50	45	110	110	50	45	110	100	50	40	90	80	40	30
VE 3.0 hp	125A	FLA	78.8	71.0	37.9	32.5	76.4	71.0	37.9	31.2	71.8	68.3	34.6	25.9	49.8	48.8	25.0	17.7
	138W	WSA	98.5	88.6	46.7	40.6	81.3	75.9	40.4	32.9	87.1	83.0	42.1	31.4	54.7	53.7	27.5	19.4
	116G	MFCB	100	90	50	45	100	90	50	35	90	90	45	30	70	70	35	25
VE 5.0 hp	125A	FLA	84.9	76.6	40.7	34.7	82.5	76.6	40.7	33.4	77.9	73.9	37.4	28.1	55.9	54.4	27.8	19.9
	138W	WSA	106.1	95.6	50.2	43.4	87.4	81.5	43.2	35.1	93.2	88.6	44.9	33.6	60.8	59.3	30.3	21.6
	116G	MFCB	100	100	50	45	100	100	50	40	100	90	50	35	80	70	40	25
VE 7.5 hp	125A	FLA	92.4	83.4	44.1	37.6	90.0	83.4	44.1	36.3	85.4	80.7	40.8	31.0	63.4	61.2	31.2	22.8
	138W	WSA	115.5	104.1	54.5	47.0	96.1	88.9	46.8	38.5	101.8	96.0	48.5	37.0	69.5	66.7	34.0	25.0
	116G	MFCB	110	110	50	45	110	110	50	45	110	100	50	40	90	80	40	30
VE 10.0 hp	125A	FLA	99.0	89.4	47.1	39.6	96.6	89.4	47.1	38.3	92.0	86.7	43.8	33.0	70.0	67.2	34.2	24.8
	138W	WSA	123.7	111.6	58.2	49.5	104.3	96.4	50.6	41.0	110.1	103.5	52.2	39.5	77.7	74.2	37.7	27.5
	116G	MFCB	125	110	60	50	125	110	60	50	125	110	60	45	100	100	50	35
VE 5.0 hp	199A	FLA	114.3	108.9	54.4	44.7	99.7	93.8	48.7	42.2	114.3	108.9	54.4	42.5	73.1	71.6	35.8	28.7
	219W	WSA	140.9	132.3	66.5	55.9	106.7	100.9	52.2	45.0	138.7	132.3	66.1	51.6	80.2	78.7	39.3	31.5
	192G	MFCB	125	125	70	50	125	125	60	50	125	125	70	50	100	100	50	40

Table 12 GLYCOOL, dual cool VE models; 3 phase, 60 cycle (continued)

Reheat Options		Electric				None, Steam or Hot Water				Electric				None, Steam or Hot Water			
Humidifier Options		Infrared or Steam Generating*				Infrared or Steam Generating*				None				None			
Models / Motor HP	Volts	208	230	460	575	208	230	460	575	208	230	460	575	208	230	460	575
VE 7.5 hp	199A FLA	121.8	115.7	57.8	47.6	107.2	100.6	52.1	45.1	121.8	115.7	57.8	45.4	80.6	78.4	39.2	31.6
	219W WSA	150.2	139.1	70.7	59.5	114.2	107.7	55.6	47.9	146.2	139.1	69.5	54.5	87.7	85.5	42.7	34.4
	192G MFCB	150	150	70	50	125	125	60	50	150	150	70	50	110	110	50	45
VE 10.0 hp	199A FLA	128.4	121.7	60.8	49.6	113.8	106.6	55.1	47.1	128.4	121.7	60.8	47.4	87.2	84.4	42.2	33.6
	219W WSA	158.5	145.1	74.5	62.0	121.5	113.7	58.6	49.9	153.4	145.1	72.5	56.5	94.9	91.5	45.7	36.4
	192G MFCB	150	150	70	60	150	125	70	60	150	150	70	60	125	110	50	45
VE 15.0 hp	199A FLA	143.8	135.7	67.8	55.6	129.2	120.6	62.1	53.1	143.8	135.7	67.8	53.4	102.6	98.4	49.2	39.6
	219W WSA	177.7	162.6	83.2	69.5	140.7	131.1	67.3	57.3	172.2	162.6	81.2	63.9	114.2	108.9	54.5	43.8
	192G MFCB	200	175	90	70	175	150	80	70	200	175	90	70	150	150	70	60
VE 7.5 hp	245A FLA	139.3	136.6	67.9	53.3	122.8	116.2	58.2	49.0	139.3	136.6	67.9	53.3	96.2	94.0	46.6	37.4
	267W WSA	168.1	165.2	82.1	64.4	131.8	125.2	62.6	52.5	168.1	165.2	82.1	64.4	105.2	103.0	51.0	41.0
	240G MFCB	175	175	90	70	150	150	80	60	175	175	90	70	125	125	60	50
VE 10.0 hp	245A FLA	145.9	142.6	70.9	55.3	129.4	122.2	61.2	51.0	145.9	142.6	70.9	55.3	102.8	100.0	49.6	39.4
	267W WSA	174.7	171.2	85.1	66.4	138.4	131.2	65.7	54.5	174.7	171.2	85.1	66.4	111.8	109.0	54.0	43.0
	240G MFCB	175	175	90	70	150	150	80	60	175	175	90	70	125	125	70	50
VE 15.0 hp	245A FLA	161.3	156.6	77.9	61.3	144.8	136.2	68.2	57.0	161.3	156.6	77.9	61.3	118.2	114.0	56.6	45.4
	267W WSA	192.6	186.7	92.9	73.4	156.4	146.7	73.4	61.2	192.6	186.7	92.9	73.1	129.7	124.5	61.8	49.7
	240G MFCB	200	200	100	80	200	175	90	70	200	200	100	80	175	150	80	60
VE 20.0 hp	245A FLA	174.5	168.6	83.9	66.3	158.0	148.2	74.2	62.0	174.5	168.6	83.9	66.3	131.4	126.0	62.6	50.4
	267W WSA	209.1	201.7	100.4	79.6	172.9	161.7	80.9	67.5	209.1	201.7	100.4	79.3	146.2	139.5	69.3	55.9
	240G MFCB	225	225	110	90	225	200	100	80	225	225	110	90	200	175	90	70
VE 10.0 hp	380A FLA	171.6	164.4	78.7	63.6	171.6	164.4	76.8	63.6	167.0	163.7	78.7	61.6	145.0	142.2	65.2	52.0
	412W WSA	201.0	197.6	94.9	74.2	185.9	178.7	83.2	68.7	201.0	197.6	94.9	74.2	159.3	156.5	71.6	57.1
	363G MFCB	225	225	110	80	225	225	100	80	225	225	110	80	200	200	90	70
VE 15.0 hp	380A FLA	187.0	178.4	85.7	69.6	187.0	178.4	83.8	69.6	182.4	177.7	85.7	67.6	160.4	156.2	72.2	58.0
	412W WSA	216.4	211.6	101.9	80.2	201.3	192.7	90.2	74.7	216.4	211.6	101.9	80.2	174.7	170.5	78.6	63.1
	363G MFCB	250	225	110	90	250	225	110	90	250	225	110	90	225	225	100	80
VE 20.0 hp	380A FLA	200.2	190.4	91.7	74.6	200.2	190.4	89.8	74.6	195.6	189.7	91.7	72.6	173.6	168.2	78.2	63.0
	412W WSA	230.2	223.6	108.2	85.6	215.1	204.7	96.6	80.1	230.2	223.6	108.2	85.6	188.4	182.5	84.9	68.5
	363G MFCB	250	250	125	100	250	250	110	100	250	250	125	100	225	225	110	90

Standard unit with 0.5" external static pressure and standard cfm

1. FLA = Full Load Amps; WSA = Wire Sizing Amps; (Minimum supply circuit ampacity) MFCB = Maximum Fuse or Circuit Breaker Size
2. Amperage requirements are based on the rated max F.L.A. current of each component in the unit. The rated max FLA current of the unit is not the sum total of all components, but is the total of the components which operate during maximum electrical load conditions.
3. The values in the chart are for power of the VE unit only. The only electrical connection between the outside heat rejection equipment and the VE unit is low voltage control wires. An electrical source is required for the air cooled condenser (**Table 14**) or glycol pump and drycooler (**Tables 16 and 17**).

* When using steam generating humidifier on 6, 8, & 10 ton units, the electrical data is lower. Please consult Liebert for values.

Table 13 GLYCOOL or dual cooling DE models

Reheat Options			Electric				None				Electric				None			
Humidifier Options			Infrared or Steam Generating *				Infrared or Steam Generating *				None				None			
Models/Motor HP	Volts		208	230	460	575	208	230	460	575	208	230	460	575	208	230	460	575
DE 1.5 hp	72G	FLA	60.1	53.6	28.7	25.6	57.5	52.6	27.1	24.6	46.1	44.0	21.6	16.6	30.9	30.4	14.2	11.1
	75A	WSA	75.1	67.0	35.9	32.0	60.7	55.8	28.6	25.7	56.2	53.7	26.4	20.2	34.1	33.6	15.7	12.2
	86W	MFCB	80	60	40	35	70	60	30	30	60	50	25	20	45	45	20	15
DE 2.0 hp	110G	FLA	75.7	68.2	36.5	31.3	73.3	68.2	36.5	30.0	68.7	65.5	33.2	24.7	46.7	46.0	23.6	16.5
	114A	WSA	94.6	85.1	45.0	39.1	78.2	73.1	39.0	31.7	84.0	80.2	40.7	30.2	51.6	50.9	26.1	18.2
	127W	MFCB	90	90	45	40	90	90	45	35	90	90	45	30	70	70	35	25
DE 3.0 hp	116G	FLA	78.8	71.0	37.9	32.5	76.4	71.0	37.9	31.2	71.8	68.3	34.6	25.9	49.8	48.8	25.0	17.7
	125A	WSA	98.5	88.6	46.8	40.6	81.3	75.9	40.4	32.9	87.1	83.0	42.1	31.4	54.7	53.7	27.5	19.4
	138W	MFCB	100	90	50	45	100	90	50	35	90	90	45	30	70	70	35	25
DE 5.0 hp	192G	FLA	114.3	108.9	54.4	44.7	99.7	93.8	48.7	42.2	114.3	108.9	54.4	42.5	73.1	71.6	35.8	28.7
	199A	WSA	140.9	132.3	66.5	55.9	106.8	100.9	52.2	45.0	138.7	132.3	66.1	51.6	80.2	78.7	39.3	31.5
	219W	MFCB	125	125	70	50	125	125	60	50	125	125	70	50	100	100	50	40
DE 7.5 hp	240G	FLA	139.3	136.6	67.9	53.3	122.8	116.2	58.2	49.0	139.3	136.6	67.9	53.3	96.2	94.0	46.6	37.4
	245A	WSA	168.1	165.3	82.1	64.4	131.8	125.2	62.7	52.6	168.1	165.3	82.1	64.4	105.2	103.0	51.0	41.0
	267W	MFCB	175	175	90	70	150	150	80	60	175	175	90	70	125	125	60	50
DE 10.0 hp	363G	FLA	171.6	164.4	78.7	63.6	171.6	164.4	76.8	63.6	167.0	163.7	78.7	61.6	145.0	142.2	65.2	52.0
	380A	WSA	201.1	197.6	94.9	74.3	185.9	178.7	83.2	68.7	201.1	197.6	94.9	74.2	159.3	156.5	71.6	57.1
	412W	MFCB	225	225	110	80	225	225	100	80	225	225	110	80	200	200	90	70

1. FLA= Full Load Amps; WSA= Wire Sizing Amps (minimum supply circuit ampacity); MFCB = Maximum Fuse or Circuit Breaker Size
2. Amperage requirements are based on the rated max FLA current of each component in the unit. The rated max FLA current of the unit is not the sum total of all components, but is the total of the components that operate during maximum electrical load conditions.
3. The values in the chart are for power of the DE unit only. The only electrical connection between the outside heat rejection equipment and the DE unit is low voltage control wires. An electrical source is required for the air cooled condenser (Table 14) or glycol pump and drycooler (Tables 16 and 17).
4. Optional CFM ratings do not apply for units with steam or hot water reheat.

*When using steam generating humidifier on 6, 8, & 10 ton units, the electrical data is lower. Please consult Liebert for values.

ELECTRICAL DATA—OUTDOOR AIR COOLED CONDENSERS

Table 14 Outdoor air cooled condenser amperage

Indoor Unit	Air Cooled Condenser Model	Volts	Fan Speed Control (-20°F)				Lee-Temp (-30°F)			
			PH	FLA	WSA	OPD	PH	FLA	WSA	OPD
DH/VH 75A	CD104	208/230	1	4.8	6.0	15	3	4.0	5.0	15
		460*	1	2.5	3.1	15	3	2.5	3.1	15
		575*	1	1.9	2.4	15	3	1.4	1.8	15
DH/VH 114A	CD165	208/230	3	8.3	9.5	15	3	7.0	7.9	15
		460	3	4.2	4.8	15	3	3.4	3.8	15
		575	3	3.3	3.8	15	3	2.8	3.2	15
DH/VH 125A	CD165	208/230	3	8.3	9.5	15	3	7.0	7.9	15
		460	3	4.2	4.8	15	3	3.4	3.8	15
		575	3	3.3	3.8	15	3	2.8	3.15	15
DH/VH 199A	CD205	208/230	3	8.3	9.5	15	3	7.0	7.9	15
		460	3	4.2	4.8	15	3	3.4	3.8	15
		575	3	3.3	3.8	15	3	2.8	3.15	15
DH/VH 245A	CD308	208/230	3	11.8	13.0	15	3	10.5	11.4	15
		460	3	5.9	6.5	15	3	5.1	5.5	15
		575	3	4.7	5.2	15	3	4.2	6.0	15
DH/VH 290A	CD308	208/230	3	11.8	13.0	15	3	10.5	11.4	15
		460	3	5.9	6.5	15	3	5.1	5.5	15
		575	3	4.7	5.2	15	3	4.2	6.0	15
DH/VH 380A	CD415	208/230	3	15.3	16.5	20	3	14.0	14.9	15
		460	3	7.6	8.2	15	3	6.8	7.2	15
		575	3	6.1	6.6	15	3	5.6	6.0	15

1. 95°F Ambient Condensers
 2. FLA=Full Load Amps. WSA=Wire Sizing Amps (Minimum supply circuit ampacity) MFCB = Maximum Fuse on Circuit Breaker Size
- *Condenser equipped with step-down transformer and 208/230 motor.
 Data shown applies to the standard factory supplied condensers. These may vary in local areas and verification with your Liebert representative is strongly recommended.

Table 15 Lee-Temp receiver heater pads

All Air Cooled Models		
Volts	120	230
Watts/Pad	150	150
Total Amps (2 Pads)	2.5A	1.3A
WSA (2 Pads)	3.1	1.6
OPD (2 Pads)	15	15

1. Separate electrical source required for continuous operation of single phase silicone rubber heater pads for Lee-Temp.
2. Two pads are required for standard installations (one per circuit.)

Table 16 Outdoor glycol pump and drycooler electrical requirements (glycol units)

Unit		Drycooler			Pump			Total Pkg.		
Indoor Models	Drycooler Models	Volts	PH	FLA	HP	PH	FLA	FLA	WSA	MFCB
DH/VH 72G	D-112	208	3	3.5	1-1/2	3	6.6	10.1	11.8	15
		230	3	3.5	1-1/2	3	6.0	10.1	11.8	15
		460	3	1.7	1-1/2	3	3.0	4.7	5.5	15
		575	3	1.4	1-1/2	3	2.4	3.8	4.4	15
DH/VH 110G	D-174	208	3	7.0	1-1/2	3	6.6	13.6	15.3	20
		230	3	7.0	1-1/2	3	6.0	13.6	15.3	20
		460	3	3.4	1-1/2	3	3.0	6.4	7.2	15
		575	3	2.8	1-1/2	3	2.4	5.2	5.8	15
DH/VH 116G	D-174	208	3	7.0	1-1/2	3	6.6	13.6	15.3	20
		230	3	7.0	1-1/2	3	6.0	13.6	15.3	20
		460	3	3.4	1-1/2	3	3.0	6.4	7.2	15
		575	3	2.8	1-1/2	3	2.4	5.2	5.8	15
DH/VH 192G	D-260	208	3	10.5	2	3	7.5	18.0	19.9	25
		230	3	10.5	2	3	6.8	18.0	19.9	25
		460	3	5.1	2	3	3.4	8.5	9.4	15
		575	3	4.2	2	3	2.7	6.9	7.6	15
DH/VH 240G	D-310	208	3	10.5	3	3	10.6	21.1	23.8	30
		230	3	10.5	3	3	9.6	21.1	23.8	30
		460	3	5.1	3	3	4.8	9.9	11.1	15
		575	3	4.2	3	3	3.9	8.1	9.2	15
DH/VH 265G	D-350	208	3	10.5	3	3	10.6	21.1	23.8	30
		230	3	10.5	3	3	9.6	21.1	23.8	30
		460	3	5.1	3	3	4.8	9.9	11.1	15
		575	3	4.2	3	3	3.9	8.1	9.2	15
DH/VH 363G	D-466	208	3	14.0	5	3	16.7	30.7	34.9	50
		230	3	14.0	5	3	15.2	30.7	34.9	50
		460	3	6.8	5	3	7.6	14.4	16.3	20
		575	3	5.6	5	3	6.1	11.7	13.2	15

Notes to Tables 16 and 17

1. 95° ambient selections
2. Pump and drycoolers powered from same 3 phase feeder.
3. FLA=Full Load Amps; WSA=Wire Sizing Amps; MFCB=Maxium Fuse or Circuit Breaker Size
4. Values shown are for primary vendors—may change slightly for different source of supply.

Table 17 Glycol pump and drycooler electrical requirements (GLYCOOL units)

Unit		D.C.			Pump			Total Pkg.		
Indoor Model	Drycooler Model	Volts	PH	FLA	HP	PH	FLA	FLA	WSA	MFCB
DE/VE 72G	D-112	208	3	3.5	1-1/2	3	6.6	10.1	11.8	15
		230	3	3.5	1-1/2	3	6.0	10.1	11.8	15
		460	3	1.7	1-1/2	3	3.0	4.7	5.5	15
		575	3	1.4	1-1/2	3	2.4	3.8	4.4	15
DE/VE 110G	D-174	208	3	7.6	1-1/2	3	6.6	13.6	15.3	20
		230	3	7.6	1-1/2	3	6.0	13.6	15.3	20
		460	3	3.4	1-1/2	3	3.0	6.4	7.2	15
		575	3	2.8	1-1/2	3	2.4	5.2	5.8	15
DE/VE 116G	D-174	208	3	7.0	2	3	7.5	14.5	16.4	20
		230	3	7.0	2	3	6.8	14.5	16.4	20
		460	3	3.4	2	3	3.4	6.8	7.7	15
		575	3	2.8	2	3	2.7	5.5	6.2	15
DE/VE 192G	D-260	208	3	10.5	3	3	10.6	21.1	23.8	30
		230	3	10.5	3	3	9.6	21.1	23.8	30
		460	3	5.1	3	3	4.8	9.9	11.1	15
		575	3	4.2	3	3	3.9	8.1	9.1	15
DE/VE 240G	D-310	208	3	10.5	3	3	10.6	21.1	23.8	30
		230	3	10.5	3	3	9.6	21.1	23.8	30
		460	3	5.1	3	3	4.8	9.9	11.1	15
		575	3	4.2	3	3	3.9	8.1	9.2	15
DE/VE 363G	D-466	208	3	14.0	5	3	16.7	30.7	34.9	50
		230	3	14.0	5	3	15.2	30.7	34.9	50
		460	3	6.8	5	3	7.6	14.4	16.3	20
		575	3	5.6	5	3	6.1	11.7	13.2	15

Table 18 Electrical requirements per compressor

Unit	208V			230V			460V			575V		
	OA	RLA	LRA	OA	RLA	LRA	OA	RLA	LRA	OA	RLA	LRA
75A	10.2	12.6	82.0	9.2	12.6	82.0	4.6	5.8	41.0	3.7	4.5	28.4
114A	16.6	19.6	141.0	15.0	19.6	141.0	7.5	10.1	62.5	6.0	6.9	40.0
125A	18.4	19.6	141.0	16.6	19.6	141.0	7.8	10.1	62.5	6.2	6.9	40.0
199A	23.7	28.2	160.0	21.4	28.2	160.0	10.7	14.1	80.0	8.6	11.3	64.0
245A	28.7	36.0	198.0	26.0	36.0	198.0	13.0	17.8	99.0	10.4	14.2	79.0
290A	34.6	41.0	228.0	30.8	41.0	228.0	15.4	19.9	114.0	12.3	16.0	91.0
380A	49.2	57.1	266.0	44.5	57.1	266.0	22.3	25.6	120.0	17.8	20.5	96.0
86W	8.6	12.6	82.0	7.8	12.6	82.0	3.9	5.8	41.0	3.1	4.5	28.4
127W	13.9	19.6	141.0	12.6	19.6	141.0	6.3	10.1	62.5	5.0	6.9	40.0
138W	14.2	19.6	141.0	12.8	19.6	141.0	6.4	10.1	62.5	5.1	6.9	40.0
219W	19.9	28.2	160.0	18.0	28.2	160.0	9.0	14.1	80.0	7.2	11.3	64.0
267W	25.2	36.0	198.0	22.8	36.0	198.0	11.4	17.8	99.0	9.1	14.2	79.0
315W	30.1	41.0	228.0	27.2	41.0	228.0	13.6	19.9	114.0	10.9	16.0	91.0
412W	43.2	57.1	266.0	39.1	57.1	266.0	19.6	25.6	120.0	15.6	20.5	96.0
72G	11.3	12.6	82.0	10.2	12.6	82.0	5.1	5.8	41.0	4.1	4.5	28.4
110G	17.7	19.6	141.0	16.0	19.6	141.0	8.0	10.1	62.5	6.4	6.9	40.0
116G	18.8	19.6	141.0	17.0	19.6	141.0	8.5	10.1	62.5	6.8	6.9	40.0
192G	24.8	28.2	160.0	22.4	28.2	160.0	11.2	14.1	80.0	9.0	11.3	64.0
240G	31.0	36.0	198.0	28.0	36.0	198.0	14.0	17.8	99.0	11.2	14.2	79.0
265G	36.7	41.0	228.0	33.2	41.0	228.0	16.6	19.9	114.0	13.3	16.0	91.0
363G	53.5	57.1	266.0	48.6	57.1	266.0	24.3	25.6	120.0	19.4	20.5	96.0

OA— Operating Amps. This value is the actual operating amperage draw during normal operator of the unit for capacities as shown in the **Installation and Application Guidelines**.

LRA—Locked Rotor Amps

RLA—Rated Load Amps

Table 19 Indoor evaporator fan motor electrical requirements

Motor Hp	208		230		460		575	
	FLA	LRA	FLA	LRA	FLA	LRA	FLA	LRA
1.0 hp	4.0	24.8	3.6	21.6	1.8	10.8	1.4	8.4
1.5 hp	5.7	35.9	5.2	31.2	2.6	15.6	2.1	12.6
2.0 hp	7.5	46.9	6.8	40.8	3.4	20.4	2.7	16.2
3.0 hp	10.6	66.0	9.6	58.0	4.8	26.8	3.9	23.4
5.0 hp	16.7	105.0	15.2	91.0	7.6	45.6	6.1	36.6
7.5 hp	24.2	152.0	22.0	132.0	11.0	66.0	9.0	54.0
10.0 hp	30.8	193.0	28.0	168.0	14.0	84.0	11.0	66.0
15.0 hp	46.2	290.0	42.0	252.0	21.0	126.0	17.0	102.0
20.0 hp	59.4	321.0	54.0	290.0	27.0	145.0	22.0	116.0

Refer to **Air Cooled Data** on page 16, **Water Cooled Data** on page 18, **Glycol Cooled Data** on page 20 and **GLYCOOL Data** on page 22 for motor size on units.

GUIDE SPECIFICATIONS

1.0 GENERAL

1.1 Summary

These specifications describe requirements for a precision environmental control system. The system shall be designed to maintain temperature and humidity conditions in the rooms containing electronic equipment. The manufacturer shall design and furnish all equipment to be fully compatible with heat dissipation requirements of the room.

1.2 Design Requirements

The precision environmental control system shall be a Liebert self-contained, factory-assembled unit with (upflow) (downflow) air delivery. The system shall have a total cooling capacity of ___ BTU/ HR, (kW) with a sensible cooling capacity of ___ BTU/ HR (kW) based on an entering air temperature of ___ °F (°C) dry bulb and ___ °F (°C) wet bulb. The unit is to be supplied with ___ volt ___ ph ___ Hz electrical service.

1.3 Submittals

Submittals shall be provided with the proposal and shall include: Single-Line Diagrams; Dimensional, Electrical, and Capacity Data; Piping and Electrical Connection Drawings.

2.0 PRODUCT

2.1 Cabinet and Frame Construction

The frame shall be constructed of MIG welded tubular steel. It shall be painted using the autophoretic coating process for maximum corrosion protection. The exterior panels shall be insulated with a minimum 1" (25.4mm), 1.5 lbs (.68 kg) density fiber insulation. The main front panel shall have captive 1/4 turn fasteners. The main unit color shall be _____. The accent color shall be _____. The exterior panels shall be powder coated.

2.1.1 Heavy Gauge Panels on Upflow Units (Optional)

The exterior panels shall be 16 gauge steel for operation with high external static pressures.

2.2 Filter Chamber

2.2.1 Downflow Units

The filter chamber shall be an integral part of the system, located within the cabinet serviceable from the end of the unit or the top of the unit (if there is no plenum). The filters shall be rated not less than ___% efficiency (based on ASHRAE 52.1).

2.2.2 Upflow Units With Front and Bottom Return

The filter chamber shall be an integral part of the system, located within the cabinet, serviceable from the end of the unit. The filters shall be rated not less than ___% efficiency (based on ASHRAE 52.1).

2.2.3 Upflow Units With Rear Return

The filter units chamber shall be located on the back of the cabinet, serviceable from the end of the unit. The filters shall be rated not less than ___% efficiency (based on ASHRAE 52.1).

2.3 Fan Section

The fan section shall be designed for ___ CFM (m³h) at an external static pressure of ___ in. wg. (Pa). The fans shall be the centrifugal type, double width double inlet, and shall be statically and dynamically balanced as a completed assembly to a maximum vibration level of two mils in any plane. The shaft shall be heavy duty steel with self-aligning ball bearings with a minimum life span of 100,000 hours. The fan motor shall be ___ hp (kW) at 1750 RPM and mounted on an adjustable slide base. The drive package shall be multi-belt, variable speed, sized for 200% of the fan motor horsepower. The fans shall be located to draw air over the A-Frame coil to ensure even air distribution and maximum coil performance.

2.4 Humidifier

2.4.1 Infrared

The humidifier shall be of the infrared type consisting of high intensity quartz lamps mounted above and out of the water supply. The evaporator pan shall be stainless steel and arranged to be serviceable without disconnecting high voltage electrical connections. The complete humidifier section shall be pre-piped ready for final connection. The infrared humidification system shall use bypass air to prevent over-humidification of the computer room. The humidifier shall have a capacity of ___ lbs./hr. (kg/h). The humidifier shall be equipped with an automatic water supply system. The system has an adjustable water-overfeed to prevent mineral precipitation.

2.4.2 Steam Generating

The environmental control system shall be equipped with a steam generating humidifier that is controlled by the microprocessor control system. It shall be complete with disposable canister, all supply and drain valves, steam distributor, and electronic controls. The need to change canister shall be annunciated on the microprocessor control panel. The humidifier shall be designed to operate with water conductivity from 200–500 micromhos.

2.4.3 Steam Grid

The steam humidifier shall be the “Armstrong” steam separator type with an internal drying chamber and steam jacketed stainless steel distribution manifold. Complete system shall include a prepiped solenoid control valve, inverted bucket steam trap, and cleanable Y-strainer. All mechanical control components shall be located in a separate compartment, isolated from the air stream. The humidifier shall have a capacity of ___ lbs./hr. (kg/h) at ___ PSIG (kPa) steam supply pressure.

2.5 Reheat

2.5.1 Electric

The electric reheat coils shall be low watt density, 304/304 stainless steel fin tubular construction, protected by thermal safety switches, shall be ___ BTU/HR, ___ kW, controlled in three stages.

2.5.2 Steam

The steam reheat coil shall have copper tubes and aluminum fins with a capacity of ___ BTU/HR (kW) with ___ PSIG (kPa) steam. The system shall be factory pre-piped with a 2-way modulating control valve, Y-strainer, and F & T steam trap.

2.5.3 Hot Water

The hot water reheat coil shall have copper tubes and aluminum fins with a capacity of ___ BTU/HR (kW) when supplied with ___ °F (°C) entering water temperature at ___ GPM (l/s) flow rate. Maximum pressure drop shall be ___ PSI (kPa). The control system shall be factory prepiped with a 2-way modulating control valve and cleanable Y-strainer.

2.6 Advanced Control Processor

The Advanced control processor shall be microprocessor based with a front monitor LCD display panel and control keys for user inputs. The controls shall be menu driven with on-screen prompts for easy user operation. The system shall allow user review and programming of temperature and humidity setpoints, alarm parameters, and setup selections including choice of control type. A password shall be required to make system changes. For all user selections, the range of acceptable input (temperature, humidity, or time delay) shall be displayed on the monitor screen. The system shall provide monitoring of room conditions, operational status in % of each function, component run times, date and time, and four analog inputs from sensors provided by others.

Control

The control system shall allow programming of the following room conditions:

- Temperature Setpoint—65–85°F (18–29°C)
- Temperature Sensitivity—±1° to 9.9°F (0.6 to 5.6°C) in 0.1°F (.1°C) increments
- Humidity Setpoint—20–80% RH
- Humidity Sensitivity—+1% to +30% RH

All setpoints shall be adjustable from the individual unit front monitor panel. Temperature and Humidity Sensors shall be capable of being calibrated using the front monitor panel controls to coordinate with other temperature and humidity sensors in the room.

Predictive Humidity Control

The microprocessor shall calculate the moisture content in the room and prevent unnecessary humidification and dehumidification cycles by responding to changes in dew point temperature. In addition, the system shall provide the following internal controls:

Compressor Short-Cycle Control

The control system shall include a program to prevent compressor short cycling.

Automatic Compressor Sequencing

The microprocessor shall automatically change the lead/lag sequence of the compressors after each start to lengthen compressor-on cycles and even compressor wear.

System Auto-Restart

For start-up after power failure, the system shall provide automatic restart with a programmable (up to 9.9 minutes in 6-second increments) time delay. Programming can be performed either at the unit or from the central site monitoring system.

Sequential Load Activation

During start-up, or after power failure, the microprocessor shall sequence operational load activation to minimize inrush current. Systems allowing multiple loads to start simultaneously are unacceptable.

Hot Water/Econ-O-Coil Flush Cycles

Hot water coils and Econ-O-Coils shall be automatically flushed to prevent the buildup of contaminants. Systems without this feature shall include the necessary devices to bypass fluid into the coil on a programmed basis.

Front Monitor Display Panel

The microprocessor shall provide a front monitor LCD backlit display panel with 4 rows of 20 characters with adjustable contrast. This display (along with five front mounted control keys) shall be the only operator interface required to obtain all available system information such as room conditions, operational status, alarms, control and alarm set-points, and all user selections including alarm delays, sensor calibration, DIP switch selections, and diagnostics. All indicators shall be in language form. No symbols or codes shall be acceptable.

Alarms

The microprocessor shall activate an audible and visual alarm in event of any of the following conditions:

High Temperature

- Low Temperature
- High Humidity
- Low Humidity
- Short Cycle
- Compressor
- Overload (#1 and #2) (opt)
- Main Fan Overload (opt)
- Humidifier Problem
- High Head Pressure (#1 and #2)
- Change Filters
- Loss of Air Flow
- Low Suction Pressure
- Loss of Power
- Custom Alarm (#1 to #4)

Custom alarms are four customer accessible alarm inputs to be indicated on the front panel. Custom alarms can be identified with prepared (programmed) labels for the following frequently used inputs:

- Water Under Floor
- Smoke Detected
- Standby GC Pump On
- Loss of Water Flow
- Standby Unit On

User customized text can be entered for two of the four custom alarms.

Each alarm (unit and custom) can be separately enabled or disabled, selected to activate the common alarm, and programmed for a time delay of 0 to 255 seconds.

Audible Alarm

The audible alarm shall annunciate any alarm that is enabled by the operator.

Common Alarm

A programmable common alarm shall be provided to interface user selected alarms with a remote alarm device.

Remote Monitoring

All alarms shall be communicated to the Liebert site monitoring system with the following information: date and time of occurrence, unit number, and present temperature and humidity.

Control Type

The user shall be able to select the type of control the advanced microprocessor will use. Selections available shall be intelligent, proportional, and tunable PID (proportional, integral, and derivative gains). The intelligent control shall incorporate control logic that uses artificial intelligence techniques including “fuzzy logic” and “expert systems” methods to maintain precise, stable control. If tunable PID is selected, the user shall be able to program each of the three gains.

Analog Inputs

The system shall include four customer accessible analog inputs for sensors provided by others. The analog inputs shall accept a 4 to 20 mA signal. The user shall be able to change the input to 0 to 5 VDC or 0 to 10 VDC if desired. The gains for each analog input shall be programmable from the front panel. The analog inputs shall be able to be monitored from the front panel.

Diagnostics

The control system and electronic circuitry shall be provided with self-diagnostics to aid in troubleshooting. The microcontroller board shall be diagnosed and reported as pass/not pass. Control inputs shall be indicated as on or off at the front monitor panel.

Control outputs shall be able to be turned on or off from the front monitor panel without using jumpers or a service terminal.

Data Collection

The control system shall maintain accumulative operating hours of compressors, reheats, humidifier, fan motor and Econ-O-Coil. The ten most recent alarms shall also be retained.

Communications

The microprocessor shall be compatible with all Liebert remote monitoring and control devices.

2.7 Advanced Microprocessor Control With Graphics (Optional)

The optional advanced control processor shall be microprocessor based with a front monitor dot matrix display panel and control keys for user inputs. The controls shall be menu driven with on-screen prompts for easy user operation. The system shall allow user review and programming of temperature and humidity setpoints, alarm parameters, and setup selections including choice of control type. A password shall be required to make system changes. For all user selections, the range of acceptable input (temperature, humidity, or time delay) shall be displayed on the monitor screen. The system shall provide monitoring of room conditions, operational status in % of each function, component run times, date and time, and four analog inputs from sensors provided by others.

Control

The control system shall allow programming of the following room conditions:

- Temperature Setpoint—65–85°F (18–29°C)
- Temperature Sensitivity—+1° to + 9.9°F (°C) in 0.1°F (°C) increments
- Humidity Setpoint—20–80% RH
- Humidity Sensitivity—+1% to +30% RH

All setpoints shall be adjustable from the individual unit front monitor panel. The microprocessor can be set with these ranges, however, the unit may not be able to control to extreme combinations of temperature and humidity. Temperature and Humidity Sensors shall be capable of being calibrated using the front monitor panel controls to coordinate with other temperature and humidity sensors in the room.

Predictive Humidity Control

The microprocessor shall calculate the moisture content in the room and prevent unnecessary humidification and dehumidification cycles by responding to changes in dew point temperature. In addition, the system shall provide the following internal controls:

Compressor Short-Cycle Control

The control system shall prevent compressor short-cycling by a 3-minute timer from compressor stop to the next start.

Automatic Compressor Sequencing

The microprocessor shall automatically change the lead/lag sequence of the compressors after each start to lengthen compressor-on cycles and even compressor wear.

System Auto-Restart

For start-up after power failure, the system shall provide automatic restart with a programmable (up to 9.9 minutes in 6-second increments) time delay. Programming can be performed either at the unit or from the central site monitoring system.

Sequential Load Activation

During start-up, or after power failure, the microprocessor shall sequence operational load activation to minimize inrush current.

Systems allowing multiple loads to start simultaneously are unacceptable.

Hot Water/Econ-O-Coil Flush Cycles

Hot water coils and Econ-O-Coils shall be automatically flushed to prevent the buildup of contaminants. Systems without this feature shall include the necessary devices to bypass fluid into the coil on a programmed basis.

Front Monitor Display Panel

The microprocessor shall provide a front monitor 240 x 128 dot matrix graphics display panel with backlighting. This display (along with five front mounted control keys) shall be the only operator interface required to obtain all available system information such as room conditions, operational status, graphical data, alarms, control and alarm setpoints, and all user selections including alarm delays, sensor calibration, DIP switch selections, and diagnostics. All indicators shall be in language form. No symbols or codes shall be acceptable.

Alarms

The microprocessor shall activate an audible and visual alarm in event of any of the following conditions:

- High Temperature
- Low Temperature
- High Humidity
- Low Humidity
- Short Cycle
- Compressor
- Overload #1 and #2 (Opt)
- Main Fan Overload (Opt)
- Humidifier Problem
- High Head Pressure (#1 and #2)
- Change Filters
- Loss of Air Flow
- Low Suction Pressure
- Loss of Power
- Custom Alarm (#1 to #4)

Custom alarms are four customer accessible alarm inputs to be indicated on the front panel. Custom alarms can be identified with prepared (programmed) labels for the following frequently used inputs:

- Water Under Floor
- Smoke Detected
- Standby GC Pump On
- Loss of Water Flow
- Standby Unit On

User customized text can be entered for all four custom alarms.

Each alarm (unit and custom) can be separately enabled or disabled, selected to activate the common alarm, and programmed for a time delay of 0 to 255 seconds.

Audible Alarm

The audible alarm shall annunciate any alarm that is enabled by the operator.

Common Alarm A programmable common alarm shall be provided to interface user selected alarms with a remote alarm device.

Remote Monitoring

All alarms shall be communicated to the Liebert site monitoring system with the following information: date and time of occurrence, unit number, and present temperature and humidity.

Control Type

The user shall be able to select the type of control the advanced microprocessor will use. Selections available shall be intelligent, proportional, and tunable PID (proportional, integral, and derivative gains). The intelligent control shall incorporate control logic that uses artificial intelligence techniques including “fuzzy logic” and “expert systems” methods to maintain precise, stable control. If tunable PID is selected, the user shall be able to program each of the three gains.

Analog Inputs

The system shall include four customer accessible analog inputs for sensors provided by others. The analog inputs shall accept a 4 to 20 mA or 0 to 10 VDC signal. The user shall be able to change the input to 0 to 5 VDC if desired. The gains for each analog input shall be programmable from the front panel. The analog inputs shall be able to be monitored from the front panel.

Diagnostics

The control system and electronic circuitry shall be provided with self-diagnostics to aid in troubleshooting. The microcontroller board shall be diagnosed and reported as pass/not pass. Control inputs shall be indicated as on or off at the front monitor panel. Con-

trol outputs shall be able to be turned on or off from the front monitor panel without using jumpers or a service terminal.

Data Collection

The control system shall maintain accumulative operating hours of compressors, reheats, humidifier, fan motor, Econ-O-Coil, and heat rejection. The sixty most recent alarms shall also be retained.

Graphing

The control shall display the following graphical data:

- temperature, humidity, analog inputs
- component operating status by hour
- leak detection floor plan
- operating status

Communications

The microprocessor shall be compatible with all Liebert remote monitoring and control devices.

2.8 Compressorized Systems

2.8.1 Dual Refrigeration Systems

Each refrigeration circuit shall include hot gas mufflers, liquid line filter dryers, refrigerant sight glass with moisture indicator adjustable, externally equalized expansion valves, and liquid line solenoid valves.

2.8.2 Semi-Hermetic Compressors

The compressors shall be located in a separate compartment so they may be serviced during operation of the equipment. The compressor shall be semi-hermetic with a suction gas cooled motor, vibration isolators, thermal overloads, oil sight glass, manual reset high pressure switch, pump down low pressure switch, suction line strainer, reversible oil pumps for forced feed lubrication, a maximum operating speed of 1750 RPM, and a minimum EER of ____.

2.8.3 Four-Step Refrigeration System (Optional)

The environmental control system shall include cylinder unloaders on the semi-hermetic compressors. The unloaders shall be activated by solenoid valves which are controlled from the microprocessor control. In response to the return air temperature, the microprocessor control shall activate the unloader solenoids and the liquid line solenoids such that four stages of refrigeration cooling are obtained. The stages shall be: **1)** one compressor, partially loaded, **2)** two compressors partially loaded, **3)** one compressor partially loaded, one compressor fully loaded, **4)** two compressors fully loaded. On a call for dehumidification, the microprocessor control shall insure that at least one compressor is on full for proper humidity control.

2.8.4 A-Frame DX Coil

The evaporator coil shall be an A-Frame design and have ____ sq. ft. (m²) face area, ____ rows deep. It shall be constructed of copper tubes and aluminum fins and have a maximum face velocity of ____ ft. per minute (m/s) at ____ CFM (CMH). Refrigerant of each system shall be distributed throughout the entire coil face area. A stainless steel condensate drain pan shall be provided.

2.8.5 Air Cooled Systems

The Liebert manufactured air cooled condenser shall be the low profile, show speed, multiple direct drive, propeller fan type. The condenser shall balance the heat rejection of the compressor at ____ °F (°C) ambient. The condenser shall be constructed of aluminum and contain a copper tube, aluminum fin coil arranged for (horizontal) (vertical) air discharge.

Fan Speed Control Condenser

The winter control system for the air cooled condenser shall be Liebert Fan Speed Control. The variable speed motor shall operate from 0 to 230 volts single phase, 10 to 1050 RPM. It shall be designed with ball bearings, permanent lubrication, internal overload protection, 40°C rise at full speed, 65°C rise at 10 RPM. The control system shall be complete with transducers, thermostats and electrical control circuit, factory prepackaged in the integral condenser control box. The transducer shall automatically sense the highest head pressure of either operating compressor and control the variable speed fan on the air cooled condenser to properly maintain the head pressure. The fan speed control system shall provide positive start-up and operation in ambient temperature as low as -20°F (-28.9°C). The air cooled condenser shall have a ____ volt, ____ ph ____ Hz power supply.

Lee-Temp Winter Control System (Optional)

The winter control system for the air cooled condenser shall be Lee-Temp. The Lee-Temp system shall allow start-up and positive head pressure control with ambient temperatures as low as -30°F (-34.4°C). The Lee-Temp package shall include the following components for each refrigeration circuit: insulated receiver, pressure relief valve, head pressure three-way control valve, and rotalock valve for isolating the refrigerant charge. The Lee-Temp receiver shall be factory insulated and mounted ready for the field connection to the air cooled condenser. The Lee-Temp heater shall require a separate power supply of ____ volt, single phase.

Quiet-Line Condenser (Optional)

Fan motors shall be 12-pole, 570 RPM, equipped with rain shields and permanently sealed ball bearings. Motors shall include built-in overload protection. Motors shall be rigidly mounted on die-formed galvanized steel supports. Disconnect switch shall be a standard feature.

Air Cooled Condenser (Optional)

Disconnect Switch. Provide a disconnect switch factory mounted and wired to the condenser control panel, accessible from the exterior. (Standard on Quiet-Line).

2.8.6 Water Cooled Systems

Condenser

The water cooled condensers for each circuit shall be cleanable, shell-and-tube, counter flow with removable heads. Condensers shall be A.S.M.E. stamped for a maximum refrigerant pressure of 400 PSI at 200°F (2758 kPa at 93.3°C). The unit shall require ____ GPM (l/s) of ____ °F (°C) water and have a maximum pressure drop of ____ PSI (kPa).

Water Regulating Valve

The condenser shall be prepiped with a two-way regulating valve which is head pressure actuated.

Regulating Valves (Optional)

The water regulating valve shall be prepiped with head pressure actuated (3 way) (2 way with bypass) regulating valve.

Pressure Rating

The condenser water circuit shall be designed for a pressure of (150) (300) PSI.

Hot Gas Reheat (Optional)

The complete hot gas reheat system shall include a copper tube, aluminum fin coil, three-way solenoid valve, refrigeration check valve, and one stage of electric reheat rated at ____ kW. The capacity of the coil shall be ____ BTU/HR (kW).

2.8.7 Glycol Cooled

Condenser

The glycol cooled condenser for each circuit shall be counterflow, shell-and-tube. It shall be cleanable, with removable heads. The condensers shall be A.S.M.E. stamped for a maximum refrigerant pressure of 400 PSI at 200°F (2758 kPa at 93.3°C). The unit shall require ____ GPM (l/s) and have a maximum pressure drop of ____ ft. of water (kPa).

Glycol Regulating Valve

Each condenser shall be pre-piped with head pressure activated regulating valve and parallel bypass valve.

Three-Way Glycol Regulating Valve (Optional)

Each condenser shall be prepiped with a head pressure activated three-way regulating valve.

Pressure Rating

The condenser glycol circuit shall be designed for a pressure of (150) (300) PSI.

Drycooler

The drycooler shall be the low profile, slow speed, multiple direct drive, propeller fan type. The drycooler shall be constructed of aluminum and contain a copper tube aluminum fin coil with an integral electric control panel and disconnect switch. The drycooler shall be designed for ____ °F (°C) ambient.

Glycol Pump Package

This system shall be provided with a centrifugal pump mounted in a weatherproof and vented enclosure. The pump shall be rated for ____ GPM (l/s) at ____ feet of head (kPa), and operate on ____ volt, 3 phase, ____ Hz.

Dual Pump Package (Optional)

The dual pump package shall include pumps, enclosure, field mounted flow switch, and a separate factory wired control box (including a lead/ lag switch for the pumps). The standby pump shall automatically start upon failure of the lead pump. Each pump shall be rated for ____ GPM (l/s) at ____ feet of head (kPa).

Hot Gas Reheat (Optional)

The complete hot gas reheat system shall include a copper tube, aluminum fin coil, three-way solenoid valve, and refrigerant check valve. The capacity of the coil shall be ____ BTU/HR (kW).

2.8.8 GLYCOOL

Condenser

The glycol cooled condenser for each circuit shall be counterflow, shell-and-tube. It shall be cleanable, with removable heads. The condensers shall be A.S.M.E. stamped for a maximum refrigerant pressure of 400 PSI at 200°F (2758 kPa at 93.3°C). The unit shall require ____ GPM (l/s) and have a maximum pressure drop of ____ ft. of water (kPa).

Glycol Regulating Valve

Each condenser shall be prepiped with a head pressure activated three-way regulating valve.

Drycooler

The drycooler shall be the low profile, slow speed, multiple direct drive, propeller fan type. The drycooler shall be constructed of aluminum and contain a copper tube aluminum fin coil with an integral electric control panel and disconnect switch. The drycooler shall be designed for ____ °F (°C) ambient.

Glycol Pump Package

This system shall be provided with a centrifugal pump mounted in a weatherproof and vented enclosure. The pump shall be rated for ____ GPM (l/s) at ____ feet of head (kPa), and operate on ____ volt, 3 phase, ____ Hz.

Dual Pump Package (Optional)

The dual pump package shall include pumps, enclosure, field mounted flow switch, and a separate factory wired control box (including a lead/ lag switch for the pumps). The standby pump shall automatically start upon failure of the lead pump. Each pump shall be rated for ____ GPM (l/s) at ____ feet of head (kPa).

GLYCOOL Three-Way Control Valve

The GLYCOOL coil shall be equipped with a fully proportional 3-way control valve. This motorized control valve shall control the amount of flow to the GLYCOOL cooling coil and maintain constant temperature and relative humidity.

GLYCOOL Coil

Free cooling GLYCOOL coil shall be copper tube, aluminum fin coil located in the return air before the A-Frame evaporator coil.

A Cu-Ni coil must be specified whenever a GLYCOOL or Dual Cooling Source system is applied to a cooling tower loop or other open water system.

The GLYCOOL coil shall be rated at ____ BTU/HR (kW) sensible cooling capacity with a 45°F (7.2°C) entering glycol solution temperature. The GLYCOOL coil shall require ____ GPM (l/s) and the total unit pressure drop shall not exceed ____ feet of water (kPa), when in the Econ-O-Cycle mode of operation.

Pressure Rating

The condenser/GLYCOOL coil circuit shall be designed for a pressure of (150) (300) PSI.

2.8.9 Dual Cooling Source Systems

The dual cooling source system shall consist of an air or water cooled compressorized system with the addition of a chilled water coil, a modulating control valve, and a comparative temperature sensor. The system shall be able to function either as a modulating chilled water system or as a compressorized system, or a combination of both. The primary mode of cooling shall be chilled water. Switchover between the two cooling modes shall be performed automatically by the microprocessor control.

Dual Cooling Source Three-Way Control Valve

The water circuit shall include a 3-way modulating valve. The microprocessor positions the valve in response to room conditions. Cooling capacity will be controlled by bypassing chilled water around the coil. The modulating valve travel for dehumidification shall be proportional.

Dual Cooling Source Coil

The dual-cooling source coil shall be constructed with copper tubes and aluminum fins. It shall be located in the return air, before the A-Frame evaporator coil. The dual cooling source coil shall be rated at ____ BTU/HR (kW) sensible cooling capacity with 45°F (7.2°C) entering water temperature. The dual cooling source coil shall require ____ GPM (l/s) of chilled water and the pressure drop shall not exceed ____ PSI (kPa).

A Cu-Ni coil must be specified whenever a GLYCOOL or Dual Cooling Source system is applied to a cooling tower loop or other open water system.

2.9 Optional Specifications

The precision environmental control system shall be equipped with the following optional components.

Disconnect Switch (Non-Locking Type)

The manual disconnect switch shall be mounted in the high voltage section of the electrical panel. The switch shall be accessible with the door closed.

Disconnect Switch (Locking Type)

The manual disconnect switch shall be mounted in the high voltage section of the electrical panel. The switch shall be accessible from the outside of the unit with the door closed, and prevent access to the high voltage electrical components until switched to the "OFF" position.

Firestat

The firestat shall immediately shut down the environmental control system when activated. The firestat shall be mounted in the electrical panel with the sensing element in the return air.

Condensate Pump

The condensate pump shall have a minimum capacity of 100 GPH (378 l/h) at 20 ft. (58 kPa) head. It shall be complete with integral float switch, pump and motor assembly, and reservoir.

Liqui-TECT Sensors (Maximum two per unit)

Provide ____ (quantity) solid state water sensors under the raised floor.

Floor Stand

The floor stand shall be constructed of a heliarc welded tubular steel frame. The floor stand shall have adjustable legs with vibration isolation pads. The floor stand shall be ____ inches (mm) high.

Floor Stand Turning Vane

A factory-supplied, field-mounted turning vane shall be provided.

Temperature and Humidity Recorder

Provide a 7-day/24 hour temperature and humidity recorder of the full scope, two pen, surface mounted type with 100 recording charts, one red and one blue bottle of recording ink. Recorder shall have a 110V, single phase, ____ Hz power supply.

Smoke Detector

The smoke detector shall immediately shut down the environmental control system and activate the alarm system when activated. The smoke detector shall be mounted in the electrical panel with the sensing element in the return air compartment.

2.10 Comprehensive Monitoring Solutions

(For detailed Guide Specifications on these products, refer to information posted at www.liebert.com)

SiteScan Web System

SiteLink Module

OpenComms Nform

OpenComms NIC & Web Card (OC-NIC & OC-Web Card)

Environmental Discrete Outputs Card (ENV-DO)

Remote Contact Monitor

- RCM4

Autochangeover Controllers

- AC3
- RAC2-8

Universal Monitor

Leak Detection

- Direct Read Module
- Zone Sensor
- Spot Sensor

3.0 EXECUTION

3.1 Installation of Precision Air Conditioning Units

3.1.1 General

Install precision air conditioning units in accordance with manufacturer's installation instructions. Install units plumb and level, firmly anchored in locations indicated, and maintain manufacturer's recommended clearances.

3.1.2 Electrical Wiring

Install and connect electrical devices furnished by manufacturer but not specified to be factory mounted. Furnish copy of manufacturer's electrical connection diagram submittal to electrical contractor.

3.1.3 Piping Connections

Install and connect devices furnished by manufacturer but not specified to be factory mounted. Furnish copy of manufacturer's piping connection diagram submittal to piping contractor.

3.1.4 Field Quality Control

Start up mainframe coolant units in accordance with manufacturer's start up instructions. Test controls and demonstrate compliance with requirements. These specifications describe requirements for a computer room environmental control system. The system shall be designed to maintain temperature and humidity conditions in the rooms containing electronic equipment.

The manufacturer shall design and furnish all equipment to be fully compatible with heat dissipation requirements.

INSTALLATION AND APPLICATION GUIDELINES

Selecting the Critical Space Location

Selection of the Critical Space site requires evaluation and consideration of many factors. These include the proximity of the Critical Space to related operations, security, interior vs. exterior zones of the building and proximity of the packaged environmental control system to the outdoor air cooled condenser, cooling tower or drycooler. In general, the location of the Critical Space should be in an area of the building which is not affected by outside temperatures or relative humidities. If a site is chosen with an outside wall, the area of window glass should be kept to a minimum and double or triple-glazed glass should be used to prevent condensation in winter.

Room Preparation

When designing the Critical Space, consideration should be given to accessibility and dimensional requirements for the environmental control equipment as well as the electronic equipment. This includes checking the size of door openings, elevator capacities and, in the case of a raised floor application, selecting a flooring system capable of supporting all the hardware. Consideration should also be given to the type of electrical power distribution and control system to be used in the Critical Space.

Sufficient area for any planned growth of the Critical Space and redundancy in environmental control units should be considered during initial planning.

The room should be well insulated and must have a sealed vapor barrier. The ceiling or ceiling plenum must be sealed as a false ceiling provides no protection from vapor migration. Use a rubber Installation/Application Guidelines or plastic base paint on concrete walls or floors to prevent moisture migration. Doors should not be undercut or have grilles in them. Light fixtures which require room air to cool them and allow room air to enter the area above the false ceiling should not be used when the false ceiling area is not a part of the site air distribution plan.

Outside air should be kept to an absolute minimum. Fresh air adds to the heating, cooling, humidifying and dehumidifying loads of the site. It is recommended that outside air be kept below 5% of the total air circulated in the space because of the small quantity of people who will be working in the site.

Installation of a Downflow Environmental Control System

The indoor packaged system can be installed on an accessible raised floor system. It may be necessary to furnish additional pedestal support under the unit to ensure maximum structural support. Or a separate floor stand for the unit may be used as support, independent of the raised floor, and installed prior to the

flooring system (see **Optional Equipment—All Systems**). The use of the floor stand permits the environmental control system to be installed, piped, wired and inspected prior to the installation of the raised floor.

This permits much easier access to all underfloor piping and wiring and would enable the construction to be completed in the least amount of time. The floor stand further provides vibration isolation from the adjacent raised floor and eliminates the need for cutting special openings in the floor panels under the unit. All field piping and electrical enter the unit from the bottom of the unit at the left end.

Provide approximately 34" (86 cm) service clearance on the left, right and in front of the unit whenever possible. The minimum space required for installation is 24" (61 cm) on the left end, 24" (61 cm) on the right end (0" for downflow air cooled units) and 24" (61 cm) in front of the unit.

This space is necessary to provide for routine maintenance such as replacing filters, adjusting the fan speed and cleaning the humidifier.

Note: If 6" filters are used, 25" (63.5 cm) is required on the right end for removal and replacement of filters.

Air Distribution of Downflow Systems

For underfloor air distribution, observe the following guidelines:

1. Avoid locating units in an alcove or at the extreme end of a room which has a high aspect ratio (long narrow room).
2. Avoid locating units too close to each other. Units located relatively close to each other tend to reduce the effectiveness of air distribution.
3. Select the air supply grilles and perforated panels for the raised floor to ensure minimum loss of pressure in the circuit. Air volume dampers on grilles, which extend several inches below the surface of the raised floor, are usually detrimental to air flow. Consideration of the height of the damper on the grille in conjunction with the floor height will determine whether this type of grille may be used.
4. The grilles used in raised floors vary in size, the largest being approximately 18" x 6" (45.7 RHx 15.2 cm). A larger grille size would be detrimental to the structural capacity of the raised floor panel. An 18" x 6" (45.7 x 15.2 cm) heavy duty pencil proof type grille typically has 56 square inches (361 cm²) of free area.

5. Perforated panels are available from various manufacturers of raised floors. These panels are usually 2' x 2' (.61m x .61m) square and have a nominal free area of approximately 108 to 144 square inches (697 to 929cm²). Use caution in selecting perforated panels as some manufacturers have only 36 to 40 square inches (232 to 258cm²) of free area, requiring four times as many panels.
6. Always check specifications of the floor supplier before specifying the total number of perforated panels and grilles required to handle the air flow. The proper specifications for grilles and perforated panels should indicate the total free area required for air delivery rather than the number of panels and grilles. (See **Table 20** for recommended free area required for each Liebert model.) **Table 20** below indicates the recommended free area based on having the supply air grilles and perforated panels sized to handle approximately 75% of the total CFM (CMH) of the units at a velocity of 550 to 600 ft/mm. (2.8 to 3.1 m/s). The remaining 25% of the air flow in the computer room raised floor passes through cable cutouts, cracks between the panels, and other leakage areas.

Table 20 Recommended free area (ft²) for grilles or perforated panels

Model	Model	Model	550 fpm	600 fpm
DH-75A	DH-86W	DH-72G	4.6	4.2
DH-114A	DH-127W	DH-110G	6.3	5.8
DH-125A	DH-138W	DH-116G	7.7	7.1
DH-199A	DH-219W	DH-192G	11.5	10.5
DH-245A	DH-267W	DH-240G	13.9	12.8
DH-290A	DH-315W	DH-265G	16.4	15.0
DH-380A	DH-412W	DH-363G	20.4	18.8

7. The decision to use a grille or a perforated panel depends on several factors. Perforated panels are generally used in the computer room near the hardware. Grilles with adjustable dampers should be used in areas where “people comfort” is a prime consideration, such as: keypunch areas, areas around the line printer, or other operator areas. This will allow the personnel to adjust the flow rates for their comfort rather than the equipment loads. Caution should be used when applying dampered grilles or dampered perforated panels around high heat gain areas to ensure that the dampers are not closed-off by shuffling of cables, occasional operator discomfort, or carelessness.
8. Avoid low floor elevations (below 7-1/2" / 90.5 mm), loosely installed flooring systems, and below floor obstructions, such as: electrical wiring chases, unusual length of computer system cables, or piping clusters.

Installation of an Upflow Environmental Control System

The indoor packaged system can be installed on an accessible raised floor system as described for a downflow system or on a solid nonraised floor. It can be installed inside the Critical Space or outside the Critical Space. A typical installation within the space can be accomplished without using any ductwork.

The packaged system should have a front-return cabinet (or bottom return if air cooled on a raised floor) with an optional front discharge plenum which sits on top of the unit. If supply air must be ducted to several locations within the space, duct flanges are provided on the blower discharges to attach the ductwork.

A decorative plenum is available in different heights to conceal the ductwork between the unit and ceiling. The packaged system can be installed outside the space and ducted in and out of the space. In this case, the unit should have a rear return with duct connections for the return air. Supply air ductwork should be attached to the blower discharges as described above. All field piping and electrical enter the unit on the lower left corner of the unit’s left end.

Provide approximately 34" (86cm) service clearance on the left, right and in front of the unit whenever possible. The minimum space required for installation is 24" (61cm) on the left end, 24" (61cm) on the right end and 24" (61cm) in front of the unit. This space is necessary to provide for routine maintenance such as replacing filters, adjusting the fan speed and cleaning the humidifier. Note: If 6" filters are used, 25" (63.5cm) is required on the right end for removal and replacement of filters.

Electrical Requirements for the Environmental Control System

Three-phase electrical service is required for all models in 208, 230, 460, or 575 volt 60 Hz.)

Electrical service to the unit should conform with both national and local electrical codes. Select the proper wire size for minimum allowable voltage drops to assure dependable operation during periods of peak power usage when “brownouts” may occur. See Wire Size Amp values in the **Electrical Specifications** section.

A manual electrical disconnect switch should be installed within 5 ft. (1.5 m) of the unit in accordance with codes or a disconnect switch may be factory supplied, mounted within the unit, accessible from the exterior with a locking or non-locking type of operating handle. (see **Optional Equipment—All Systems**). For emergency shut-down of each environmental control system through fire detection systems, panic buttons, etc., utilize the low voltage terminal strip located within each unit.

Liebert Air Cooled Environmental Control System

The Liebert air cooled environmental control system is shipped with a separate air cooled condenser. The refrigerant piping must be connected in the field and then be dehydrated and charged.

Other services required to make it operational are: 1) Electrical supply to the indoor unit; 2) Electrical supply to the air cooled condenser; 3) Condensate and Humidifier drain line and 4) Water source for the humidifier.

Installation of the Air Cooled Condenser

The air cooled condenser should be located for maximum security and maintenance accessibility. Avoid ground level sites with public access or areas which contribute to heavy snow or ice accumulations. Utilize centrifugal condensers whenever interior building locations must be used.

To assure adequate air supply, it is recommended that condensers be located in a clean air area, away from loose dirt and foreign matter that may clog the coil. In addition, condensers must not be located in the vicinity of steam, hot air or fume exhausts. Also, condensers should be located no closer than 3 feet (1 meter) from a wall, obstruction or adjacent unit.

Install condensers in a level position to assure proper refrigerant flow and oil return. Condenser legs have mounting holes for securing the condensers to steel supports or concrete pad. For roof installations, mount condensers on steel supports in accordance with local codes. For ground installations, a concrete pad is sufficient to provide adequate support.

Electrical service is required for all air cooled condensers at the location of the condenser. This power supply does not necessarily have to be the same voltage supply as required by the indoor unit. This separate power supply may be 208, 230, 460 or 575 volt 60 hertz. For electrical characteristics of the standard matching voltage condensers, see Full Load Amps values in **Table 14 - Outdoor air cooled condenser amperage**. The only electrical connection between the indoor unit and the air cooled condenser is a two wire control interlock, which is field connected.

Piping Considerations

All refrigeration piping should be installed with high temperature brazed joints. Prevailing good refrigeration practices should be employed for piping supports, leak testing, dehydration and charging of the refrigeration circuits.

The refrigeration piping should be isolated from the building by the use of vibration isolating supports.

Traps should be installed in the hot gas lines vertical risers with any rise over 5 feet (1.5m). If the rise

exceeds 25 feet (7.5m), traps should be installed in 20-foot (6m) increments or at evenly divided distances. These traps will collect condensed refrigerant and refrigerant oil during the off cycle of the unit and ensure the flow of refrigerant oil during operation. Inverted traps should be installed at the air cooled condenser to prevent refrigerant migration.

Factory approval is required whenever a refrigerant piping run exceeds 200 feet (60 meters) equivalent length or when condensers must be located below the level of the cooling coil.

For downflow systems, all piping below the raised floor must be located so that it offers the least resistance to air flow discharging from the system. Careful planning of the piping layout under the raised floor is required to prevent the air flow from being blocked from any portion of the room. When installing piping on the raised floor, it is recommended that the pipes be mounted in a horizontal fashion on the same elevation plane rather than stacked one above the other on support brackets.

Whenever possible, the pipes should be run parallel to the air flow. All condensate and unit drain lines should be trapped and pitched.

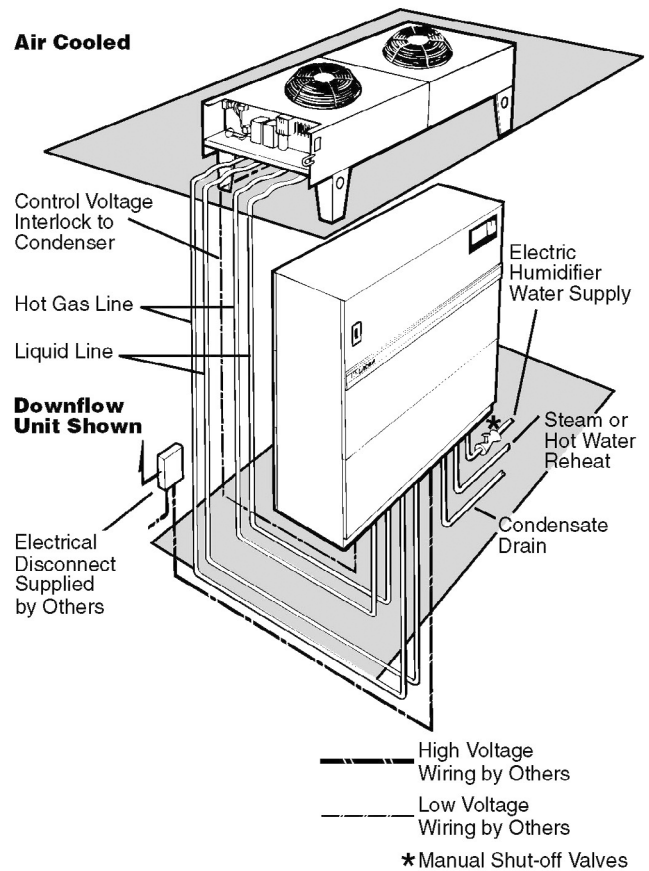

Liebert Water Cooled Environmental Control System

The Liebert water cooled environmental control system is shipped as a complete prepackage system. The refrigeration system is complete and factory charged, ready for operation. Other services required to make it operational are: 1) Electrical supply to the indoor unit; 2) Water source for the condensers; 3) Condensate and Humidifier drain line and 4) Water source for the humidifier.

Piping Considerations

Each environmental control unit contains a water cooled condenser for each refrigeration circuit. The supply and return lines to the water cooled condensers are manifolded together to provide one supply and one return line customer connection. It is recommended that manual service shut-off valves be installed at the supply and return line to each unit. This will provide for routine service or emergency isolation of the unit.

When the water source for the condenser is of poor quality, it is good practice to provide cleanable filters in the supply line. These filters will trap the particles in the water supply and extend the service life of the water cooled condensers.

When required, the water cooled condensers may be cleaned by removing the heads and rodding the tubes of the condensers. The condensers may also be acid cleaned, however, acid is generally not permitted in computer room locations.

Consideration of the minimum water temperature to be supplied from the cooling tower or other water source will determine if the need exists to insulate the condenser supply and return lines. Insulation will prevent condensation on the water lines.

WATER COOLED

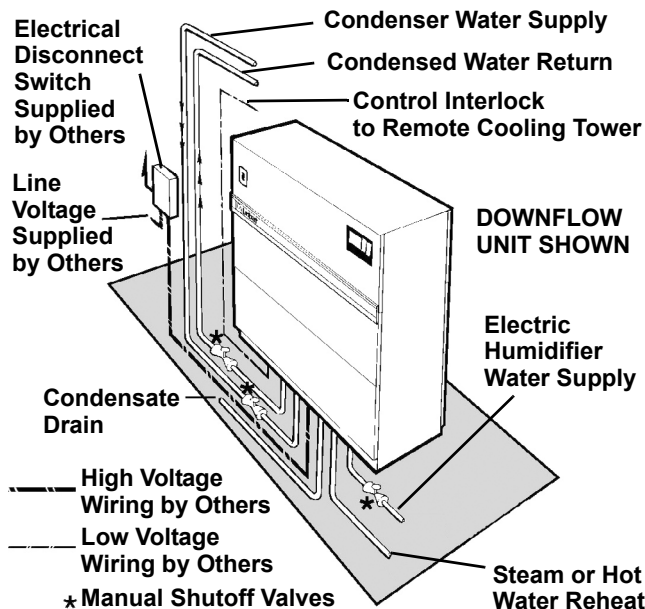

To provide for the emergency of water leaks, floor drains should be provided with wet traps or a “free-water” detection system such as the Liebert Liqui-tect alarm should be installed.

For downflow units, piping below the raised floor must be located so that it offers the least resistance to air flow discharging from the system. Careful planning of the piping layout under the raised floor is required to prevent the air flow from being blocked from any portion of the room. When installing piping on the subfloor, it is recommended that pipes be mounted in a horizontal fashion on the same elevation plane rather than stacked one above the other on support brackets. Whenever possible, the pipes should be run parallel to the air flow. All condensate and unit drain lines should be trapped and pitched.

Liebert Glycol Cooled Environmental Control System

The Liebert glycol cooled environmental control system is shipped as a complete prepacked system. The refrigeration circuit is complete and factory charged, ready for operation. Other services required to make it operational are: 1) Electrical supply to the indoor unit; 2) Glycol source for the condensers; 3) Condensate and Humidifier drain line and 4) Water source for the humidifier.

Piping Considerations

Each environmental control unit contains a glycol cooled condenser for each refrigeration circuit. The supply and return lines to the condensers are manifolded together to provide one supply and one return line customer connection. It is recommended that manual service shut-off valves be installed at the supply and return line of each unit. This will provide for routine service or emergency isolation of the unit. When required, the glycol cooled condensers may be cleaned by removing the heads and rodding the tubes of the condensers. The condensers may also be acid cleaned, however, acid is generally not permitted in computer room locations.

Consideration of the minimum glycol temperature to be supplied from the drycooler will determine if the need exists to insulate the condenser supply and return lines. Insulation will prevent condensation on the glycol lines in low ambient conditions.

To provide for the emergency of water leaks, floor drains should be provided with wet traps or a “free-water” detection system such as the Liebert Liqui-tect alarm should be installed.

For downflow units, piping below the raised floor must be located so that it offers the least resistance to air flow discharging from the system. Careful planning of the piping layout under the raised floor is required to prevent the air flow from being blocked from any portion of the room. When installing piping on the subfloor, it is recommended that pipes be

mounted in a horizontal fashion on the same elevation plane rather than stacked one above the other on support brackets. Whenever possible, the pipes should be run parallel to the air flow. All condensate and unit drain lines should be trapped and pitched.

Installation of the Drycooler

Locate the drycoolers for maximum effective security as well as best access for maintenance. Avoid site locations with public access or areas which will contribute to heavy snow or ice accumulations.

To ensure adequate air supply, it is recommended that drycoolers be located in a clean air area, away from loose dirt and foreign matter that may clog the coil. In addition, drycoolers must not be located in the vicinity of steam, hot air or fume exhausts. Also, drycoolers should be located no closer than 3 feet (1 meter) from a wall, obstruction or adjacent unit.

Locate the pump near the drycooler and the expansion tank at the highest point in the system. The drycooler has mounting holes in the legs to secure it in position. For roof installations, mount drycoolers on steel supports across load bearing walls in accordance with local codes. For ground installations, a concrete pad is sufficient to provide support.

Electrical service is required for all drycoolers at the location of the outdoor system. The power supply does not necessarily have to be the same voltage supply as required by the indoor unit. This separate power supply may be 208, 230, 460 or 575 volt, 60 Hz. For electrical characteristics of the standard matching voltage drycoolers, see Full Load Amps in **Table 16 - Outdoor glycol pump and drycooler electrical requirements (glycol units)**.

The only electrical connection between the indoor unit and the drycooler is a two wire control interlock which is field connected.

Glycol/Inhibitor Solution

The percentage of glycol to water will be determined by the outdoor ambient in which the system is operating. Just as critical, is the inhibitor used with the glycol. Commercial ethylene glycol (DuPont Telar, Union Carbide Ucar Thermofluid 17 and Dow Chemical Dowtherm SR-1), when pure, is generally less corrosive to the common metals of construction than water itself. It will, however, assume the corrosivity of the water from which it is prepared and may become increasingly corrosive with use if not properly inhibited. Proper inhibitor maintenance must be performed in order to prevent corrosion of the glycol system. We would recommend a chemical treatment such as Betz Inhibitor 590 or Betz Entec equivalent as recommended and manufactured by Betz Laboratories, Inc. Automotive anti-freeze is unacceptable and must not be used in an environmental control system.

GLYCOOL Application Notes

When using a glycol solution as a heat rejection and/or cooling fluid for heat transfer, special consideration must be given to pipe sizing and pump selections to insure proper operation. The viscosity, and therefore the pressure drop of glycol solutions, depend heavily on two factors. They are the concentration of the solution (30%, 40%, etc.) and the temperature of the solution.

When using glycol for the GLYCOOL systems, a concentration of 40% is normally selected. This provides freeze protection to approximately -15°F (-26°C). As compared to water, 40% glycol at 110°F (43°C) has a pressure drop approximately 15% greater for equivalent flow rates in SCH 40 steel pipe. When the temperature of the 40% solution falls to a 40°F (4.4°C) level, the pressure drop is 41% greater than water. The exact amount of increase depends on the actual pipe size and type, fluid velocity, temperature, and concentration. Consult glycol fluid supplier for complete information.

The pressure drop information for Liebert GLYCOOL systems are calculated for 40% Dowtherm SR-1 glycol, at 40°F (4.4°C) average solution temperature. This will be the condition of maximum pressure drop at the design flow rates for the GLYCOOL units and drycoolers. When selecting a pump for glycol solutions, the performance of a centrifugal pump is affected by the viscosity and specific gravity of the fluid. Glycol in the range of 20-50% concentration, and temperatures of 40°F to 110°F (4.4°C to 43°C), affect the performance curves less than 1%, and standard water pump curves can be used without modification.

When using the GLYCOOL system, all glycol piping inside of the building should be insulated to prevent sweating on the piping during the Econ-O-Cycle when the fluid temperature drops to 40°F (4.4°C).

These considerations are included in the Liebert GLYCOOL standard system design. The pump selections indicated, at the design flow rate, are tabulated with the total head capability of the pump. Deduct from this value the factory supplied unit and drycooler pressure drop at 40% and 40°F (4.4°C). The result is the amount of head available for field piping pressure drop. Field piping pressure drops, when calculated at 40%, 40°F (4.4°C) glycol solution, less than or equal to the available pressure from the pump, do not require a special factory pump selection.

When the anticipated field pressure drops exceeds the available, or multiple units are connected to a common set of risers to a large roof mounted drycooler, consult the factory for special pump selections.

Ensuring The High Availability Of Mission-Critical Data And Applications.

Emerson Network Power, the global leader in enabling business-critical continuity, ensures network resiliency and adaptability through a family of technologies—including Liebert power and cooling technologies—that protect and support business-critical systems. Liebert solutions employ an adaptive architecture that responds to changes in criticality, density and capacity. Enterprises benefit from greater IT system availability, operational flexibility and reduced capital equipment and operating costs.

Technical Support / Service Web Site

www.liebert.com

Monitoring

800-222-5877

monitoring@emersonnetworkpower.com

Outside the US: 614-841-6755

Single-Phase UPS

800-222-5877

upstech@emersonnetworkpower.com

Outside the US: 614-841-6755

Three-Phase UPS

800-543-2378

powertech@emersonnetworkpower.com

Environmental Systems

800-543-2778

Outside the United States

614-888-0246

Locations

United States

1050 Dearborn Drive

P.O. Box 29186

Columbus, OH 43229

Europe

Via Leonardo Da Vinci 8

Zona Industriale Tognana

35028 Piove Di Sacco (PD) Italy

+39 049 9719 111

Fax: +39 049 5841 257

Asia

7/F, Dah Sing Financial Centre

108 Gloucester Road, Wanchai

Hong Kong

852 2572220

Fax: 852 28029250

While every precaution has been taken to ensure the accuracy and completeness of this literature, Liebert Corporation assumes no responsibility and disclaims all liability for damages resulting from use of this information or for any errors or omissions.

© 2006 Liebert Corporation

All rights reserved throughout the world. Specifications subject to change without notice.

® Liebert and the Liebert logo are registered trademarks of Liebert Corporation. All names referred to are trademarks or registered trademarks of their respective owners.

SL-18100_REV1_08-06

Emerson Network Power.

The global leader in enabling Business-Critical Continuity™.

■ AC Power Systems

■ Embedded Computing

■ Outside Plant

■ Services

■ Connectivity

■ Embedded Power

■ Power Switching & Control

■ Site Monitoring

■ DC Power Systems

■ Integrated Cabinet Solutions

■ Precision Cooling

■ Surge Protection

EmersonNetworkPower.com

Business-Critical Continuity, Emerson Network Power and the Emerson Network Power logo are trademarks and service marks of Emerson Electric Co.

©2006 Emerson Electric Co.