

REPRODUCTION

MULTI TAPE LISTER A BLOCK 1025A

A. PURPOSE.

TO TEST FOR TAPE SKEW AND PERFORM RIPPLE PRINT.

B. LOADING PROCEDURES.

SEE GENERAL DESCRIPTION. THIS TEST CAN BE RUN ONLY FROM CARDS.

C. PROGRAM CONTROL.

SEE GENERAL DESCRIPTION.

SENSE SWITCH C ON CAUSES PRINTING OF A SINGLE 1 AT THE RIGHT EDGE OF THE TAPE INSTEAD OF THE TRIANGLE PATTERN IN ROUTINE 1.

FOUR ALTERATION DIGITS MAY BE USED TO CONTROL THE PROGRAM AS FOLLOWS-

- 1 IN 1129 SETS THE PROGRAM FOR USE WITH 8 NARROW TAPES
- 2 IN 1129 SETS THE PROGRAM FOR USE WITH 4 WIDE TAPES
- WM IN 1131 CAUSES PROGRAM TO DO ROUTINE 1
- NO WM IN 1131 CAUSES PROGRAM TO SKIP ROUTINE 1
- WM IN 1132 CAUSES PROGRAM TO DO ROUTINE 2
- NO WM IN 1132 CAUSES PROGRAM TO SKIP ROUTINE 2
- WM IN 1130 CAUSES PROGRAM TO USE C.E. PORTION OF TAPE SELECT TABLE
- NO WM IN 1130 CAUSES PROGRAM TO USE PRESET PORTION OF TAPE SELECT TABLE

D. TEST PROCEDURE.

ROUTINE 1- A 1 FROM THE BLANKS ONES TABLE IS MOVED INTO THE PRINT AREA OF THE FIRST TAPE. THIS TAPE IS THEN SELECTED AND A PRINT OP IS PERFORMED. IF SENSE SWITCH C IS ON, THIS PROCESS IS REPEATED ON THE NEXT TAPE. IF SENSE SWITCH C IS OFF THE ABOVE PROCESS IS REPEATED INCREASING THE NUMBER OF ONES BY ONE EACH TIME. WHEN THE LEFT MOST PRINTABLE POSITION PRINTS A 1, THE ABOVE IS REPEATED ON THE NEXT TAPE. WHEN THE LAST TAPE HAS BEEN PROCESSED, THE ENTIRE ROUTINE IS REPEATED UNDER COUNTER CONTROL. THE RESULT IS TEN TRIANGULAR PATTERNS OF ONES ON EACH TAPE.

ROUTINE 2- FOUR TAPE SELECT OPS ARE INSERTED IN THE PROGRAM FROM THE TAPE SELECT TABLE -LOC. /65 THROUGH S44-. THESE TAPE PRINT AREAS ARE LOADED FROM THE RIPPLE TABLE -LOC. T02 THROUGH T62-. THE RIPPLE TABLE IS RIGHT SHIFTED ONE POSITION BY MOVING THE RIGHT MOST CHARACTER TO THE LEFT MOST POSITION OF THE TABLE. THEN ALL OTHER CHARACTERS ARE MOVED ONE POSITION TO THE RIGHT. THE FOUR TAPES ARE THEN SELECTED AND A PRINT OP PERFORMED. THE ABOVE IS REPEATED UNTIL FIFTY LINES OF RIPPLE ARE PRINTED. IF THE TAPES WERE SELECTED FROM THE C.E. PORTION OF THE TAPE SELECT TABLE -LOC. S29 THROUGH S44-, THIS ENDS THE ROUTINE. IF THE TAPES WERE SELECTED FROM THE PRESET PORTION OF THIS TABLE -LOC. /65

DATE	9/17/63	4-23-63	25.6.63				
ENG. CHG. NO.	116745	117487	TA-1844A				

DIAGNOSTIC FUNCTION TEST

REPRODUCTION

THROUGH 528-, THE ABOVE IS REPEATED ON OTHER TAPES. THE TAPES ARE SELECTED FROM THE PRESET PORTION OF THIS TABLE THE PRINTING OCCURS IN THE FOLLOWING SEQUENCE -THE FIRST FOUR, THE LAST FOUR, -THEN, ONLY IF NARROW TAPES- THE ODD FOUR, THE EVEN FOUR.

NOTE - TO USE THE C.E. PORTION OF THE TABLE THE N OPS SHOULD BE CHANGED TO F OPS FOR THOSE TAPES TO BE SELECTED.

E. STOPS.

INSTR.	STORAGE
ADDR.	ADDR. REG.
412	413

TO ADJUST ALTERATION DIGITS.

F. SAMPLE PRINTOUT.

1	ROUTINE 1
11	..
111	..
.....	..
.....	..
111111111111	..
1	..
11	..
111	..
.....	..
.....	..
111111111111	..
5678 9/-, .60	ROUTINE 2
5678 9/-, .3	..
4 5678 9/, .	..
34 5678 9/-,	..
234 5678 9/-,	..
1234 5678 9/-	..

NOTE- THIS IS A SAMPLE. THE PRINT OUT VARIES WITH THE SIZE TAPE USED. SEE THE ABOVE DESCRIPTION.

G. COMMENTS.

DUE TO THE CHARACTER OF THE PRINTER UNDER TEST, THE TITLE PRINT ROUTINE IS OMITTED.

DATE	3/17/69	4-23-63	25.6.63				
ENG. CHG. NO.	116745	117487	71-1844A				

REPRODUCTION

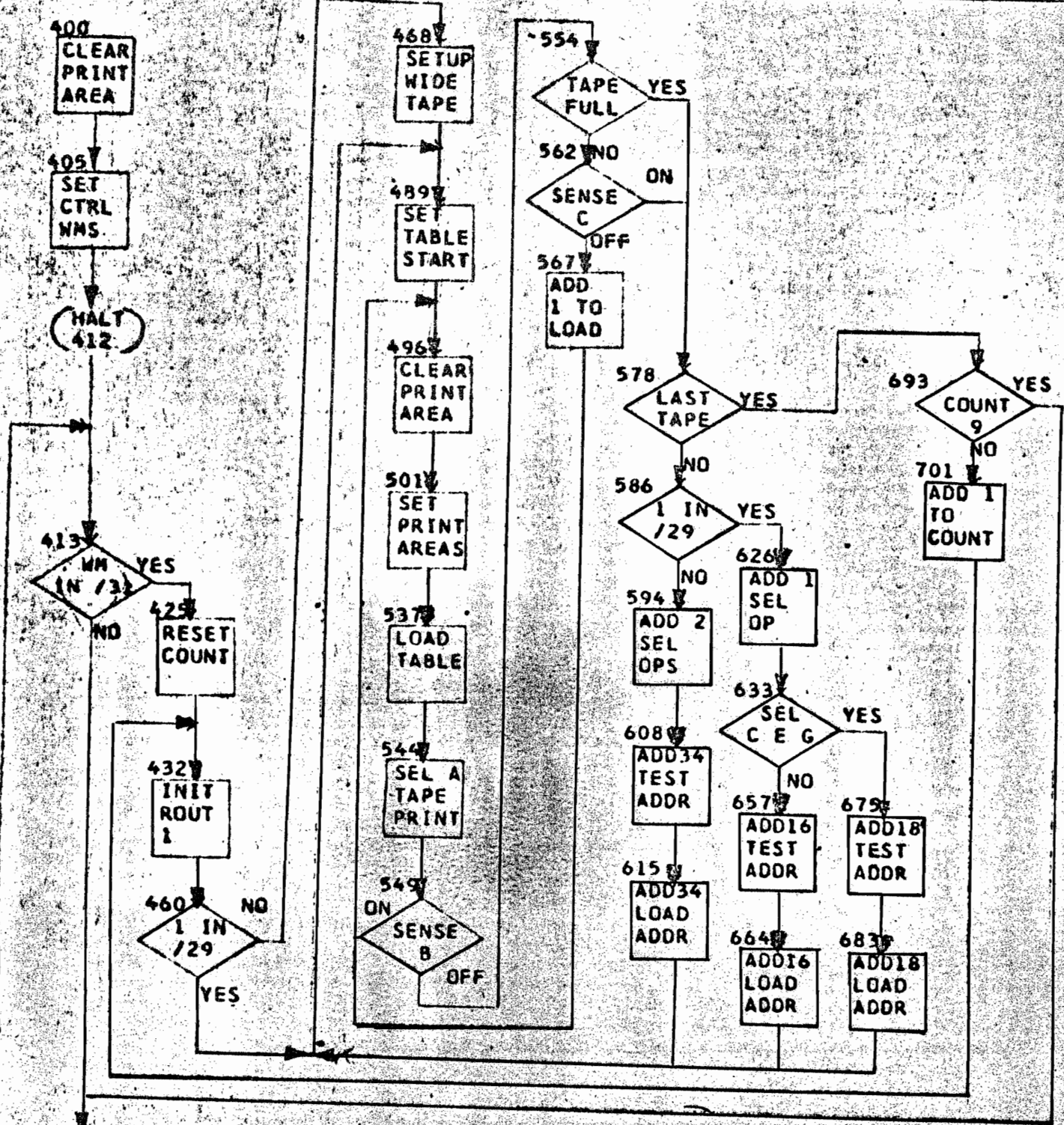

DATE	3/17/63	4-23-63	25.6.63				
ENG. CHG. NO.	118745	117487	TA-1844A				

DIAGNOSTIC FUNCTION TEST REPRODUCTION

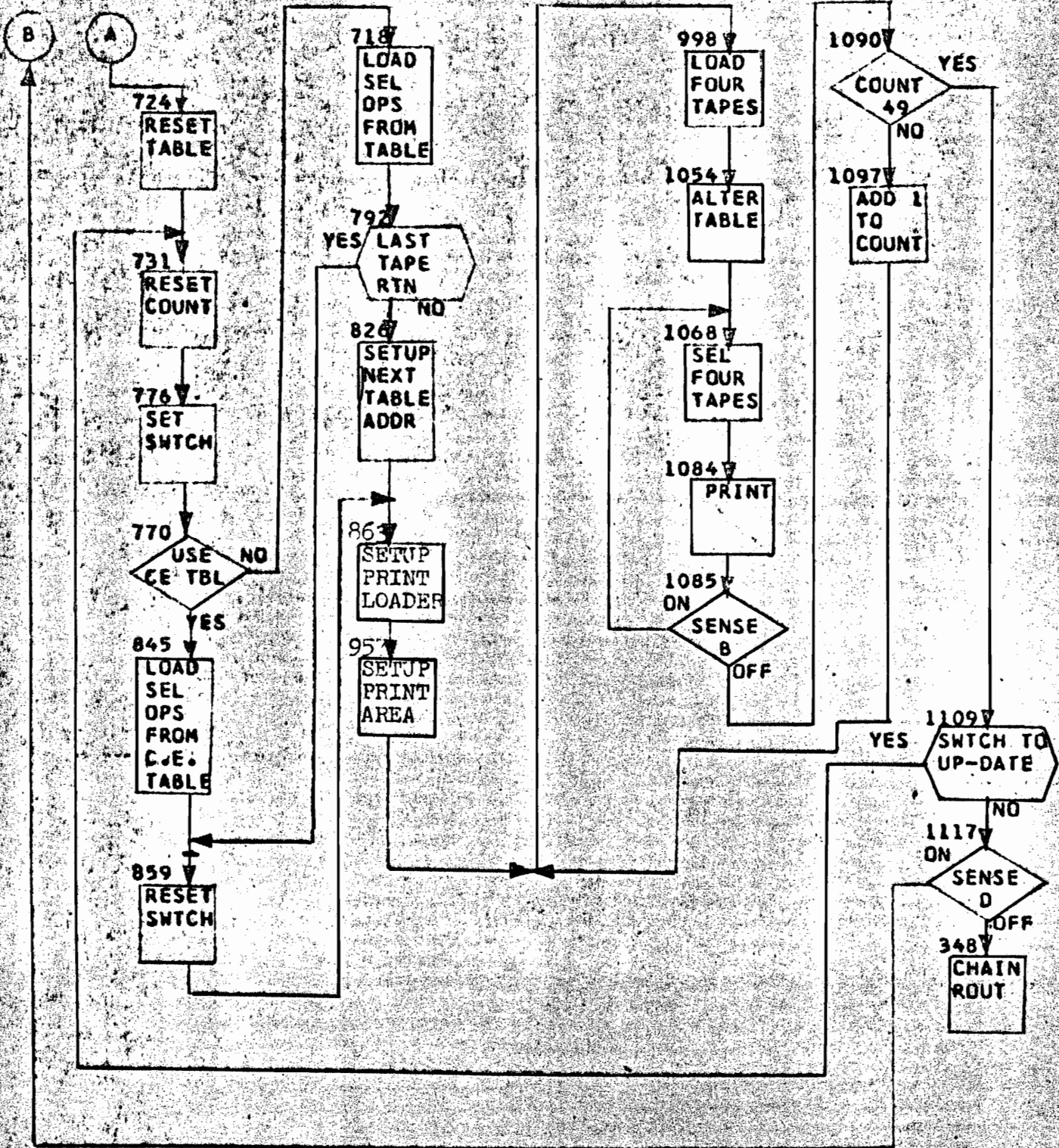

DATE	3/17/63	4-23-63	25.6.63				
ENG. CHG. NO.	116745	117487	TA-1844A				

PROGRAM LISTING FOR USE WITH FLOW CHART

MULTI TAPE LISTER A

1025A

REPRODUCTION

INSTRUCTION ADDRESS	OP	A	B	REMARKS
082	082			TABLES
102	102			..
110	110	1	111 1111111111	..
125	125	1	111 1111111111	..
139	139			..
140	140	1	234 5678 90- .5*0	..
160	160	0	*8. -09 8765 4321	..
180	180	2	468 0,80 1357 9-..	..
377	377	0	389 5614	USE WHEN RUNNING FROM MAG. TAPE
385	385	0	588	..
400	400	/	332	CLEAR PRINT AREA
404	404	/		..
405	405	.	/31 /32	SET CONTROL WMS IN
412	412	.		HALT
413	413	V	425 /311	TEST FOR 1ST WM
421	421	B	712	BR TO ROUTINE 2
425	425	M	/35 /28	RESET COUNTER
432	432	M	/61 545	INITIALIZE ROUTINE 1
439	439	M	/51 543	..
446	446	M	/59 547	..
453	453	M	/54 560	..
460	460	B	489 /291	BRANCH IF 1 IN ADWT
468	468	M	547 545	SETUP FOR WIDE TAPE
475	475	A	/36 547	..
482	482	A	/40 543	..
489	489	M	/57 540	RESET LOADER A FIELD
496	496	/	332	CLEAR PRINT AREA
500	500	/		..
501	501	B	523 /292	BR IF WIDE TAPE
509	509	.	217 251	SET TAPE PRINT AREAS
516	516	.	285 319	..
523	523	.	201 235	..
530	530	.	269 303	..
537	537	M	573 213	LOAD PRINT AREA LOADER
544	544	N	0	WIDE TAPE SELECT
546	546	F	A	TAPE SELECT
548	548	2		PRINT
549	549	B	544 B	BR IF SENSE SW B ON
554	554	B	578 2011	BR IF ALL 15'
562	562	B	578 C	BR IF SENSE SW C ON
567	567	A	/36 540	SHIFT IN ANOTHER 1
574	574	B	496	BR BACK

DATE	3/17/63	4-23-63	25.6.63				
ENG. CHG. NO.	118745	117487	TA-1844A				

