

Customer Engineering

1401 Pocket Reference Manual

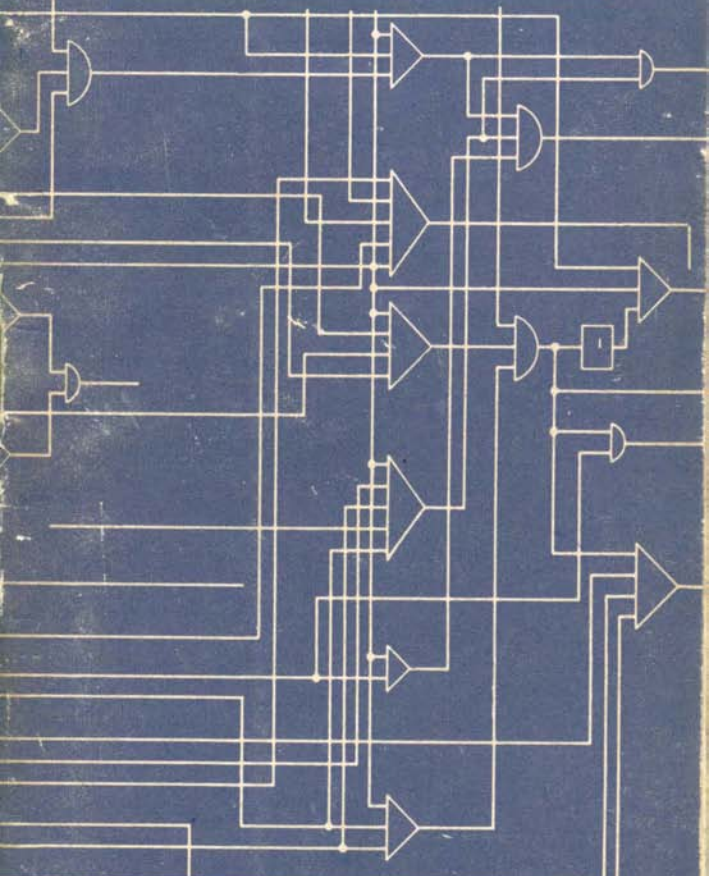

IBM Data Processing Division

IBM Form 56 389

Customer Engineering
1401 Pocket Reference Manual

ISSUED TO _____
BRANCH OFFICE _____
ADDRESS _____

IF THIS MANUAL IS MISLAID, PLEASE RETURN
TO ABOVE ADDRESS

IBM Data Processing Division

REPRINTED AND SUPPLEMENTED BY
IBM GERMANY PLANT CE DEPT. 901

CONTENTS

CODES _____	3
1401 BCD Code _____	3
Address Codes _____	3
Arith Zone Bits _____	3
Qui-Binary Code _____	3
C-Bit Generator _____	3
Machine Feature Index Codes for ALD's _____	4
Operation Codes _____	5
d MODIFIERS _____	6
d Characters for Branch _____	6
d Characters for Branch if Wordmark or Zone _____	7
d Characters for Form Control _____	7
DIAGNOSTIC FUNCTION TEST SET-UP _____	8
Sense Switch Control _____	8
Setup Digits _____	8
Tape Selection Digits _____	9
STOP CONDITIONS _____	10
All Stops _____	10
System Stop with Process Error _____	10
SMS INFORMATION _____	11
The Conducting Transistor always controls the Line _____	11
Component Testing _____	12
CORE-COMPOSITE _____	13
ALD DESIGNATION BY LOGIC FLOW _____	14
ALD DESIGNATION BY GATE LOCATION _____	15
I/O INSTRUCTION FORMAT _____	16
OPERATION OBJECTIVES _____	17
1 Read _____	17
2 Print _____	17
3 Print-Read _____	18
4 Punch _____	18
5 Read-Punch _____	18
6 Print-Punch _____	18
7 Print-Read-Punch _____	19
8 Read-Release _____	19
9 Punch Release _____	19

A Add	19
B Branch	20
C Compare	20
D Move Digit	20
E Edit	21
F Form Control	21
H Store B Star (optional)	21
K Stacker Select	21
L Load	22
M Move	22
N No Operation	22
P Move Record (optional)	22
Q Store A Star (optional)	22
S Subtract	22
U Unit Control	23
V Branch - Wordmark and/or Zone	23
W Branch if Bit Equal (optional)	23
X Expand compressed Tape (optional)	23
Y Move Zone	23
Z Move Zero Suppress	23
. Stop	24
<input type="checkbox"/> Clear Wordmark	24
/ Clear Storage	24
, Set Wordmark	24
% Divide (optional)	24
# Modify Address (optional)	25
@ Multiply (optional)	25
? Zero and Add	25
! Zero and Subtract	26
Indexing (optional)	26
PREVENTIVE MAINTENANCE 1401 SYSTEM	27
Introduction	27
1401/1406 PM Routine	28
1402 PM Routine	29
1403/1404 PM Routine	33
1405 PM Routine	35
1407 PM Routine	37
729 PM Routine	38
7330 PM Routine	41
TYPE ARRANGEMENT IDENTIFICATION	44
FIELD REPLACEMENT CARDS	57
COMPONENT CIRCUITS REFERENCE	58

A B } is Address 11000
 2 2 }
 CODES

1401 BCD CODE

Digit	Zone			
	NO	A	B	AB
NO	b	c	-	&
1	1	/	J	A
2	2	S	K	B
21	3	T	L	C
4	4	U	M	D
4 1	5	V	N	E
42	6	W	O	F
421	7	X	P	G
8	8	Y	Q	H
8 1	9	Z	R	I
8 2	0	+	!	? Q
8 21	#	,	\$.
84	@	%	*	□
84 1	:	=)	(
842	>	'	;	<
8421	✓	"	△	≠

ADDRESS CODES

Position	Bits	Value
HUNDREDS	A	1K
	B	2K
	AB	3K
UNITS	A	4K
	B	.8K
	AB	12K
TENS	Tag Bits	Index Reg
	A	87-89
	B	92-94
	AB	97-99

ARITH ZONE BITS

Bits	Sign (Units)	Overflow (High Order)
NONE	+	0, 4
A	+	1, 5
B	-(STD)	2, 6
AB	+(STD)	3, etc.

QUI-BINARY CODE

Digit	QUI	BI
0	Q0	B0
1	Q0	B1
2	Q2	B0
3	Q2	B1
4	Q4	B0
5	Q4	B1
6	Q6	B0
7	Q6	B1
8	Q8	B0
9	Q8	B1

C-BIT GENERATOR

Digit Bits	Parity of			Total Bits	Cd	WM	Cz	Generate C-bit
	WM Bits	Zone Bits	Zone Bits					
Odd	Odd	Even	Even	Cd	WM	Cz	Yes	
Even	Even	Even	Even	Cd	WM	Cz	Yes	
Even	Odd	Odd	Even	Cd	WM	Cz	Yes	
Odd	Even	Odd	Even	Cd	WM	Cz	Yes	

MACHINE FEATURE INDEX CODES FOR ALD'S

MFI	FEATURE	MFI	FEATURE
APF	Advanced Program	M8	800 BPI Density
BA	Basic	MD	Multiply Divide
BSR	1210 Bank Sorter Reader	MR	Move Record
BSR	Data Transmission	NNU	No Num. Print Control
BT	Bit Test	NPF	No Print Storage
CH	Column Binary	NU	Num. Print Control
CF	Card Feed — 1404	OV	Overlap
CFC	Card Feed Comp.	OVR	Overlap — R/P
CM	Attachm.s. Circuitry	OVRP	Overlap — PFR
CW	Compressed Tape	OVT	Overlap — Tape
DH	Dual Hopper	PF	Print Storage
DR	Drums	PT	Paper Tape Adapter
DS	Dual Speed Carriage	RAM	Disc Storage
EE	Expanded Print Edit	RP	Punch Feed Read
FP	Read Punch Release	SS	Sense Switches
HL	Hi-Lo-Equal Compare	1K	1.4 K Storage Only
IN	Indexing	2K	2 K Storage Only
INQ	Inquiry Station	4K	4 K Storage Only
IO	Input/Output	8K	8 K Storage Only
IOA	Input/Output	12K	12 K Storage Only
IOC	Input/Output Com.	1M	1.4 K Stor. & Above
LST	Low speed Tape	2M	2 K Storage & Above
M0	Any Tape Drive	4M	4 K Storage & Above
M2	729 II or V	8M	8 K Storage & Above
M3	7330	12M	12 K. Stor. & Above
M4	729 IV or VI	16M	16 K Storage
M6	729 II/V or IV/VI	100	100 Print Positions
		132	Add. Print Control

OPERATION CODES

1	Read
2	Print
3	Print-Read
4	Punch
5	Read-Punch
6	Print-Punch
7	Print-Read-Punch
8	Read Release
9	Punch Release
A	Add
B	Branch
C	Compare
D	Move Digit
E	Edit
F	Form Control
H	Store B Star
K	Stacker Select
L	Load
M	Move
N	No Op
P	Move Record
Q	Store A Star
S	Subtract
U	Unit Control
V	Branch — WM or Zone
W	Branch — Bit Equal
X	Move — Insert Zeros
Y	Move Zone
Z	Move Zero Suppress
.	Stop
□	Clear Wordmark
/	Clear Storage
,	Set Wordmark
%	Divide
#	Modify Address
@	Multiply
?	Zero and Add
!	Zero and Subtract

d MODIFIERS

d CHARACTERS FOR BRANCH

BIId

d-Character	Branch On
h	Unconditional
9	Carriage Channel #9
@	Carriage Channel #12
A	"Last Card" Switch (Sense Switch A)
B	Sense Switch B*
C	Sense Switch C*
D	Sense Switch D*
E	Sense Switch E*
F	Sense Switch F*
G	Sense Switch G*
K	End of Reel * **
L	Tape Transmission Error*
N	Access Inoperable*
?	Reader Error if I/O Check Stop Switch is off**
!	Punch Error if I/O Check Stop Switch is off**
P	Printer Busy (print storage feature)*
+	Print Error if I/O Check Stop Switch is off**
/	Unequal Compare (B ≠ A)
*	Inquiry Clear*
Q	Inquiry Request*
R	Printer Carriage Busy (print storage feature)*
S	Equal Compare (B = A)*
T	Low Compare (B < A)*
U	High Compare (B > A)*
V	Read-Write Parity Check or Read-Back Check Error*
W	Wrong-Length Record*
X	Unequal-Address Compare*
Y	Any Disk-Unit Error Condition*
Z	Overflow**
%	Processing Check with Process Check Switch off**

*Special feature.

**Conditions tested are reset by a BRANCH IF INDICATOR ON instruction.

d CHARACTERS FOR BRANCH IF WORDMARK OR ZONE

VIIIIBBd

d-Character	Condition
1	Wordmark
2	No zone (No-A, No-B-bit)
B	12-zone (AB-bits)
K	11-zone (B, No-A-bit)
S	Zero-zone (A, No-B-bit)
3	Either a wordmark, or no zone
C	Either a wordmark, or 12-zone
L	Either a wordmark, or 11-zone
T	Either a wordmark, or zero-zone

d CHARACTERS FOR FORM CONTROL

Fd

d	Immediate skip to	d	Skip after print to
1	Channel 1	A	Channel 1
2	Channel 2	B	Channel 2
3	Channel 3	C	Channel 3
4	Channel 4	D	Channel 4
5	Channel 5	E	Channel 5
6	Channel 6	F	Channel 6
7	Channel 7	G	Channel 7
8	Channel 8	H	Channel 8
9	Channel 9	I	Channel 9
0	Channel 10	?	Channel 10
#	Channel 11	.	Channel 11
@	Channel 12	□	Channel 12

d	Immediate space	d	After print-space
J	1 space	/	1 space
K	2 spaces	S	2 spaces
L	3 spaces	T	3 spaces

DIAGNOSTIC FUNCTION TEST SET-UP

SENSE SWITCH CONTROL

B on Tight loop
 C on Print Correct
 D on 1 card loop
 E on Error stop
 *F on Perform
 *F off Bypass
 **F on PAR Mode
 G on Adv Prog

SETUP DIGITS

Storage Location	Char	Control
**1251	1	2K
	2	12K
	4	4K
	6	16K
	8	8K
1252	1	Print Titles
**1298	1	Overlap
**1299	1	Reader
	4	Punch
	M	Tape
	R	Paper Tape Reader
	W	Paper Tape Punch
	2	1412
	9	1419

*Applies to old style DFT's (0060, etc.) only.

**Applies to new style DFT's (1C01, etc.) only.

TAPE SELECTION DIGITS

Storage Location	Digit	Run DFT
1254	1	Copy Test Tape
*1255	1	Sense Switches
**1255	1	Carriage
1256	1	Col Binary
1257	1	Indexing
1258	1	Mult/Div
1259	1	Hi-Lo-Eq
1261	1	Print
*1261	1	Carriage
**1261	3	Num. Print
*1262	1	Ripple Punch
*1263	1	Ripple Read (Detail Cards needed)
1264	1	Modify Address
*1265	1	Core Worst 1.4K
	2	2K
	4	4K
	8	8K
	-	12K
	&	16K
**1265	1	Core Worst
*1268	4	Tape
*1268	1	Tape VRC
**1268	1	Tape
1269	1	IRG
1270	1	Comp Tape
1271	1	Branch on Error
1272	1	PFR
1273-4	B1#	Perform/Bypass Block *(Enter 4 in 1329 & 1332)
1273-6	DFT#	Perform/Bypass DFT
**1277	1	Run DFT only
	2	Bypass DFT
	3	Run Block only
	4	Bypass Block
**1278	1	Stacker Select
**1279	1	Read Release

*Applies to old style DFT's (0060, etc.) only.

**Applies to new style DFT's (1C01, etc.) only.

STOP CONDITIONS

ALL STOPS

- A. The Address Register light indicates the cycle just completed.
- B. The Storage Address Register contains the address of the cycle just completed.
- C. If in I cycles, the Instruction Length indicates the I cycle just completed.

SYSTEM STOP WITH PROCESS ERROR

- A. A Register light
 1. A Register out of parity
 2. stops at the end of the next cycle
- B. B Register light
 1. B Register out of parity
 2. stops at the end of the same cycle
- C. Logic Unit light
 1. Adder output validity
 2. stops at the end of the next cycle
- D. Op Register light
 1. Op Register parity or validity
 2. not checked during I op
- E. Storage Address Register light
 1. parity or validity check of the serial lines
 2. stops at the end of the cycle that storage is addressed, for an error in the units or tens position
 3. stops at the end of the next cycle after storage is addressed, for an error in the hundreds position (also includes wrap around condition)

SMS INFORMATION

THE CONDUCTING TRANSISTOR ALWAYS CONTROLS THE LINE

BASE VOLTAGE WITH UNIT CONDUCTING				COLLECTOR LOADS BY CAP CODES				
Family	Inputs	Base	Level	Cap Code	Circuits			
					01	02	03	04
CEE	CDEL	L	+U	VA	Yes	No	No	No
	BNPQ	B	+U	VB	Yes	Yes	Yes	Yes
	FGHK	H	+U	VN	Yes	Yes	No	No
CG	BC	TP9	+U	VP	Yes	Yes	Yes	Yes
	FG	TP8	+U	VU	Yes	No		
	DE	TP2	+U	VV	Yes	No	No	
CH	BC	TP9	-T	VW	Yes	Yes	No	
	FG	TP8	-T	WF	No	No		
	DE	TP2	-T	WV	Yes	Yes		
CJ	DEFG	G	+U	WW	Yes	Yes	Yes	
	ABC	TP3	+U	YC	Yes	Yes		
				YG	Yes	No	No	No
CK	DEFG	G	-T	ZT	Yes	Yes	No	No
	ABC	TP3	-T	ZV	Yes	Yes	Yes	Yes
				2JMX	Yes	Yes		
CQ	EN	N	+U	3JMX	No	No		
	BF	B	+U	4JMX	Yes	Yes		
CR	EN	N	-T					
	BF	B	-T					
CY	ABC	A	+U	J	Ground			
	DEP	P	+U	K	Minus	6		
JG	BC	TP9	+U	L	Plus	6		
	FG	TP8	+U	M	Minus	12		
	DE	TP2	+U	N	Plus	30 (Special)		
JH	DEFG	G	+U	Q	Plus	6M		
	ABC	TP3	+U	R	Minus	12M		

VOLTAGE PINS

COMPONENT TESTING

Most defective components can be located by using an ohmmeter to check for an open or shorted condition. Be sure to consider parallel components when testing with an ohmmeter. An excellent method of determining the correct readings is to compare the readings of an identical, good card with those of the defective card.

The transistor is considered as a back-to-back diode. Check the forward and reverse resistance of each diode with an ohmmeter adjusted to X100 ohm scale. The forward-to-reverse resistance ratio should be 10. Emitter-to-collector resistance should be the same as the reverse resistance.

Test diodes with an ohmmeter in the same way transistors are tested.

MINIMUM INPUT VOLTAGES TO CONTROL TRANSISTORS

C, V and Z lines undefined

AND's and OR's

Plus N	0.4	Minus N	-0.4
Plus P	-5.6	Minus P	-6.4
Plus R	5.6	Minus R	0.2
Plus S	-0.2	Minus S	-5.6
Plus T	1.4	Minus T	-0.7
Plus U	-5.3	Minus U	-7.4
Plus Y	-0.6	Minus Y	-5.8

CW and JZ Triggers

Plus T	1.4	Minus T	-0.7
Plus U	-0.5	Minus U	-7.4

AR and AS Triggers

Plus S	-0.2	Minus S	-5.6
Set pulse 2.6 volt shift			

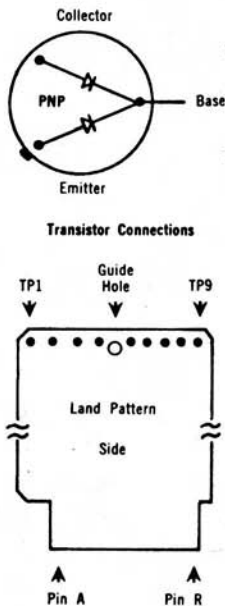

CORE-COMPOSITE

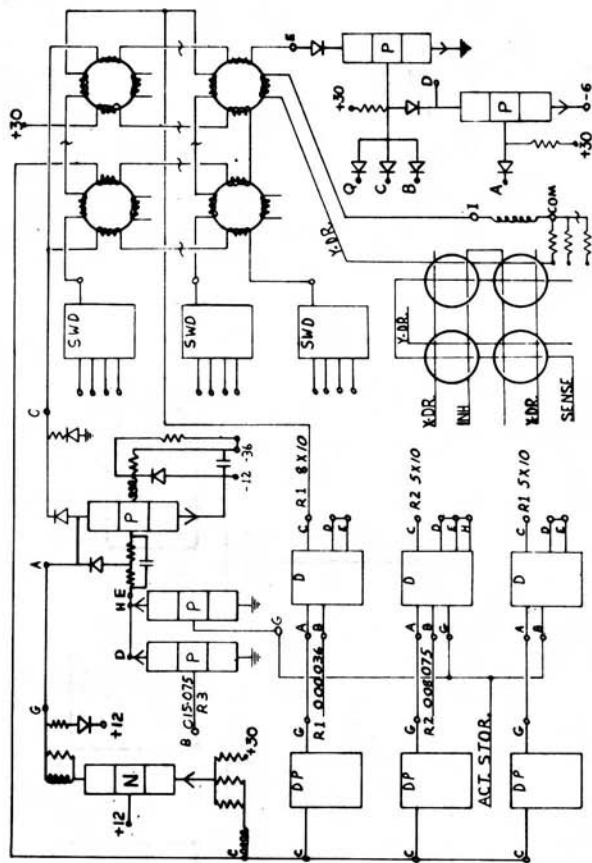

ALD DESIGNATION BY LOGIC FLOW

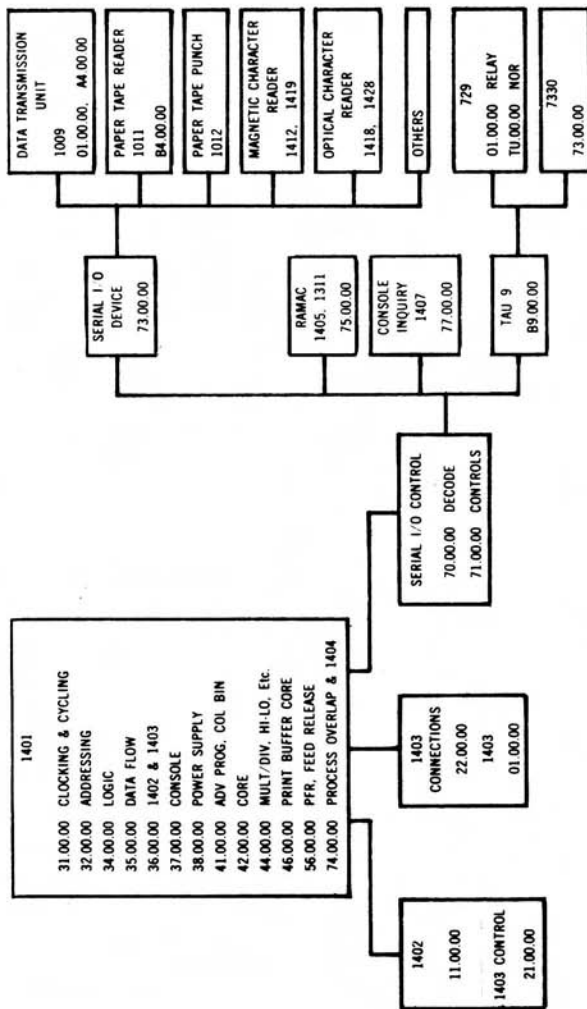

ALD DESIGNATION BY GATE LOCATION

01A1 CORE 42.00.00	01A2 CONSOLE 37.00.00	01A3 DATA FLOW 35.00.00	01A4 PR BUFFER 46.00.00	02A1 I/O CONTR 71.00.00 TAU CONTR 89.00.00	02A2 I/O DECODE 70.00.00 SER I/O 73.00.00	02A3 POWER SUPP 38.00.00	02A4 POWER SUPP 38.00.00
01B1 OP REG 35.00.00 CARRIAGE 36.00.00 OPTIONS 41-56	01B2 CLOCKING & CYCLING 31.00.00	01B3 TIME 31.00.00 LOGIC 34.00.00	01B4 READ PUNCH 36.00.00	02B1 OVERLAP 74.00.00	02B2 TAU (008A) 89.00.00	02B3 TAU (008B) 89.00.00	02B4 TAU (008C) 89.00.00
01A5 CARRIAGE 46.00.00	01A6 PRINT 36.00.00	01A7 ADDRESSING 32.00.00	01A8 ADDRESSING ADR DECODE 42.00.00	02A5 POWER SUPP 38.00.00	02A6 POWER SUPP 38.00.00	02A7 MULT DIV 44.00.00	02A8 MULT DIV 44.00.00
01B5 HAM'S DR 36.00.00	01B6 I RING 31.00.00 LOGIC 34.00.00 A & B REG 35.00.00	01B7 RD PCH CHK 36.00.00 PFR 56.00.00	01B8 CABLES	02B5 CABLES	02B6 ADV PROG 41.00.00 COMP WORD 44.00.00	02B7 MULT DIV 44.00.00	02B8 MULT DIV 74.60.00

I/O INSTRUCTION FORMAT

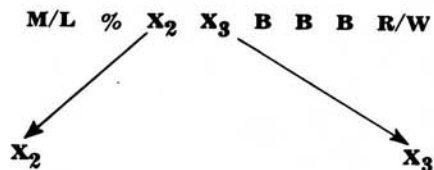

Char	Function	Char	Function
U	Even Parity Tape	1-6	Tape Unit 1-6
B	Odd Parity Tape		
C	Compressed Tape		
D	1009 - Tele-Processing®	1	
P	1011 - Paper Tape Reader	1	
S	1412 - Sorter Reader	1	
T	1407 - Console Inquiry	0	
F	1405 - RAMAC®	0	Seek
		1	Single Record
		2	Full Track
		3	Write Check
		4	Write Address

Data field format for RAMAC®

BBB Address

A M D D T T R O ≡ (Data Record →) ≡

OPERATION OBJECTIVES

1 READ

- A. Energize the Read clutch
- B. Read card 9 edge first
 1. row by row (9, 8, 7, etc.)
 2. store in 80 row bit cores
- C. Keep track of digit time in A Reg
 1. complement Add A Reg C-bit
 2. position 000 to store digit time
 3. 3 B cycles at 9 time (one cycle to clear 000)
 4. 2 B cycles 8-12 time
- D. Scan out row bit cores into 001-080 of storage
 1. between reading rows
 2. 80 B cycles
 3. inhibit A Reg if hole read
 4. combine with previous hole read in same column
- E. I/E change after 12 time
 1. all scans complete

2 PRINT (with print storage)

- A. Transfer
 1. transfer 1401 storage positions 201-332 to print storage positions 001-132
 2. I/E change
 - a. print transfer end
- B. Print
 1. option each hammer 48 times
 - a. once for each possible character
 2. 49 print scans
 - a. 48 to option hammers
 - b. 1 for error checking
 - c. each print scan contains 3 sub scans
 3. 144 sub scans to option hammers
 - a. each sub scan options 1/3 of the hammers
 - b. sub scan one starts with hammer one and options every 3rd hammer

- c. sub scan two starts with hammer two and options every 3rd hammer
- d. sub scan three starts with hammer three and options every 3rd hammer
- 4. print scan end on 49th scan
 - a. print scan 49
 - b. print storage address 132
- 5. automatic single space after print

3 PRINT-READ

- A. Print is executed first
- B. Read clutch energized after print scan 40

4 PUNCH

- A. Energize the punch clutch
- B. Keep track of digit time in A Reg
 - 1. 3 B cycles at 12 time (one cycle to clear 100)
 - 2. 2 B cycles 11-9 time
 - 3. force adder carry and B bit to A Reg for zone time only
 - 4. position 100 to store digit time
- C. Scan out storage positions 101-180 each digit time
 - 1. 80 B cycles
 - 2. fire punch magnets if punch decode
 - 3. 13 punch scans—12 for punching & 1 to finalize checking
- D. I/E change
 - 1. after 9 time
 - 2. last address (180)

5 READ-PUNCH

- A. Read and punch simultaneously
- B. The first one calling for a scan causes the other to wait until scan completed

6 PRINT-PUNCH

- A. Print is executed first
- B. Punch clutch energized after print scan 32

7 PRINT-READ-PUNCH

- A. Print is executed first
- B. Punch clutch energized after print scan 32
- C. Read clutch energized after print scan 40
 - 1. punch and read operations are executed simultaneously
 - 2. the first one calling for a scan causes the other to wait until scan completed

8 READ-RELEASE

- A. Immediate read clutch energization
- B. Release the 1401 for processing
- C. Read op must occur before 9 time (20 ms)

9 PUNCH RELEASE

- A. Immediate punch clutch energization
- B. Release the 1401 for processing
- C. Punch op must occur before 12 time (35 ms)

A ADD

- A. Analyze sign
 - 1. one A and B cycle
 - a. no modification
 - b. no adding
 - 2. analyze A & B Reg signs
 - a. determine if true or complement
 - b. if complement make B field sign standard
- B. True add
 - 1. 2nd B cycle (first add cycle)
 - a. transfer B Reg zone (sign)
 - 2. add A and B Registers (digits)
 - 3. B cycle — B Reg wm
 - a. add zones for overflow
 - b. I/E change
- C. Complement add
 - 1. 2nd B cycle (first add cycle)
 - a. transfer B Reg zone (standard sign)
 - b. force a carry for units position
 - 2. complement Add A Reg to B Reg plus carry (digits)

3. B cycle — B Reg wm
 - a. no carry - recomplement
 - b. carry - I/E change

D. Recomplement

1. reverse scan
 - a. eliminate A cycles
 - b. modify plus one
 - c. scan for B-bit in B Reg (units position-sign)
2. 2nd forward scan
 - a. readdress each position reading into A Reg on the first cycle and force 82 C to storage
 - b. on second cycle read out the 82 C and complement add the A Reg
3. I/E change
 - a. B Reg wm

B BRANCH

A. B III

1. read out A star for next instruction unconditionally

B. B III d

1. read out A star for next instruction if d character condition met

C. B III BBB d

1. read out A star for next instruction if B character at B address is the same as the d character

C COMPARE

A. The A and B fields are compared bit by bit

1. B equal A (optional)
2. B unequal A (standard)
3. B greater than A (optional)
4. B less than A (optional)

B. If B field longer than A field, causes unequal and B greater than A, regardless of data

D MOVE DIGIT

- A. One A and B cycle (one character I/E change)

B. Move the digit of A field to B field

C. Retain B field zone

E EDIT

- A. Control word must be loaded into B field prior to Edit op
- B. Merge A field into B field control word in place of zeros and blanks
- C. Cycling under control of control word

F FORM CONTROL

- A. Four types of program operations
 1. space before print (immediate space)
 - a. d character includes B-bit only
 2. space after print
 - a. d character includes A-bit only
 3. skip before print (immediate skip)
 - a. d character includes no zones
 4. skip after print
 - a. d character includes A-bit and B-bit

H STORE B STAR (Optional)

- A. Stores B star address into A field
 1. 3 A cycles (no B cycles)
 2. read B star address into A Reg and inhibit to storage

K STACKER SELECT

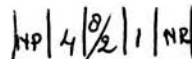

A. Read

1. card just read, selects according to d character
2. must be given within 10 ms after read operation completed

B. Punch

1. card just punched selects according to d character
2. must be given prior to next punch instruction
3. punch error will override and card will feed into NP pocket

L LOAD

- A. Transfer entire A field into the B field including the wordmark
- B. B field wordmarks are ignored
- C. I/E change with A field wordmark

M MOVE

- A. Transfer the A field characters to the B field excluding the wordmark
- B. Wordmarks are retained in their respective fields
- C. I/E change with either A or B field wordmark

N NO OPERATION

- A. Activate execute eliminate
- B. Used to step over an area of storage and to retain continuity of the program

P MOVE RECORD (Optional)

- A. Similar to a move operation except a wordmark does not end operation
- B. Reverse scanned — modify plus one
- C. I/E change with A field record-mark or group-mark wordmark

Q STORE A STAR (Optional)

- A. One dummy cycle between Iop and Il to transfer the A star to the B star
- B. Stores B star address into A field
 1. 3 A cycles (no B cycles)
 2. read B star address into A Reg and inhibit to storage

S SUBTRACT

- A. Same as add

U UNIT CONTROL

- A. The A address selects a particular unit which will perform the function denoted by the d character
- B. This instruction used with tape and serial I/O

V BRANCH — WORDMARK AND/OR ZONE

- A. Read out A star for next instruction if B field character meets the d character requirement

W BRANCH IF BIT EQUAL (Optional)

- A. Read out A star for next instruction if B field character contains any bit that the d character contains

X EXPAND COMPRESSED TAPE (Optional)

- A. Similar to a move operation in data transfer
- B. Zeros are inserted in numerical fields under control of the mode change and sign of numerical field
- C. I/E change with group-mark wordmark

Y MOVE ZONE

- A. One A and B cycle (one character I/E change)
- B. Move the zone of A field to B field
- C. Retain B field digit

Z MOVE ZERO SUPPRESS

- A. Forward scan
 1. same as a move operation except:
 - a. a wordmark is forced in units position
 - b. B field wordmarks are ignored
 - c. A field wordmark causes a reverse scan
- B. Reverse scan
 1. eliminate all wordmarks
 2. eliminate zeros to the left of first numeric digit
 3. I/E change with wordmark in units position

STOP

- A. Cause delta process to reset at the end of I phase
- B. Turn on indicator in stop switch

□ CLEAR WORDMARK

- A. One A and B cycle (one character I/E change)
- B. Remove wordmark from A and B addresses
- C. Retain data characters

/ CLEAR STORAGE

- A. Eliminate A cycles
- B. Inhibit C-bits only to storage
- C. I/E change with a borrow from hundreds position during modify

SET WORDMARK

- A. One A and B cycle (one character I/E change)
- B. Force a wordmark in A and B addresses
- C. Retain data characters

% DIVIDE (Optional)

- A. Function
 1. divide the dividend (low order of B field) by the divisor (A field) and develop the quotient in the high order of the B field
 - a. the dividend is reduced by once or twice the divisor
 - b. division starts with the high order position of the dividend
 - c. remainder is left in the low order of the B field
- B. Rules
 1. the length of the B field is equal to the number of digits in the divisor and dividend plus one
 2. the A field must be defined with a wordmark
 3. the dividend must have standard sign and zeros must be in high order of B field

4. the units of the quotient is the address of the units of the dividend, minus length of divisor minus one

MODIFY ADDRESS (Optional)

- A. Gives the ability to add two addresses
- B. Requires 3 A cycles and 3 or 5 B cycles
 1. first cycle adds digits and zones. Any zone carry is lost but a digit carry is taken forward
 2. second cycle adds digits only and takes any carry forward
 3. third cycle adds digits and zones. Any digit carry is added to zone portion and any zone carry is added to units zone
 4. fifth cycle (if zone carry) adds carry to units position. Any carry is lost
- C. No wordmarks are required

@ MULTIPLY (Optional)

- A. Function
 1. the multiplicand (A field) is repetitively added to the B field under control of the multiplier (high order of B field)
 - a. the multiplier is reduced each time an addition takes place until it is reduced to zero
- B. Rules
 1. the length of the B field is equal to the number of digits in the multiplicand and multiplier, plus one
 2. both fields must be defined with wordmarks

? ZERO AND ADD

- A. The A field is transferred to the B field
- B. A standard sign is generated (algebraic sign control)
- C. The high order positions are filled with zeros
- D. B field data is cleared
- E. I/E change with B field wordmark

! ZERO AND SUBTRACT

- A. Same as zero and add

INDEXING (Optional)

- A. No Op Code (Auto I Phase function)
- B. Index register is added to A or B star
 - 1. zone bits in address tens selects index reg
 - a. A or B star gates to A reg
 - b. index reg (storage) gates to B reg
 - c. adder gated to A or B star
 - 2. 3 or 4 cycles taken after I_3 or I_6
 - a. 4th cycle if hundreds zone carry

PREVENTIVE MAINTENANCE 1401 SYSTEM

INTRODUCTION

The objective of scheduled maintenance is to make the most possible machine time available to the customer. All scheduled maintenance should be directed toward this objective. Scheduled maintenance includes only procedures necessary for continuous, satisfactory machine operation and procedures designed to reveal potential troubles. Do not disassemble or adjust satisfactorily operating units; this consumes time and gains nothing - it may even cause trouble. When performing scheduled maintenance, always check with the customer about machine performance. His comments may help spot intermittent or potential troubles.

The first step in scheduled maintenance is visual inspection. Look for corrosion, loose wires and pins, burned contact points, need for lubrication, badly worn parts, loose screws and dirt. Many potential troubles are spotted visually and corrective action can be taken before machine failure.

The PM routines for the 1401 system, including 1401, 1402, 1403, 1404, 1405, 1406, 1407, 729 and 7330, have been standardized and updated. The frequency shown in weeks and hours is based upon 200 hours of operation per month. The routines should be understood as guides. The frequency should be modified in such a way that the customers workload on the different machines is being considered.

1401/1406 PM ROUTINE

UNIT	FREQUENCY	PROCEDURE	CLEAN AND LUBRICATE
Console	4 weeks 200 - 300 hrs.	Check <u>indicators</u> and switches	<i>adrs 3777 + 3886.</i>
US Blowers	4 weeks 200 - 300 hrs.	Check old style black muffin blowers of US origin	} -1 → +1 1/2 V.
SMS-Cards	24 weeks 1200 - 1800 hrs.	Run all diagnostic tests with +2V variation of the +6VM and -12VM. Use DC meter to assure that voltage is changing. Run worst pattern test 9100 to find upper and lower limit. For core storage variation see CEM 396. Record optimum setting.	
Power Supplies	24 weeks 1200 - 1800 hrs.	Measure all DC voltages in the gates as described in Reference Manual (Installation procedure) with a DC meter of 0, 5% accuracy (Weston 901 DC meter). Note change before readjusting. Measure ripple (2%).	
Blower and Filters	24 weeks 1200 - 1800 hrs.	Replace if dirt is visible from inside. Check blowers for proper operation.	Clean clogged blowers.
Relays	24 weeks 1200 - 1800 hrs.	Check contacts, adjustments and free travel of armature.	Clean contacts.

1402 PM ROUTINE

UNIT	FREQUENCY	PROCEDURE	CLEAN AND LUBRICATE
Punch Unit Old Style	8 weeks 400 - 600 hrs.	Check cam followers for wear and proper adjustments.	Felt wicks for punches with IBM No. 9. Four punch bail cam follower fittings with IBM No. 20. Felt wicks for latches with IBM No. 9. Latch spring hooks with IBM No. 17. Punch cam follower pivots, bearing links, die locating studs with IBM No. 20.
Geneva Asm.	8 weeks 400 - 600 hrs.	Check for excess internal backlash in the geneva mechanism on at least two subsequent motion cycles.	If necessary fill to 1/16" (1,6 mm) above line with IBM No. 9.
Read Feed	8 weeks 400 - 600 hrs.	Check brush wear and timing (use CE service panel). Check condition of belts and feed rolls.	Ball bearing and all other pivots with IBM No. 6. Clean card feed. Lubricate all gears, picker knife cams, spring ends with IBM No. 17.
File Feed	16 weeks 800 - 1200 hrs.	Check clutch overthrow, condition of belts and feed rolls.	Lubricate belt with Lubriplate 70. Cam follower arm, front and side joggler pivots with IBM No. 9. All other pivots with IBM No. 6. Front joggler spring ends, joggler cams, adjusting screw surfaces, clutch latch cam surface, side joggler flat return spring with IBM No. 17. Clutch grease fitting with IBM No. 20.

Stacker and Transport	16 weeks 800 - 1200 hrs.	Check for belt wear.	Clean transport, lubricate card pusher slide spring ends and cams with IBM No. 17. Stacker jogger clutch spring grease fittings with IBM No. 20. Lubricate timing belts with Lubriplate No. 70.
CB's	16 weeks 800 - 1200 hrs.	Check contact condition and movement. Check timing of CB's connected to CE service panel.	CB arm pivots and rollers with IBM No. 9. CB cam and drive gears (Non-Nylon cams only, Nylon cams are greased initially only) with IBM No. 17.
Punch Feed and Transport	16 weeks 800 - 1200 hrs.	Check punch registration, belt tension and condition. Check common brush on contact rolls. If variation is more than 1° - 2° , belts or pulleys may be worn. Check brushes for wear, damage and correct timing.	Clean card feed. Lubricate feed roll hanger pivots, card lever pivots, all clutch pivots with IBM No. 9. Gears, aligner, cams, punch clutch, latch cam, extension spring ends with IBM No. 17. Belts with Lubriplate No. 70, stacker jogger clutch spring with IBM No. 20.
Read Clutch	16 weeks 800 - 1200 hrs.	Check detent, pawls and keeper for wear. Excess clutch backlash while engaged. Check clutch drive pulley shock mount for looseness.	Armature, latch and keeper pivots, load detent pawl pivots, clutch intermediate arm pivot with IBM No. 9. Continuously running clutch drive wheel, clutch needle bearing, grease fitting, keeper and latch operating surfaces and reverse lock grease fitting with IBM No. 17.
Punch Unit Old Style	16 weeks 800 - 1200 hrs.	Check cam follower adjustments.	Remove felt wick at top of punch unit and lubricate six oil lines, latch wick and link pivots with

Punch Unit New Style	24 weeks 1200 - 1800 hrs.	Check cam follower adjustments. Check punch bail and set-up bail for excessive wink (should not exceed .010" in any direction when cam followers are held tight against cam).	IBM No. 9. Armature pivots and set up bail channel, latch spring hooks with IBM No. 17.
Punch Clutch	24 weeks 1200 - 1800 hrs.		Remove felt wick at top of punch unit and lubricate six oil lines, latch wick, link pivots with IBM No. 9. Stripper cavity latch spring hooks, armature pivots, set up bail channel, cam surfaces with IBM No. 17. Six punch unit grease fittings, die locating studs with IBM No. 20.
Filter	24 weeks 1200 - 1800 hrs.	Replace if dirt is visible from inside.	Latch, cam follower, all other clutch pivots and dog stud with IBM No. 9. Latch cam and armature at latch pivot with IBM No. 17.
Relays	24 weeks 1200 - 1800 hrs.	Check and clean contacts of HD3 and HD8 (see CEM 639 (SA 149) Safety).	
Motors	24 weeks 1200 - 1800 hrs.		Oil read and punch Motors with IBM No. 9.
Geneva Drive	48 weeks 1200 - 1800 hrs.		Change geneva oil using IBM No. 9.

1403/1404 PM ROUTINE

Before starting 1403 PM, check last customer job for print quality.

UNIT	FREQUENCY	PROCEDURE	CLEAN AND LUBRICATE
Drive Chain	4 weeks 200 - 300 hrs.	Check that reservoir never runs dry. Check that oil reaches the chain. Check for chain binds. If bind is detected perform off-cartridge cleaning.	Fill right oil reservoir in T-casting IBM No. 6. Clean type chain with vacuum cleaner as required. Clean type face with IBM cleaner P/N 451529. If chain is dry, atomize with IBM No. 6 before using the cleaner (see CEM 868).
Print Ribbon	12 weeks 600 - 900 hrs.	Check for wear, correct ribbon reverse and skew operation.	Toggle plate pivot IBM No. 6. Reverse toggle spring ends IBM No. 24. Skew roller pivot IBM No. 6. Wipe excessive oil and grease from all areas to prevent contaminating ribbon.
Drive Chain	12 weeks 600 - 900 hrs.		Light film grease No. 22: drive key, pinion, intermediate and drum gears. Relubricate bevel gear chain unit with IBM No. 22 grease (see CEM 775).
Ribbon Drive Unit	12 weeks 600 - 900 hrs.	Check for wear and binds. Check for correct operation.	All gears Lubriplate No. 70 (light film). All bearings, pivots and clutch shafts IBM No. 6. Friction disk interposer stud and ball IBM No. 6. Keep friction reverse-drag surfaces oil-free. Wipe ex-

Ribbon Drive Gear Reduction	12 weeks 600 - 900 hrs.	Gears and motors of German origin are lubricated for lifetime. Lubrication instructions apply to US parts only.	cessive oil and grease from all surfaces to prevent contamination of ribbon.
Ribbon Drive Motor	12 weeks 600 - 900 hrs.		Without oil level hole: 1/8 ounce IBM No. 6 to cup on top (may have screw instead of cup). With oil level hole: Fill with IBM No. 6 to oil level hole. Replace screw.
Brush Emitter	12 weeks 600 - 900 hrs.	Check for worn brushes. Check for pitted surface. See 1401 CEM 247 on use of Tacho Generator.	Bearing oil cups (2 oil cups) IBM No. 6 (8 drops each cup).
Forms Cart	12 weeks 600 - 900 hrs.	Check for proper grounding. Check grounding strips for foreign material.	Wipe all dirt from emitter surface.
Blowers Hammer Unit	24 weeks 1200 - 1800 hrs.		Replace blower air filter if dirt is visible from inside.
Feed Tractor	24 weeks 1200 - 1800 hrs.	Check tractor adjustments as required.	Light film Lubriplate No. 70 on tractor drive pulleys, tractor shafts and operating surface of tractor belt.
Stacker	24 weeks 1200 - 1800 hrs.	Check for broken friction springs. Check for wear on friction drive roll.	Light film Lubriplate No. 70 on bevel drive gears and drive belt. Use IBM No. 6 on friction drive shaft. Clean as necessary.

34 Print Hammer Unit	24 weeks 1200 - 1800 hrs.	Check for loose hammers and magnet coils, Check for worn armature pivots, Check for broken hammer springs.	Use IBM No. 6 on hammer magnet armature pivots. Use light film IBM No. 6 on armature backstops and hammer surfaces that contact armatures, Do not atomize. Clean armature backstops before applying IBM No. 6. Replace all hammer magnet residuals.
Print Chain	24 weeks 1200 - 1800 hrs.	Check for correct chain tension.	Perform off-cartridge chain cleaning only if necessary (as little as possible).
Motor Chain Drive	24 weeks 1200 - 1800 hrs.		Remove oil screw and apply oil No. 6 (to German motors only).
Drum	24 weeks 1200 - 1800 hrs.	Scope drum head output (ground to one side of read head). Should be 50 - 150 mv. Adjust head-to-drum clearance as necessary but do not go below .003".	
Contact Rolls	24 weeks 1200 - 1800 hrs.	Check tape brushes for loose strands.	Contact roll bearings IBM No. 6. Clean contact rolls.
Drive Hydraulic Unit	24 weeks 1200 - 1800 hrs.	Check timing belt tension, Check for correct hydraulic fluid level (appr. to bottom of coils).	Blower motor (2 oil cups) IBM No. 6. Apply Lubriplate No. 70 on hydraulic drive belt.
6 - 8 Line Drive	24 weeks 1200 - 1800 hrs.	Check 6-8 line detent retaining collars for loose set screws.	Apply light film Lub. No. 70 on active surfaces of all gears, shift fork, camming plate, and detent wheels, Apply IBM No. 6 on the detent arm pivots.

1405 PM ROUTINE

UNIT	FREQUENCY	PROCEDURE	CLEAN AND LUBRICATE
Access Mechanism	4 weeks 200 - 300 hrs.	Check for loose or deformed head-retaining springs. Check pinion for freedom of vertical movement on shaft. With pinion disengaged check for freedom of lateral movement of clutch on shaft. Check clutch brushes and commutator.	Clean Read/Write Heads. Replace worn tubing. Add drop of No. 6 oil to clutch shaft bearings.
Blowers and Filters	8 weeks 400 - 600 hrs.	Check all muffin fans for rotation. Replace filters if dirt is visible from inside.	
Compressor and Air System	8 weeks 400 - 600 hrs.	Check air pressure for 70 to 90 Psig. Drain moisture from drain pan. Drain moisture from receiver tank (in file) and check filter element.	Check oil level and fill with SHELL HYDRAUL No. 33, IBM PN. 2 127 714 = 0, 5 l, IBM PN. 451 012 = 1, 0 l.
Access Mechanism	12 weeks 600 - 900 hrs.	Check for free movement of carriage and access arm. Note any wear in disk detent linkage. Inspect disk and track detent switches for loose or burned contacts. Check track detent switch adjustments. Check access cable tension.	Lubricate access mechanism sparingly with IBM No. 6 on V surface of way, access arm sliding surfaces, carriage felt wipers, disk and track detents, Lubricate pinion shaft with IBM P/N 357 830 (MOLYKOTE).
Electronic Servo	12 weeks 600 - 900 hrs.	Subsequently, check DC voltages, disk and track null systems and clutch balance. Adjust dampening for smooth servo and proper access time.	
Compressor and Air System	12 weeks 600 - 900	Check air pressure at file for 55 + 1, -2 psig.	

Compressor and Air System	24 weeks 1200 - 1800 hrs.	Check filter elements in air inlet discharge bowl.	Every 1000 hrs drain and refill crank case with SHELL HYDRAUL No. 33.
Disk Array	24 weeks 1200 - 1800 hrs.	Check run down time. If too short shaft-motor should be replaced (see Ref. Man. page 30).	
Line Cord	24 weeks 1200 - 1800 hrs.	Check for safe condition and proper grounding.	

1407 PM ROUTINE

UNIT	FREQUENCY	PROCEDURE	CLEAN AND LUBRICATE
Typewriter	4 weeks 200 - 300 hrs.	Clean and check for proper operation.	Follow periodic maintenance procedure for the typewriter as described in the Typewriter CE Reference Manual F/N 223-6652. Frequency may be varied according to machine usage.
Marginal Test	12 weeks 600 - 900 hrs.	Run diagnostic test C 8004 or C 8002. Correct all troubles indicated by the test.	
	24 weeks 1200 - 1800 hrs.	Run diagnostic test C 8001 or C 8002 with $\pm 2, 0V$ variation of the +6M and -12M voltage. Correct all troubles indicated by the test.	
Misc.	24 weeks 1200 - 1800 hrs.	Check forms switch for proper operation. Check that the typeout rate is a nominal 10 characters per second.	
Filter	as required	Replace filter if dirt is visible from the inside.	
Blower	every maint. call	Check fan for rotation.	

729 PM ROUTINE

UNIT	FREQUENCY	PROCEDURE	CLEAN AND LUBRICATE
Prolays	4 weeks 200 - 300 hrs.	Scope start-stop time and wave form. Replace worn parts. Note: Frequency of prolays maintenance should be determined by IRG test and customer performance. The IRG test should be run when the machine is "warm".	Lubricate armature and arm pivots with IBM No. 6. Aeroshell No. 14 has been discontinued and will no longer be available. Lubricate idler pivot shaft with IBM No. 4.
Read Pre-amplifiers	12 weeks 600 - 900 hrs.	Check amplifier for minimum output of 10 V pp. Using the standard level tape P/N 461 108 adjust to: 8, 8 V for Mod. II or IV, 10, 0 V for Mod. V or VI. Check for electrical noise on read bus.	
Blowers and Filters	12 weeks 600 - 900 hrs.	Replace filters if dirt is visible from inside. Check blowers for proper operation.	Clean clogged blowers.
Tape Transp. Clutches	12 weeks 600 - 900 hrs.	Move tape continuously from CE Panel. Check tape movement in vacuum columns. Sluggish operation may indicate powder leakage from magnetic clutches. Check visually for powder leakage. Check contact rings and brushes for wear and arcing.	Note: Tape transport should be cleaned at least every 8 hours of operation.
Tape Break HS Rewind	12 weeks 600 - 900 hrs.	Check tape break circuit. Check for 200 - 250 gr drag on right clutch in high speed rewind status.	

Capstan Motors	12 weeks 600 - 900 hrs.	If tension is increased, check HS rewind motor for stalling when 1 inch of tape is on machine reel. Check capstan motors and high speed rewind idlers for binds. Check capstan motor front bearings for play.	Oil capstan shaft and motor bearings with IBM No. 6.
Capstan Switches	12 weeks 600 - 900 hrs.	Check for proper operation.	
Vacuum Switches	12 weeks 600 - 900 hrs.	Check for broken or cracked straps and pitted points. Replace defective capacitors.	
Tape Cleaner Blade	12 weeks 600 - 900 hrs.	Check for damage.	
H-Shield	12 weeks 600 - 900 hrs.	Check for binds or cocking and correct position. Check write feed through: With no tape movement (disconn. capstan motors) write bits in all tracks. At the read bus there must be less than 0,4 V pp.	
Erase Head	12 weeks 600 - 900 hrs.	Check position and polarity. Less than 0,4 V pp should remain after erase.	
Skew	12 weeks 600 - 900 hrs.	Check skew. Adjust if any track is out by more than 0,25 micro seconds. Use master skew tape	Lubricate the upper and lower pads in the head raising linkage with IBM No. 6. Grease the gear

		P/N 461 096 (556 BPD) or P/N 461 197 (800 BPD). Check if segment stop spring P/N 528 221 is broken. Replace by two springs.	with IBM No. 24.																										
Asymmetry 729 V and VI only	12 weeks 600 - 900 hrs.	Check for coincidence of output from skew register A in TAU while writing 1's.																											
Power Supply	24 weeks 1200 - 1800 hrs.	Check voltage level:																											
		<table border="1"> <thead> <tr> <th>Voltage</th> <th>Ripple</th> </tr> </thead> <tbody> <tr> <td>$-6 \pm 0, 24$</td> <td>0,48 V</td> </tr> <tr> <td>$+6 \pm 0, 24$</td> <td>0,48 V</td> </tr> <tr> <td>$-7, 5 \pm 0, 75$</td> <td>3,30 V</td> </tr> <tr> <td>$-12 \pm 0, 48$</td> <td>0,96 V</td> </tr> <tr> <td>$+12 \pm 0, 48$</td> <td>0,96 V</td> </tr> </tbody> </table>	Voltage	Ripple	$-6 \pm 0, 24$	0,48 V	$+6 \pm 0, 24$	0,48 V	$-7, 5 \pm 0, 75$	3,30 V	$-12 \pm 0, 48$	0,96 V	$+12 \pm 0, 48$	0,96 V	<table border="1"> <thead> <tr> <th>NOR</th> <th>Relay</th> </tr> </thead> <tbody> <tr> <td>test point</td> <td>test point</td> </tr> <tr> <td>A3 K01M</td> <td>F 13 K</td> </tr> <tr> <td>A3 K01H</td> <td>F 31 L</td> </tr> <tr> <td>A3 K01P</td> <td>PW transist. panel 6-9</td> </tr> <tr> <td>A3 K01G</td> <td>F 31 M</td> </tr> <tr> <td>A3 K01A</td> <td>F 31 Q</td> </tr> </tbody> </table>	NOR	Relay	test point	test point	A3 K01M	F 13 K	A3 K01H	F 31 L	A3 K01P	PW transist. panel 6-9	A3 K01G	F 31 M	A3 K01A	F 31 Q
Voltage	Ripple																												
$-6 \pm 0, 24$	0,48 V																												
$+6 \pm 0, 24$	0,48 V																												
$-7, 5 \pm 0, 75$	3,30 V																												
$-12 \pm 0, 48$	0,96 V																												
$+12 \pm 0, 48$	0,96 V																												
NOR	Relay																												
test point	test point																												
A3 K01M	F 13 K																												
A3 K01H	F 31 L																												
A3 K01P	PW transist. panel 6-9																												
A3 K01G	F 31 M																												
A3 K01A	F 31 Q																												
		Move potentiometers in the power supplies to minimum and maximum position to detect creeping resistance in the potentiometer.																											
		Check voltage across load point and tape indicate bulb (with tape in columns it should be $6, 3 \pm 0, 2V$), across tape break lamp it should be 8,5V. Check voltage for high speed rewind lamp on A3 D10D (it should be $6, 0 \pm 0, 2V$).																											

7330 PM ROUTINE

UNIT	FREQUENCY	PROCEDURE	CLEAN AND LUBRICATE
Capstan Motor	4 weeks 200 - 300 hrs.	Check for binds in motor shaft.	Lubricate capstan drive motor with IBM No. 6.
Reel Brakes	4 weeks 200 - 300 hrs.	Check for proper clearance between armature and fixed part of brake.	Clean brakes without fluid.
Read Pre-amplifier	12 weeks 600 - 900 hrs.	Check for minimum amplitude of 10V pp when amplifiers are operated at maximum gain. Adjust for 8,8V output using standard level tape P/N 461 108.	
Skew	12 weeks 600 - 900 hrs.	Check skew adjust if any track is out by more than $3, 0 \mu\text{sec}$. Use master skew tape P/N 461 096.	
Tape Transport 1	12 weeks 600 - 900 hrs.	Check rocker arm linkage for binds, also check start-stop timings. Observe tape for proper tracking.	
Belts	24 weeks 1200 - 1800 hrs.	Check for wear and proper tension of reel belts.	
Capstan Belts	24 weeks 1200 - 1800 hrs.	Check capstan belts for wear and proper tension.	Clean capstan drive belts.

Blowers and Filters	24 weeks 1200 - 1800 hrs.	Replace filters if dirt is visible from inside. Check blowers for proper operation.
Single Shots	24 weeks 1200 - 1800 hrs.	Observe output of every single shot for proper timing duration.
Power Supply	48 weeks 2400 - 3600 hrs.	Check voltage and AC ripple. Check vacuum motor carbon brushes.

1403

TYPE ARRANGEMENT IDENTIFICATION

IBM 1403

IBM WORLD TRADE CORPORATION

TYPE ARRANGEMENT IDENTIFICATION

AUGUST 63 EDITION

(STANDARD ARRANGEMENTS ONLY)

A single array is shown - blank blocks indicate character is same as "A" arrangement

Styles A - K are .093" (2,35 mm) high and have a flat top "3"

x Styles A2 - K2 are .093" (2,35mm) high and have a round top "3"

+ Styles A3 - K3 are .079" (2,0 mm) high

o Style A4 Special character style which can be read in IBM 1428

NOTE: Character height is measured from outside edge (Example I $\frac{+}{-}$)

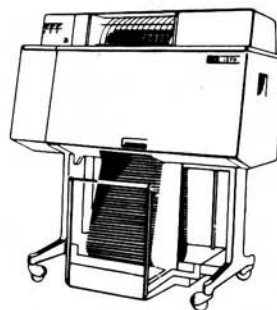

USA

STANDARD * x + o
A, A2, A3, A4

S £
S O
S £ > #
- =
- +
I =
@ =

WV	UT	S/	@#	09	87	65	43	21	□	£	HG	FE	DC	BA	* \$	-R	QP	ON	ML	KJ	%	#	Z	YX	
		S £								/ I															
		S O								- I															
		S £	> #						<	- I					* *	/ R									
		- =)	+ I													(,	
		- +)	+ I														(,
		I =)	+ I														(,
		@ =)	+ I														(,

CHAIN & CARTRIDGE
PART NUMBERS
STANDARD

TYPE ARRANGEMENT	CHAIN PART NO.	STD. CARTRIDGE PART NO.	INTERCHANGEABLE CART. PART NO.	TYPE ARRANGEMENT	CHAIN PART NO.	STD. CARTRIDGE PART NO.	INTERCHANGEABLE CART. PART NO.
A	474245	474183	475356	G2	475236	475246	475372
B	474246	474184	475357	H2	475237	475247	475373
C	474247	474185	475358	J2	475238	475248	475374
D	474248	474186	475359	K2	475239	475249	475375
E	474249	474187	475360				
F	474250	474188	475361	A3	475591	475601	475611
G	474251	474189	475362	B3	475592	475602	475612
H	474252	474190	475363	C3	475593	475603	475613
J	474253	474225	475364	D3	475594	475604	475614
K	474244	474135	475365	E3	475595	475605	475615
Above arrangements will be available by RSDP only				F3	475596	475606	475616
A2	475230	475240	475366	G3	475597	475607	475617
B2	475231	475241	475367	H3	475598	475608	475618
C2	475232	475242	475368	J3	475599	475609	475619
D2	475233	475243	475369	K3	475600	475610	475620
E2	475234	475244	475370	A4	730066	730067	730068
F2	475235	475245	475371	Numeric .093"	475310	None	475332
				Numeric .079"	475689	None	475890

AUSTRIA

WORLD TRADE DEVIATIONS

STANDARD * x +
A, A2, A3
AUSTRIA A2

WV	UT	S/	@#	09	87	65	43	21	II.	LI	HG	FE	DC	BA	* \$	-R	QP	ON	ML	KJ	%	‡ Z	YX
															* S								

CHAIN & CARTRIDGE
PART NUMBERS
AUSTRIA

TYPE ARRANGEMENT	CHAIN PART NO.	STD. CARTRIDGE PART NO.	INTERCHANGEABLE CART. PART NO.	TYPE ARRANGEMENT	CHAIN PART NO.	STD. CARTRIDGE PART NO.	INTERCHANGEABLE CART. PART NO.
A 2	4063926	4063927	4066527	numeric .093"	4063881	none	4063882

BELGIUM

STANDARD * x +
A A2 A3
BELGIUM A A2
G2
H2
J2
K K2

WV	UT	S/	@#	09	87	65	43	21	II.	LI	HG	FE	DC	BA	* \$	-R	QP	ON	ML	KJ	%	‡ Z	YX
										& I					* Fr								
			- +							+ I					* Fr								
			† =) . + I					* Fr						(,		
										+ I					* Fr								
			@ =) . + I					* Fr						(,		

CHAIN & CARTRIDGE
PART NUMBERS
BELGIUM

TYPE ARRANGEMENT	CHAIN PART NO.	STD. CARTRIDGE PART NO.	INTERCHANGEABLE CART. PART NO.	TYPE ARRANGEMENT	CHAIN PART NO.	STD. CARTRIDGE PART NO.	INTERCHANGEABLE CART. PART NO.
A	4063628	4063629	none	J2	4063859	4063860	none
A2	4063630	4063631	4066593	K	4063698	4063699	none
G2	4063640	4063641	none	K2	4063691	4063692	none
H2	4063867	4063868	none	numeric .093"	4066594	none	4066595

DENMARK

STANDARD * x +
A A2 A3
DENMARK A A2
B B2
C C2

WV	UT	S/	@#	09	87	65	43	21	II.	LI	HG	FE	DC	BA	* \$	-R	QP	ON	ML	KJ	%	‡ Z	YX
		S A	/ &					21	U .	X B					* K								Y/E
		S X						21	U .	X B					* A								Y/E
			β Æ						U .	& I					* A								

CHAIN & CARTRIDGE
PART NUMBERS
DENMARK

TYPE ARRANGEMENT	CHAIN PART NO.	STD. CARTRIDGE PART NO.	INTERCHANGEABLE CART. PART NO.	TYPE ARRANGEMENT	CHAIN PART NO.	STD. CARTRIDGE PART NO.	INTERCHANGEABLE CART. PART NO.
A	754279	754280	756535	B2	757891	757892	4063769
A2	757889	757890	none	C	754287	754288	756537
B	754284	754285	756536	C2	757893	757894	4063754

FRANCE

STANDARD * x +
A A2 A3
FRANCE A
A2
F F2
H H2 H3
J J2
K K2

WV	UT	S/	@#	09	87	65	43	21	II.	LI	HG	FE	DC	BA	* \$	-R	QP	ON	ML	KJ	%	‡ Z	YX
										& I					*								
			- =) . + I					*						(,		
			† =) . + I					*						(,		
										+ I					*								
			@ =) . + I					*						(,		

CHAIN & CARTRIDGE
PART NUMBERS
FRANCE

TYPE ARRANGEMENT	CHAIN PART NO.	STD. CARTRIDGE PART NO.	INTERCHANGEABLE CART. PART NO.	TYPE ARRANGEMENT	CHAIN PART NO.	STD. CARTRIDGE PART NO.	INTERCHANGEABLE CART. PART NO.
- A	750811	750812	756473	H3	4066529	4066530	none
A2	758329	758330	4063763	J	4063786	4063787	none
F	4063453	4063454	none	J2	4063800	4063801	none
F2	4066575	4066576	4066968	K	4063490	4063491	4063779
H	4063468	4063469	4063625	K2	4063997	4063998	none
H2	4063872	4063873	4063878	numeric .093"	4063737	none	4063738

GERMANY

STANDARD A A2 A3
GERMANY A A2

W	V	U	T	S/	@#	09	87	65	43	21	Π.	£I	HG	FE	DC	BA	*\$	-R	QP	ON	ML	KJ	%	‡Z	YX
				S'								·I													

CHAIN & CARTRIDGE
PART NUMBERS
GERMANY

TYPE ARRANGEMENT	CHAIN PART NO.	STD. CARTRIDGE PART NO.	INTERCHANGEABLE CART. PART NO.	TYPE ARRANGEMENT	CHAIN PART NO.	STD. CARTRIDGE PART NO.	INTERCHANGEABLE CART. PART NO.
A	750808	750809	756472	numeric .093"	4063792	none	4063793
A2	758331	758332	4063762				

GREECE

STANDARD A A2 A3
GREECE A A2
B

W	V	U	T	S/	@#	09	87	65	43	21	Π.	£I	HG	FE	DC	BA	*\$	-R	QP	ON	ML	KJ	%	‡Z	YX
Φ	Υ	Τ	&	Σ	£	-@					Α	·	+I	Θ	H	Z	E	Δ	Γ						
Φ	Υ	Τ	=	Σ/							£	·	&I	Θ	H	Z	E	Δ	Γ						

CHAIN & CARTRIDGE
PART NUMBERS
GREECE

TYPE ARRANGEMENT	CHAIN PART NO.	STD. CARTRIDGE PART NO.	INTERCHANGEABLE CART. PART NO.	TYPE ARRANGEMENT	CHAIN PART NO.	STD. CARTRIDGE PART NO.	INTERCHANGEABLE CART. PART NO.
A	4063549	4063550	4063797	B	4066975	none	4066976
A2	758664	758665	none				

ICELAND

STANDARD A A2 A3
ICELAND A2

W	V	U	T	S/	@#	09	87	65	43	21	Π.	£I	HG	FE	DC	BA	*\$	-R	QP	ON	ML	KJ	%	‡Z	YX	
				S	Ö	Æ					·	·	·					·	·						Þ	Ú

CHAIN & CARTRIDGE
PART NUMBERS
ICELAND

TYPE ARRANGEMENT	CHAIN PART NO.	STD. CARTRIDGE PART NO.	INTERCHANGEABLE CART. PART NO.	TYPE ARRANGEMENT	CHAIN PART NO.	STD. CARTRIDGE PART NO.	INTERCHANGEABLE CART. PART NO.
A2	859922	859923	none				

IRAN

CHAIN & CARTRIDGE
PART NUMBERS
IRAN

TYPE ARRANGEMENT	CHAIN PART NO.	STD. CARTRIDGE PART NO.	INTERCHANGEABLE CART. PART NO.	TYPE ARRANGEMENT	CHAIN PART NO.	STD. CARTRIDGE PART NO.	INTERCHANGEABLE CART. PART NO.
numeric .093"	758054	none	758055				

ISRAEL

STANDARD A A2 A3
ISRAEL B (A2)

W	V	U	T	S/	@#	09	87	65	43	21	Π.	£I	HG	FE	DC	BA	*\$	-R	QP	ON	ML	KJ	%	‡Z	YX
פ	צ	ץ	ך	/	"	#					·	·	·	·	·	·	·	·	·	·	·	·	·	·	·

CHAIN & CARTRIDGE
PART NUMBERS
ISRAEL

TYPE ARRANGEMENT	CHAIN PART NO.	STD. CARTRIDGE PART NO.	INTERCHANGEABLE CART. PART NO.	TYPE ARRANGEMENT	CHAIN PART NO.	STD. CARTRIDGE PART NO.	INTERCHANGEABLE CART. PART NO.
B (A2)	756522	756523	4063761				

ITALY

STANDARD * x +
 ITALY A A2 A3
 H2
 J J2

WV	UT	S/	@ #	09	87	65	43	21	II.	& I	HG	FE	DC	BA	* \$	-R	QP	ON	ML	KJ	%	‡ Z	YX
			@ =)	+ I					* f							(
										+ I					* f								

CHAIN & CARTRIDGE
PART NUMBERS

ITALY

TYPE ARRANGEMENT	CHAIN PART NO.	STD. CARTRIDGE PART NO.	INTERCHANGEABLE CART. PART NO.	TYPE ARRANGEMENT	CHAIN PART NO.	STD. CARTRIDGE PART NO.	INTERCHANGEABLE CART. PART NO.
A	4063668	4063669	4063766	J	4063759	4063760	none
A2	4063721	4063722	none	J2	4063764	4063908	4063765
A3	4209370	4209371	none				
H2	4063995	4063996	none	numeric .093"	4063739	none	4063740

JAPAN

STANDARD * x +
 JAPAN A A2 A3
 K2
 J2

WV	UT	S/	@ #	09	87	65	43	21	II.	& I	HG	FE	DC	BA	* \$	-R	QP	ON	ML	KJ	%	‡ Z	YX
			@ =)	+ I					* y							(
										+ I					* y								

CHAIN & CARTRIDGE
PART NUMBERS

JAPAN

TYPE ARRANGEMENT	CHAIN PART NO.	STD. CARTRIDGE PART NO.	INTERCHANGEABLE CART. PART NO.	TYPE ARRANGEMENT	CHAIN PART NO.	STD. CARTRIDGE PART NO.	INTERCHANGEABLE CART. PART NO.
A	753448	753449	756532	K2	4063727	4063728	none
A2	755682	755683	756533	J2	4209348	4209349	none

NETHERLANDS

STANDARD * x +
 NETHER- A A2 A3
 LANDS K

WV	UT	S/	@ #	09	87	65	43	21	II.	& I	HG	FE	DC	BA	* \$	-R	QP	ON	ML	KJ	%	‡ Z	YX
			@ =)	+ I					* f							(
										+ I					* f								

CHAIN & CARTRIDGE
PART NUMBERS

NETHERLANDS

TYPE ARRANGEMENT	CHAIN PART NO.	STD. CARTRIDGE PART NO.	INTERCHANGEABLE CART. PART NO.	TYPE ARRANGEMENT	CHAIN PART NO.	STD. CARTRIDGE PART NO.	INTERCHANGEABLE CART. PART NO.
A	4063497	4063498	none	K	4063619	4363620	none
A2	4063656	4063657	none				
A3	4066586	4066587	none				

NORWAY

STANDARD * x +
 NORWAY A A2 A3
 B B2
 C C2

WV	UT	S/	@ #	09	87	65	43	21	II.	& I	HG	FE	DC	BA	* \$	-R	QP	ON	ML	KJ	%	‡ Z	YX
YX	WV	UO	X β					ZI		/ J					* &	-T	SR	QP	NM	LK		# β	Æ Å
			β Æ					U.		& I					* A								

CHAIN & CARTRIDGE
PART NUMBERS

NORWAY

TYPE ARRANGEMENT	CHAIN PART NO.	STD. CARTRIDGE PART NO.	INTERCHANGEABLE CART. PART NO.	TYPE ARRANGEMENT	CHAIN PART NO.	STD. CARTRIDGE PART NO.	INTERCHANGEABLE CART. PART NO.
A	750853	750854	756527	B2	758620	758621	none
A2	758618	758619	none	C	754287	754288	756537
B	750859	750860	756528	C2	757893	757894	4063754

PORTUGAL

STANDARD * x +
 PORTUGAL A2 A3

WV	UT	S/	@ #	09	87	65	43	21	II.	& I	HG	FE	DC	BA	* \$	-R	QP	ON	ML	KJ	%	‡ Z	YX
			⊙ A					*	⊙						*								

CHAIN & CARTRIDGE
PART NUMBERS

PORTUGAL

TYPE ARRANGEMENT	CHAIN PART NO.	STD. CARTRIDGE PART NO.	INTERCHANGEABLE CART. PART NO.	TYPE ARRANGEMENT	CHAIN PART NO.	STD. CARTRIDGE PART NO.	INTERCHANGEABLE CART. PART NO.
A2	758059	758060	none				

PUERTO RICO

STANDARD * x +
 A A2 A3
 PUERTO A A2 A3
 RICO H2
 K2

WV	UT	S/	@#	09	87	65	43	21	II.	&I	HG	FE	DC	BA	*\$	-R	QP	ON	ML	KJ	%	↑Z	YX
										NI													
										NI													
										NI													

CHAIN & CARTRIDGE
 PART NUMBERS

PUERTO RICO

TYPE ARRANGEMENT	CHAIN PART NO.	STD. CARTRIDGE PART NO.	INTERCHANGEABLE CART. PART NO.	TYPE ARRANGEMENT	CHAIN PART NO.	STD. CARTRIDGE PART NO.	INTERCHANGEABLE CART. PART NO.
A	750803	750804	756471	H2	4066501	4066502	
A2	758327	758328	4066505	K2	4066506	4066506	none
A3	4066503	4066988	4066504				4066507

SOUTH AFRICA

STANDARD * x +
 A A2 A3
 SOUTH A A2
 AFRICA C C2
 H2

WV	UT	S/	@#	09	87	65	43	21	II.	&I	HG	FE	DC	BA	*\$	-R	QP	ON	ML	KJ	%	↑Z	YX

CHAIN & CARTRIDGE
 PART NUMBERS

SOUTH AFRICA

TYPE ARRANGEMENT	CHAIN PART NO.	STD. CARTRIDGE PART NO.	INTERCHANGEABLE CART. PART NO.	TYPE ARRANGEMENT	CHAIN PART NO.	STD. CARTRIDGE PART NO.	INTERCHANGEABLE CART. PART NO.
A	4063650	4063651	none	C2	4063944	4063945	none
A2	4063874	4063875	4063901	H2	4209362	4209363	none
C	4063719	4063720	none	numeric	4063899	none	4063900

SPAIN

STANDARD * x +
 A A2 A3
 SPAIN A A2
 J2

WV	UT	S/	@#	09	87	65	43	21	II.	&I	HG	FE	DC	BA	*\$	-R	QP	ON	ML	KJ	%	↑Z	YX

CHAIN & CARTRIDGE
 PART NUMBERS

SPAIN

TYPE ARRANGEMENT	CHAIN PART NO.	STD. CARTRIDGE PART NO.	INTERCHANGEABLE CART. PART NO.	TYPE ARRANGEMENT	CHAIN PART NO.	STD. CARTRIDGE PART NO.	INTERCHANGEABLE CART. PART NO.
A	4063666	4063667	4063776	J2	4063784	4063794	4063785
A2	4063735	4063736	4063869	numeric .093"	4063777	none	4063778

SWEDEN/FINLAND

STANDARD * x +
 A A2 A3
 SCHWEDENA A2
 FINLAND B B2
 F F2

WV	UT	S/	@#	09	87	65	43	21	II.	&I	HG	FE	DC	BA	*\$	-R	QP	ON	ML	KJ	%	↑Z	YX

CHAIN & CARTRIDGE
 PART NUMBERS

SCHWEDEN
 FINLAND

TYPE ARRANGEMENT	CHAIN PART NO.	STD. CARTRIDGE PART NO.	INTERCHANGEABLE CART. PART NO.	TYPE ARRANGEMENT	CHAIN PART NO.	STD. CARTRIDGE PART NO.	INTERCHANGEABLE CART. PART NO.
A	750838	750839	756474	B2	757897	757898	758063
A2	757895	757896	758075	F	752844	752845	756526
B	750843	750844	756525	F2	757945	757946	758077

SWITZERLAND

STANDARD * x +
 A A2 A3
 SWITZER- A A2
 LAND D
 F

W	V	U	T	S/	@ #	0	9	8	7	6	5	4	3	2	1	II	.	& I	H	G	F	E	D	C	B	A	* \$	- R	Q	P	O	N	M	L	K	J	%	,	‡	Z	Y	X												
																												* Fr																										
																												* Fr																										
																												* Fr																										

CHAIN & CARTRIDGE
 PART NUMBERS

SWITZERLAND

TYPE ARRANGEMENT	CHAIN PART NO.	STD. CARTRIDGE PART NO.	INTERCHANGEABLE CART. PART NO.	TYPE ARRANGEMENT	CHAIN PART NO.	STD. CARTRIDGE PART NO.	INTERCHANGEABLE CART. PART NO.
A	4063431	4063432	none	D	4063614	4063615	none
A2	4063482	4063483	4063751	F	4063433	4063434	none

TURKEY

STANDARD * x +
 A A2 A3
 TURKEY A A2

W	V	U	T	S/	@ #	0	9	8	7	6	5	4	3	2	1	II	.	& I	H	G	F	E	D	C	B	A	* \$	- R	Q	P	O	N	M	L	K	J	%	,	‡	Z	Y	X								
M	L	K	J	I	H																						* π	- Z	Y	V	U	U	T	S	S	R														

CHAIN & CARTRIDGE
 PART NUMBERS

TURKEY

TYPE ARRANGEMENT	CHAIN PART NO.	STD. CARTRIDGE PART NO.	INTERCHANGEABLE CART. PART NO.	TYPE ARRANGEMENT	CHAIN PART NO.	STD. CARTRIDGE PART NO.	INTERCHANGEABLE CART. PART NO.
A	4063585	4063586	none	A2	859918	859919	none

UNITED KINGDOM (STERLING)

STANDARD * x +
 A A2 A3
 UNITED A A2 A3
 KINGDOM A3^{x)} A3⁺
 (STERLING) B
 F
 H
 H3^{x)} H3⁺
 J2
 K K2

W	V	U	T	S/	@ #	0	9	8	7	6	5	4	3	2	1	II	.	& I	H	G	F	E	D	C	B	A	* \$	- R	Q	P	O	N	M	L	K	J	%	,	‡	Z	Y	X													
																												* £																											
																												* £																											
				S &																								* £																											
					- =																							* £																											
					! =																							* £																											
					& =																							* £																											
																												* £																											
					@ =																							* £																											

x) A and/or H style

+) A2 and/or H2 style

CHAIN & CARTRIDGE
 PART NUMBERS

UNITED KINGDOM
 (STERLING)

TYPE ARRANGEMENT	CHAIN PART NO.	STD. CARTRIDGE PART NO.	INTERCHANGEABLE CART. PART NO.	TYPE ARRANGEMENT	CHAIN PART NO.	STD. CARTRIDGE PART NO.	INTERCHANGEABLE CART. PART NO.
A	750514	750515	756470	F	4063706	4063707	none
A2	4063484	4063485	none	H	4063623	4063624	none
A3	4209352	4209353	none	H3 (H)	4063532	4063533	none
A3 (A)	4063529	4063530	none	H3 (H2)	758325	758326	none
A3 (A2)	757947	757948	none	I2	4066537	4066538	none
B	4063448	4063449	none	K	4063499	4063500	none
				K2	4209374	4209375	none
				numeric .093"	4066517	none	4066518

FIELD REPLACEMENT CARDS

SMS Field Replacement Cards "most used" for 1401 System.

A group of pluggable CAP CARD Assemblies has been provided for field replacement of SMS Cards with the fixed factory programmed cap. For the 1401 System the following "most used" Field Replacement Cards are important for your service.

With Field Replacement Card the following SMS Cards may be replaced

P/N	Description	P/N
370975	371251 OSM	371072 OXC
	371261 OSM	371254 ORW
	371262 OSM	371269 ORV
	371263 O---	371270 ORP
370976	371252 OSM	371073 OLVF
	371264 ORW	371074 OLVS
	371265 ORV	371075 OLVH
	371266 O---	371255 OLVQ
370977	371071 OJYC	371274 ORZV
	371253 OLVW	371275 ORZT
	371267 OLVU	371276 OR--
	371268 OLVF	371277 ORTO
370978	371072 OXC	371271 OQZV
	371254 ORW	371272 OQZT
	371269 ORV	371273 OQ--
	371270 ORP	371278 OQTO
370979	371073 OLVF	371580 JOHM
	371074 OLVS	371581 JOVM
	371075 OLVH	371582 JOVV
	371255 OLVQ	371583 JO--
370980	371274 ORZV	
	371275 ORZT	
	371276 OR--	
	371277 ORTO	
370981	371271 OQZV	
	371272 OQZT	
	371273 OQ--	
	371278 OQTO	
370983	371580 JOHM	
	371581 JOVM	
	371582 JOVV	
	371583 JO--	

For further information see 1401 CEM 29 (77) and the instructions given in the Cap Instructions, which must be available at every installation. (The cap kit B/M 8.021.500 must be ordered by your local BO from your Paris Distribution Center, e.g. within Germany from Zentrallager Frankfurt).

YUGOSLAVIA

STANDARD * * * +
 JUGOS- A A2 A3
 LAVIA

CHAIN & CARTRIDGE
 PART NUMBERS

JUGOSLAVIA

TYPE ARRANGEMENT	CHAIN PART NO.	STD. CARTRIDGE PART NO.	INTERCHANGEABLE CART. PART NO.	TYPE ARRANGEMENT	CHAIN PART NO.	STD. CARTRIDGE PART NO.	INTERCHANGEABLE CART. PART NO.
A	758019	758020	none	A2	859920	859921	none

WV	UT	S/	@ #	09	87	65	43	21	H	£1	HG	FE	DC	BA	* \$	-R	QP	ON	ML	KJ	%	‡Z	YX
UT	SS	R/	* Ø						Ø	+G	FE	DČ	ČC		* D	-P	ON	ML	KJ	IH		‡Z	ZV

COMPONENT CIRCUITS REFERENCE

ALD BLOCK

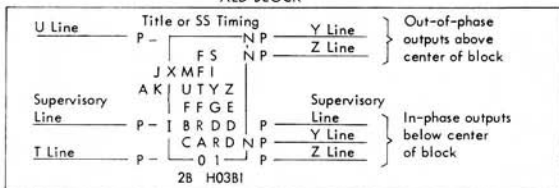

- FS - Functional symbol (up to four characters -A, -TO, SS, ---)
 MFI - Machine feature index or special note (up to four characters)
 UT - Line type in
 YZ - Line type out
 FF - Frame (01 - 99)
 G - Sliding gate (A, B, C, D) or module (A, B, C, ---)
 E - Engineering change level (A, B, C, ---)
 B - Chassis (1 - 6) or swinging gate (1 - 8)
 R - Chassis Row (A - K) or swinging gate column (A - F)
 DD - Chassis column (01 - 28) or swinging gate row (01 - 26)
 P - Card socket pin (single card: A-R; double, Stan-Pac, or twin: A-8)
 JX - Shield lead connected to pin J (X = twisted pair; * = coaxial cable)
 AK - Pin A backpanel wired to pin K
 CARD - Card code
 2B - Page coordinates
 H03BI - For engineering use; block identification (circuit type)
 01 - For engineering use; block configuration (01, 02, 03, ---)
 N - When used means normal (not supervisory) output, load in this block.
 I - One of six symbols:
 3 - Third level input, load in this block
 ◊ - Third level input, load elsewhere
 S - Split level input, load in this block
 2 - Split level input, load elsewhere
 C - Cascode level input, load in this block
 H - Cascode level input, load elsewhere

LINE LEVELS

Line Type	Ideal Swing (volts)	Down Levels (volts)		Up Levels (volts)		Application
		Low	High	Low	High	
B	0 to +6	+0.1	+0.3	+2.7	+6.8	DDTL, Uncompensated
B	0 to +6	+0.1	+0.3	+5.6	+6.8	DDTL, Compensated
B	0 to +6	-0.8	+0.8	+3.2	+6.8	DDTL, DE Chain
C	0 to 15 ma	-4.1	-0.3	+0.6	+3.1	Std Interface DL, DT
D	-2.5 to +2.5	-5.0	-0.7	+0.7	+5.0	DEFL
E	-6 to +6	-25.0	-3.0	+3.0	+25.0	EIA Std Data Sets
N	± from 0 ref	-3.0	-0.4	+0.4	+1.2	Alloy Current Sw
N	± from 0 ref	-0.9	-0.4	+0.4	+0.6	Diffused Current Sw
P	± from -6 ref	-7.2	-6.4	-5.6	-3.0	Alloy Current Sw
P	± from -6 ref	-6.6	-6.4	-5.6	-5.2	Diffused Current Sw
Q	0 to 40 ma	-3.8	-0.5*	+0.6	+2.4	DL and DT
R	0 to +12	-0.4	+0.2	+5.6	+12.5	CTRL
S	-12 to 0	-12.5	-5.6	-0.2	+0.4	CTRL
S	-12 to 0	-12.5	-6.9	-0.5	0.0	SDTRL
S†	-6 to 0	-6.9	-5.9	-0.5	0.0	Clamped SDDTL
T	-6 to +6	-6.2	-0.7	+1.4	+6.2	CTDL
U	-12 to 0	-12.5	-7.4	-5.3	+0.2	CTDL
V	Any					Special
W	# 0 to -48	-53.0	-43.0	-2.0	0.0	Relays
X	-30 to +10	-60.0	-18.3	+5.5	+40.0	Tubes
Y	-6 to 0	-8.8	-5.8	-0.7	-0.1	SDDTL
Z	-6 to +6	-7.0	-4.2	+3.0	+6.2	Magnetic Shift Cores

* High down level can go to +0.1 on some circuits
 # 0 to relay source voltage; typically, 0 to -48

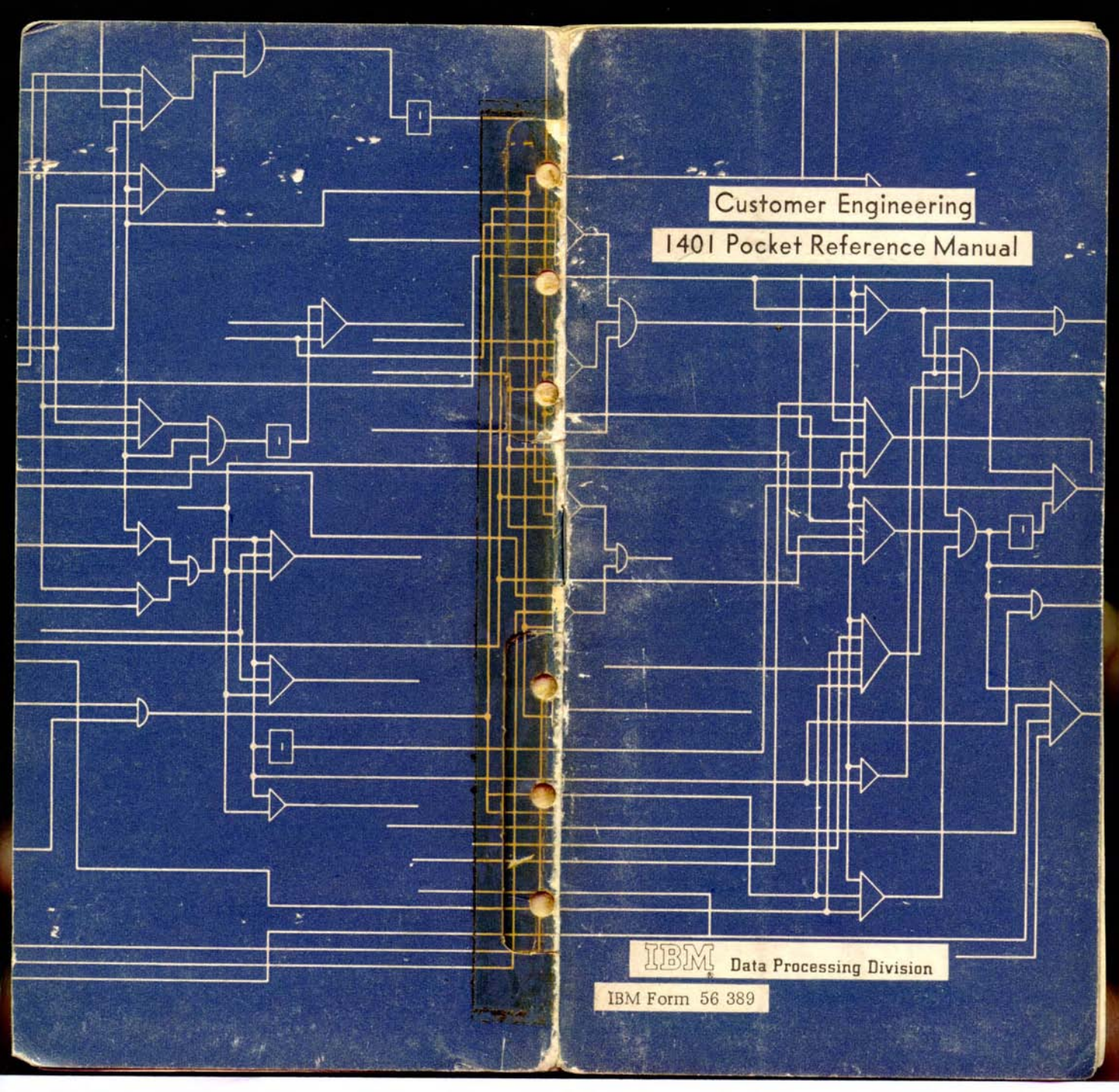

Customer Engineering
1401 Pocket Reference Manual

IBM Data Processing Division

IBM Form 56 389

